



# REHLKO *PW* 9500DPA

Modular three-phase uninterruptible power supply

(100–500 kVA/kW)

Parallelable up to 3 MVA/MW

User Manual

## Document Control

ISSUE	DATE	REVISION SUMMARY
TS_860_01	29/11/2023	Rebranding to KUP International Version
TS_860_02	11/06/2026	Rebranded to Rehlko, VRLA float voltage amended.

## Useful Contacts

### UK

[www.ups.rehlko.co.uk](http://www.ups.rehlko.co.uk)

[ukservice.ups@rehlko.com](mailto:ukservice.ups@rehlko.com)

[uktechnicalsupport.ups@rehlko.com](mailto:uktechnicalsupport.ups@rehlko.com)

[uksales.ups@rehlko.com](mailto:uksales.ups@rehlko.com)

[ukservicesales.ups@rehlko.com](mailto:ukservicesales.ups@rehlko.com)

Rehlko web site

Service department – booking service, fault reporting etc.

Technical queries

Hardware sales

Extended warranty agreements etc

### IRELAND

[www.ups.rehlko.ie](http://www.ups.rehlko.ie)

[ieinfo.ups@rehlko.com](mailto:ieinfo.ups@rehlko.com)

Rehlko web site

Service department, technical queries, hardware sales and extended warranty agreements

### SINGAPORE

[www.ups.rehlko.sg](http://www.ups.rehlko.sg)

[salesups.sg@rehlko.com](mailto:salesups.sg@rehlko.com)

[serviceups.sg@rehlko.com](mailto:serviceups.sg@rehlko.com)

Rehlko web site

Hardware sales

Contract customer support, maintenance contracts renewals

All product, product specifications and data are subject to change without notice to improve reliability, function, design or otherwise. Rehlko has taken every precaution to produce an accurate, complete and easy to understand specification document and will assume no responsibility nor liability for direct, indirect or accidental personal or material damage due to any misinterpretation of, or accidental errors, in this manual.

© 2026 Rehlko

This document may not be copied or reproduced without written permission of Rehlko.

## Contents

<b>1. Safety</b>	<b>1</b>
1.1 Description of symbols used in this manual	1
1.2 User precautions	1
1.3 Terminology	2
<b>2. General Description</b>	<b>3</b>
2.1 Introduction	3
2.2 Model range	4
2.3 UPS Module functional description	5
2.3.1 UPS Module internal operation	5
2.3.2 UPS Module operational states	6
2.3.3 UPS system operating modes summary	9
2.4 Parallel system operation	10
2.5 Xtra VFI mode	11
2.5.1 Introduction	11
2.5.2 Operation	12
2.6 Rehiko PW 9500DPA Operator controls	13
2.6.1 Power switches	13
2.7 UPS Module control panel	14
2.7.1 Module control panel buttons	14
2.7.2 Mimic LED Indication	15
2.7.3 Power Management Display (PMD)	15
2.8 System control panel	19
2.9 Customer interface board	20
2.10 Warranty	21
2.11 Extended Warranty	21
2.12 Additional Service/Maintenance Support	22
<b>3. System Control Panel</b>	<b>23</b>
3.1 Introduction	23
3.1.1 Display Header Bar	24
3.2 HOME screen	25
3.2.1 Events	25
3.2.2 Measures	26
3.2.3 Commands	27
3.2.4 UPS Data	27
3.2.5 User	27
3.3 MIMIC screen	28
3.3.1 MIMIC screen indications	29
3.3.2 Metering from the MIMIC screen	31
3.4 XTRA VFI screen(s)	32
3.5 MODULE SELECTION screen	33
<b>4. Installation</b>	<b>34</b>
4.1 Introduction	34

4.2 Taking receipt of the UPS	34
4.2.1 Reporting transportation damage	34
4.2.2 Local transportation	35
4.2.3 Storage	35
4.3 Unpacking the equipment	35
4.4 Installation planning (environmental & mechanical)	37
4.4.1 Environmental considerations	37
4.4.2 UPS cabinet installation	37
4.4.3 Battery cabinet installation	39
4.5 Planning the installation (cabling considerations)	39
4.5.1 General requirements	39
4.5.2 Parallel cabinet cabling recommendations	40
4.5.3 External maintenance bypass switch	41
4.5.4 Cable sizing	42
4.5.5 Cabling configurations	44
4.5.6 Power cable terminations	45
4.6 UPS Cabling procedure	49
4.6.1 Safety notes	49
4.6.2 Preparing the UPS power cabling	49
4.6.3 Connecting the UPS input cables	49
4.6.4 Connecting the UPS output cables	50
4.6.5 Connecting the battery cables	50
4.6.6 Multi-cabinet parallel control cabling and configuration	50
4.6.7 Module customer interface facilities	51
<b>5. Operating Instructions 1</b>	<b>52</b>
5.1 Introduction	52
5.1.1 Commissioning	52
5.1.2 Operating procedure summary	52
5.1.3 General warnings	53
5.2 Operating instructions	53
5.3 How to start the UPS system from a fully powered-down condition	53
5.4 How to start the UPS system from the maintenance bypass	55
5.5 How to transfer the load to maintenance bypass	55
5.6 How to shut down the complete UPS system	57
5.7 Operating in 'on bypass' mode	58
5.7.1 How to Turn ON the UPS in 'on bypass' mode	58
5.7.2 How to Turn OFF the UPS in 'on bypass' mode	58
5.7.3 How to transfer between 'on bypass' and 'on inverter' mode	58
<b>6. Operating Instructions 2</b>	<b>59</b>
6.1 Introduction	59
6.1.1 Commissioning	59
6.1.2 Operating procedure summary	59
6.1.3 General warnings	60
6.2 Operating instructions	60
6.3 How to start the UPS system from a fully powered-down condition	60

6.4	How to turn off the load and power-down the UPS system	62
6.5	Operating in 'on bypass' (ECO) mode	63
6.5.1	How to Turn ON the UPS in 'on bypass' mode	63
6.5.2	How to Turn OFF the UPS in 'on bypass' mode	63
6.5.3	How to transfer between 'on bypass' and 'on inverter' mode	63
<b>7.</b>	<b>Maintenance</b>	<b>65</b>
7.1	Introduction	65
7.2	Scheduled maintenance	65
7.2.1	Preventative maintenance inspection	65
7.2.2	System calibration	65
7.2.3	Battery maintenance and testing	66
<b>8.</b>	<b>Troubleshooting</b>	<b>67</b>
8.1	Fault and alarm indications	67
8.2	Fault identification and rectification	68
8.3	Contacting service	68
<b>9.</b>	<b>Options</b>	<b>69</b>
9.1	Introduction	69
9.2	Customer interface board	69
9.2.1	Serial RS-232/ USB Computer interface – JD1 & USB (Smart Port)	70
9.2.2	Dry ports customer interface (X2, X3)	70
9.2.3	RS485 Interface for multidrop – JR2	72
9.2.4	RS485 Interface for remote panel – JR3	73
9.2.5	SNMP Card slots	73
9.3	UPS Monitoring and automated control software	73
9.3.1	The importance of UPS management	73
9.3.2	PowerREPORTER™ management software	74
<b>10</b>	<b>Specification</b>	<b>76</b>
10.1	Introduction	76
10.2	Mechanical data	76
10.2.1	UPS Cabinet	76
10.2.2	100 kVA UPS Power module	77
10.3	100 kVA UPS Module Data	77
10.4	General Data	78
10.4.1	Limitations to Runtime	79

## 1. Safety

### 1.1 Description of the safety symbols used in this manual



**WARNING:** The warning symbol is used where there is danger of an electrical shock, equipment damage or personal-injury.



**CAUTION:** The caution symbol is used to highlight important information to avoid possible equipment malfunction or damage.

### 1.2 User precautions



**WARNING:** Keep this manual with the UPS for future reference.



**WARNING:** The UPS and peripheral equipment must be installed by suitably qualified and trained personnel who are aware of the potential shock hazards.



**WARNING:** Do not attempt to install this UPS system until you are satisfied that you have read and understood all the safety and hazard warnings contained in this manual.



**WARNING:** Electrical power must be applied to the UPS before it has been commissioned by a fully trained engineer authorised by the manufacturer.



**WARNING:** All servicing must be performed by a qualified engineer approved by the manufacturer. Do not attempt to service the UPS yourself. You run risk of exposure to dangerous voltages if you open or remove the UPS covers! Rehiko will assume no responsibility or liability for accidents or injuries due to incorrect operation or manipulation of the UPS or peripheral equipment.



**CAUTION:** The Rehiko PW 9500DPA is a Class A UPS product (according to EN 62040-3).

*In a domestic environment the UPS may cause radio interference and the user may be required to undertake additional measures.*

### 1.3 Terminology

The following terms are used in this manual to describe various UPS system configurations.

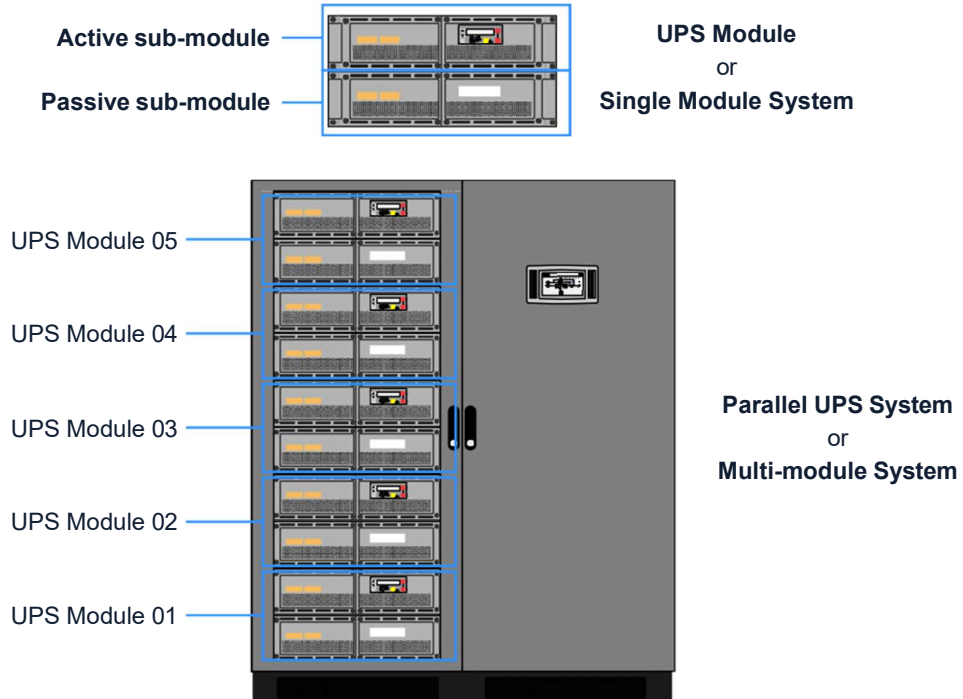

*Fully populated PW 9500DPA cabinet containing 5 x UPS Modules operating in parallel.*

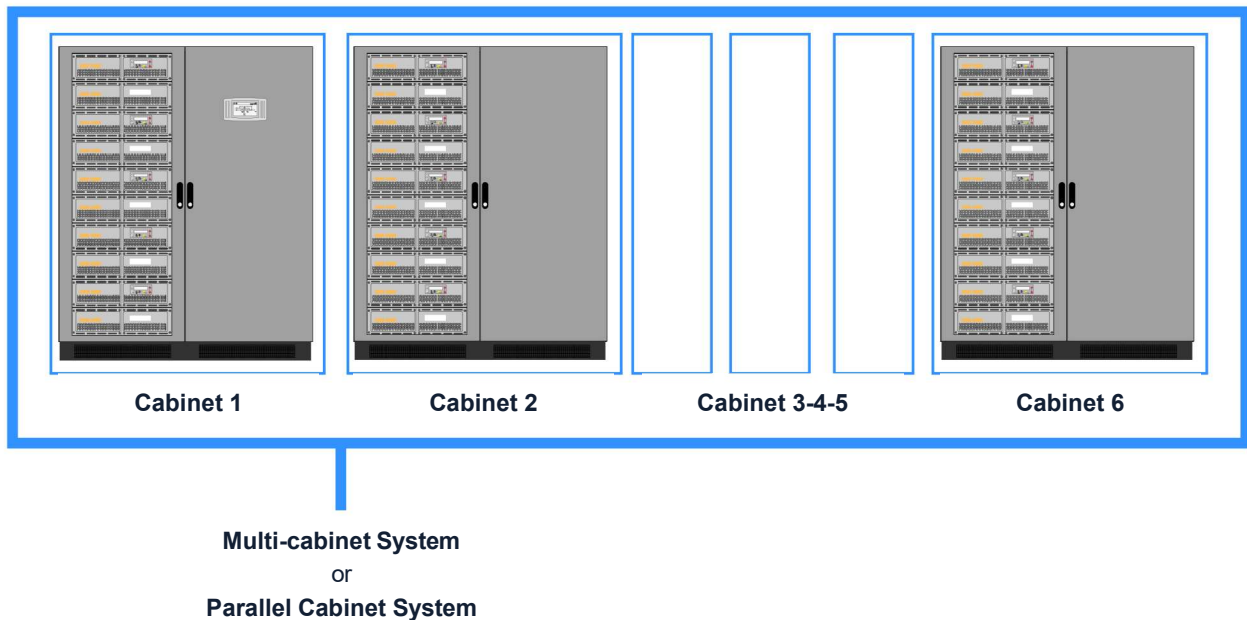

*Up to six PW 9500DPA cabinets can be connected in parallel to effectively offer a multi-module system containing up to 30 (6x5) parallel UPS Modules.*

## 2. General Description

### 2.1 Introduction

Congratulations on your purchase of the Rehiko PW 9500DPA UPS.

Continuous power availability is essential in today's dynamic IT and process-related work environments. It is equally important that any installed power protection system is sufficiently resilient and adaptable to handle changes brought about by the introduction of new server technologies, migration and centralization.

Such demands are well met by the PW 9500DPA UPS system, which provides the foundation for continuous power availability of network-critical infrastructures both in enterprise data centres, where business continuity has paramount importance, and in process control environments where manufacturing continuity is essential.

### Reliability and quality standards

The PW 9500DPA UPS incorporates the latest technological developments in power engineering. Representing a completely new generation of high power three phase UPS systems, its advanced double conversion VFI (Voltage and Frequency Independent) topology responds fully to both the highest availability and environmentally friendly requirements compliant with IEC 62040-3 (VFI-SS-111) standards.

Rehiko specialises in the installation and maintenance of Uninterruptible Power Systems; and this powerful UPS is just one example of our wide range of state-of-the-art power protection devices that will provide your critical equipment with a steady and reliable power supply for many years.

### Key features

High reliability, upgrade ability, low operating costs and excellent electrical performance are just some of the highlights of this advanced UPS system. Other key features include:

- *Decentralised Parallel Architecture (DPA)* – Each UPS module contains its own bypass circuit, which greatly improves the overall system reliability by removing a common point of failure that is often present in more traditional UPS systems.
- *Truly modular design* – The PW 9500DPA is designed around 100 kW rated UPS modules.
- *System expandability* – Each PW 9500DPA cabinet can contain up to five UPS modules (500 kW), and up to six cabinets can be connected together to offer a parallel system capacity of 3.0 MW.
- *Hot-swappable modules* – System expansion and module replacement can be carried out without disturbing the connected load.
- *Unity output power factor (kVA = kW)* – Blade server friendly. No de-rating required with leading PF loads.
- *Best in class AC-AC efficiency* – up to 96% efficiency minimises operational costs (TCO).
- *Xtra VFI double conversion mode* – A complementary feature which enhances the double conversion efficiency of the UPS when load power is low compared to total UPS system capacity.
- *Low input power factor (0.99 @ 100% load)* – Cost savings during installation and the entire life cycle (TCO).
- *Ease of operation* – A graphical display panel on the front of the UPS cabinet provides the operator with a single point of 'system level' control, and also allows the operation of each individual module to be interrogated.
- *Flexible battery management* – Advanced management of battery charging and preventive failure diagnostics avoids premature deterioration of battery life.
- *Top or bottom cable entry* – Allows flexible installation into existing plant infrastructure.
- *Very low input current distortion* – A THDi = <3.5% @ 100% load leads to savings in generator-set power and installation costs.

## 2.2 Model range

As described previously, the PW 9500DPA UPS cabinet can house up to five 100 kW UPS modules, so each cabinet can be rated up to 500 kW in 100 kW increments.

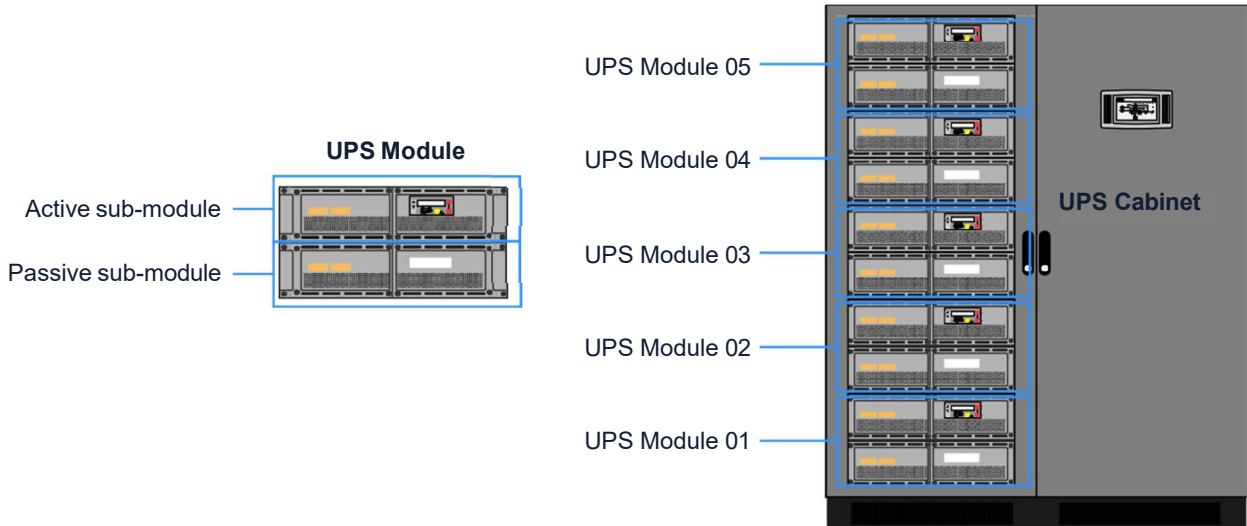

**Figure 2.1 Rehlko PW 9500DPA System hardware**

Each UPS module comprises two sub-modules; one is known as the 'Active' sub-module and the other as the 'Passive' sub-module. These are mounted in the UPS cabinet in pairs, with the Active sub-module installed on top of the Passive sub-module. The first module to be installed in the cabinet must be fitted to the bottom position with subsequent modules fitted in the next lowest available slot. Each installed module is assigned an ID number to allow it to be identified by the system control logic for purposes such as monitoring and event logging. The modules fitted in the first cabinet identified as illustrated above. In a multi-cabinet installation, the modules in the second cabinet are given an identity '06' to '10', those in the third cabinet are given '11' to '15' and so on...

The following table shows the static parameters for each configuration:

	1 Module	2 Module	3 Module	4 Module	5 Module
System power rating (per cabinet) (kVA/kW)	100	200	300	400	500
Cabinet weight including modules (kg)	539	648	757	866	975
Cabinet weight without fitted modules (kg)	430				
Cabinet dimensions (w x h x d) mm	1580 x 1975 x 940				
Heat dissipation 100% linear load (W)	4500	9000	13500	18000	22500
Heat dissipation 100% linear load (BTU)	15395	30717	46076	61434	76793
Heat dissipation 100% non-linear load (W)	4500	9000	13500	18000	22500
Heat dissipation 100% non-linear load (BTU)	15395	30717	46076	61434	76793
Heat dissipation no load (W)	660	1320	1980	2640	3300
Acoustic noise (@ 100% / 50% load)	75/67dBA (with 5 modules fitted)				
Cooling airflow (25°C - 30°C) at full load (m³/h)	1200	2400	3600	4800	6000
Installation clearances (mm)	Front 1500, Side 100, Rear 300, Top 400				
UPS Module weight	Active sub-module = 55 kg, Passive sub-module = 54 kg				
UPS Module dimensions (w x h x d) mm	Active & Passive modules 710 x 178 x 750				

## 2.3 UPS Module functional description

### 2.3.1 UPS Module internal operation

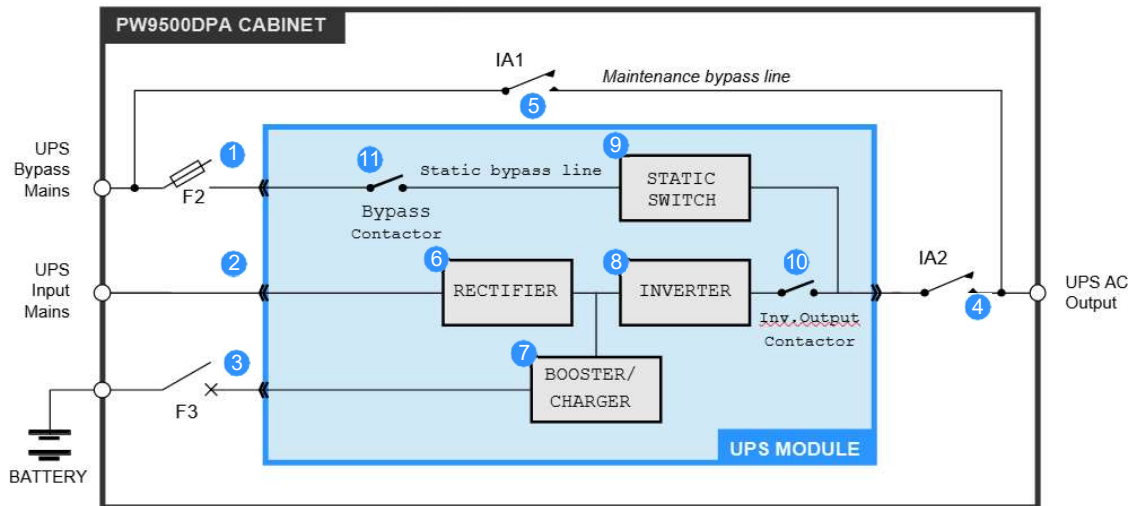

Figure 2.2 UPS module functional block diagram

Figure 2.2 shows an internal functional block diagram of a UPS module installed in a Rehlko PW 9500DPA cabinet.

#### UPS Module power inputs/outputs (1, 2, 3, 4)

When a UPS module is inserted into the cabinet rack it plugs into a heavy duty power socket located at the rear of the cabinet which carries the UPS module's input and output power connections, as shown.

- The UPS input mains (2) is not switched within the cabinet and is connected directly to the UPS module.
- The UPS bypass mains (1) is connected via by fuse F2. Each UPS module is individually fused, with the fuses labelled F2-x, where 'x' denotes the module position within the cabinet. For example the bypass input fuse for the module fitted to the lowest rack is F2-1, with F2-5 being used to identify the fuse for the top-most module.
- The UPS batteries are installed in an external enclosure and can be configured as a single battery string that is shared by all the UPS modules ('common battery' configuration), or connected as individual battery strings for each individual module ('separate battery' configuration). Irrespective of the external battery configuration, the battery connection to each UPS module (3) is individually protected by a circuit breaker F3-x, where 'x' denotes the module position within the cabinet, as described above.
- The UPS module a.c. output (4) is connected the cabinet output power terminal via an 'output isolator' switch (IA2). Once again, an individual isolator is provided for each UPS module, annotated IA1-1 IA1-5. In a redundant-
- module parallel UPS system IA2 can be used to disconnect the UPS module from the parallel system output to allow the module to be replaced, or tested, without affecting the remainder of the system.

*Note: In the majority of installations the UPS bypass mains and UPS input mains supplies are linked at the cabinets input power terminals in what is known as a 'common input' configuration. This then requires only one UPS mains supply feed.*

#### Maintenance bypass switch (Optional) (5)

When fitted, the maintenance bypass switch (IA1) (5) provides a means of bypassing ALL the UPS modules fitted in the PW 9500DPA cabinet and connects the cabinet's output power terminals directly to the UPS bypass mains supply. This switch can be used to provide the load with unprotected power temporarily if it is necessary to fully power down the UPS modules. Note that if a maintenance bypass option is required for a multi-cabinet UPS system, the maintenance bypass switchgear is installed in a separate, external panel and the UPS cabinet internal maintenance bypass switches (IA1) are not fitted – a typical external maintenance bypass installation is shown on Page 40.

### Rectifier (6)

The rectifier (6) converts the UPS input mains to a DC power source that can satisfy the inverter DC power demands over an input voltage range of between 160V~288V. This wide input voltage range means that the battery is not called upon even during substantial power dips (brown outs), which maximises battery life and availability. The rectifier control system uses leading-edge switched-mode techniques which achieves a UPS input power factor of almost unity over its operating range (0.99 at full rated linear load).

### Battery booster/charger (7)

This block has bi-directional functions. When the UPS mains input supply is available, and the rectifier is turned on, the booster/charger acts as a multi-stage battery charger which uses an intelligent charging profile to optimise the battery life and ensure the battery recharges quickly following a deep discharge cycle. If the input mains supply fails, or the rectifier is unable to provide a sufficient output to satisfy the prevailing inverter load, the battery provides the inverter's DC operating power source via the booster. The booster contains a DC-DC boost converter which boosts the battery voltage and provides a regulated DC input to the inverter as the battery discharges to allow the inverter to operate correctly.

### Inverter (8)

The inverter converts the DC voltage produced by the rectifier (or the battery via the boost converter) into a sinusoidal AC output voltage suitable to connect to the load. In addition to providing output voltage regulation, the inverter control logic also provides various levels of overload protection, frequency regulation and synchronisation, and output voltage error detection.

### Static switch (9)

The static switch provides a means of connecting the UPS module output to the static bypass line – which is in turn connected to the UPS bypass mains supply. Working in conjunction with the output contactor, the static switch control logic is used to transfer the UPS output from the inverter to the static bypass line without a break in the load supply in the event of an overload or UPS (inverter) malfunction.

*Note: A no-break transfer will take place if the inverter frequency and the bypass supply frequency is synchronised.*

### Inverter output contactor (10)

The inverter output contactor is driven by the UPS module's control logic and operates in conjunction with the static switch as part of the bypass/inverter load transfer process. The contactor is also used to isolate the inverter from the UPS output following certain overload or fault conditions.

### Bypass contactor (11)

The bypass contactor is used to isolate the bypass mains from static bypass line if the bypass supply is outside a specified, or if there is a sustained overload or bypass fault while the UPS is operating on bypass.

## 2.3.2 UPS Module operational states

The following simplified block diagrams are used to illustrate the standard operating modes of the UPS module.

### Inverter off (load on bypass)

Figure 2.3 shows the internal operation of the UPS module when mains power is first applied to the UPS or the inverter is turned OFF from the module control panel.

If the mains input supply is available, the battery charger continues to charge the battery and the static switch turns on to connect the UPS output to the bypass supply.

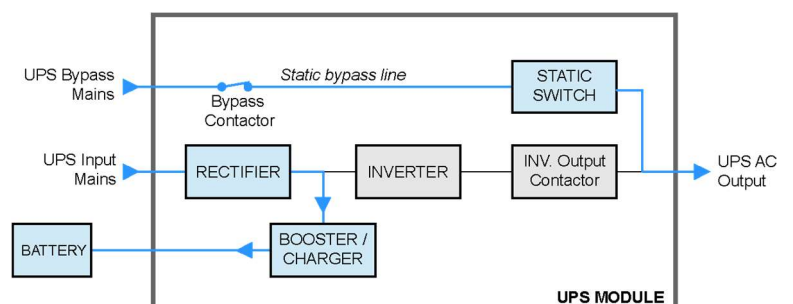

Figure 2.3 Inverter off

### UPS On-inverter mode

This is the only operating mode that provides the load with continuously processed and backed-up power: and in the majority of installations can be considered as the 'normal' operating mode.

In this mode, the UPS input mains is converted to DC by the rectifier which then charges the battery and provides the operating power for the inverter.

The inverter converts the DC produced by the rectifier back to an AC power source which is then connected to the load via the inverter output contactor.

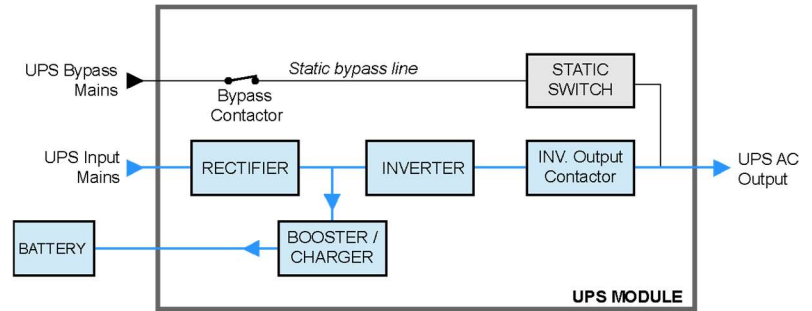

Figure 2.4 UPS On-inverter

The inverter frequency is synchronised to the bypass supply provided the bypass frequency remains within preset limits. If these limits are exceeded, or if the bypass supply fails altogether, the inverter frequency control reverts to a free-running oscillator which produces a constant 50Hz or 60Hz UPS output.

### UPS On-standby (Xtra VFI mode)

Figure 2.5 shows the internal operation of the UPS module when the Xtra VFI function is enabled and the UPS is operating on standby.

The rectifier is turned on and the battery charger remains active but the inverter is on standby, and ready when called upon by the Xtra VFI operation.

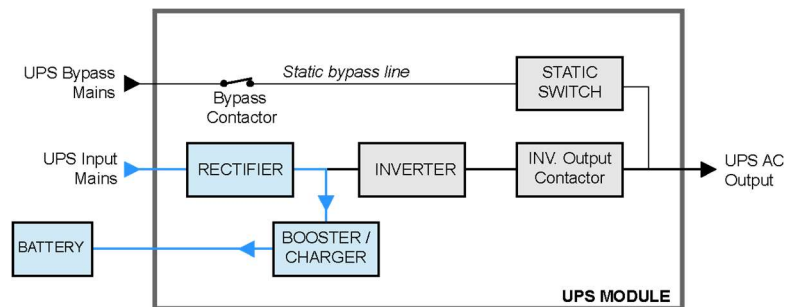

Figure 2.5 UPS On-standby

### UPS On-battery mode

If the input mains supply fails, the rectifier shuts down and the battery provides the DC power source for the inverter. The battery voltage is regulated by the booster circuit to ensure the inverter receives a suitable DC input voltage as the battery discharges. On the module control panel the BATTERY led will flash green to indicate that it is on load.

*In the case of a dual feed input* – if the bypass supply is still live when the input mains supply fails, the inverter frequency remains synchronised to the bypass mains provided it is within its preset limits.

*In the case of a single feed input* – the bypass supply will fail at the same time as the input mains supply and the inverter frequency control reverts to its free-running oscillator and will provide a constant 50Hz or 60Hz UPS output.

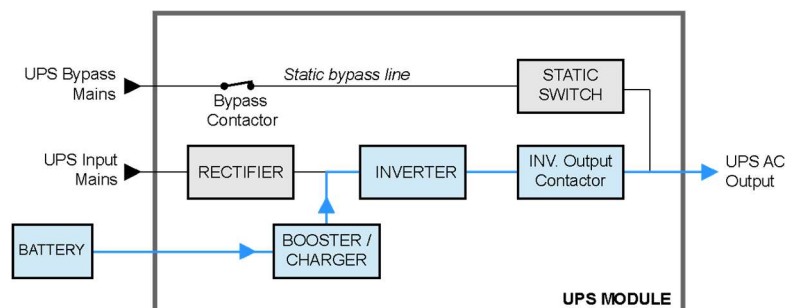

Figure 2.6 UPS On-battery

## Battery discharge operation

A Low Battery alarm is generated when the battery discharges to a preset level. This allows the operator to gauge the remaining autonomy time and, if necessary, shut-down the load in an orderly manner (e.g. save data) before the battery reaches its end-of-discharge voltage. Various options are available to automate the load shut-down process.

When the battery is initially put on load the BATTERY led flashes green on the UPS module control panel and this continues until the remaining autonomy time falls to 3 minutes whereupon the led begins flashing red. If an automated data protection application is installed it usually begins its shut down routine at this point.

The BATTERY led changes to solid red when the battery reaches its fully discharged voltage, and the UPS will attempt to transfer the load to the bypass supply if it is present.

## UPS On-bypass mode

In the 'on bypass' mode the static switch connects the load to the unprotected static bypass line. This mode can be selected manually (see 'ECO Mode' below) or entered as the result of a UPS fault or overload condition which transfers the load to bypass because the inverter is unable to support it. Depending on the reason for entering the 'load on bypass' mode, the rectifier and charger sections might be turned off entirely or remain operational and continue to charge the battery, as shown above. Similarly, the inverter may have been manually turned OFF or shut down due to a fault, and the INVERTER led on the module control panel may be either OFF or solid RED.

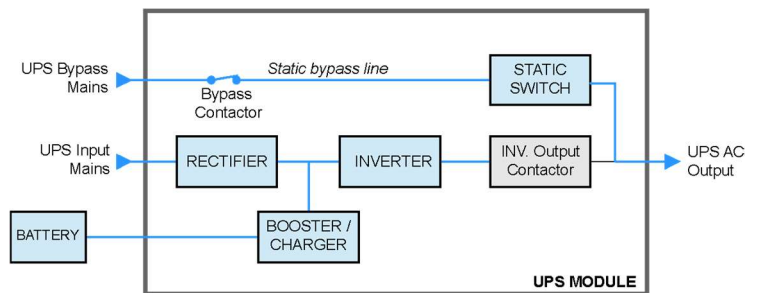

Figure 2.7 UPS On-bypass



**Key Point:** When several UPS modules are connected as a parallel system they must all operate with the same output mode – i.e. they must ALL be either 'on-inverter' or 'on-bypass'. So if you transfer the load between the inverter and bypass on one UPS module, every module in the system will automatically change state.

## Module OFF (Maintenance bypass)

*Note: The maintenance bypass facility is an optional feature.*

When all the UPS modules are turned OFF, the cabinet's maintenance bypass switch (IA-1) can be closed to maintain the load supply, but this requires the bypass mains supply to remain live and thereby prevents the cabinet's bypass supply from being externally isolated.

When operating a multi-cabinet system, the internal cabinet maintenance bypass switch is not normally fitted and an external maintenance bypass facility that wraps-around the complete multi-cabinet system is provided as part of the UPS system installation – see Page 40.

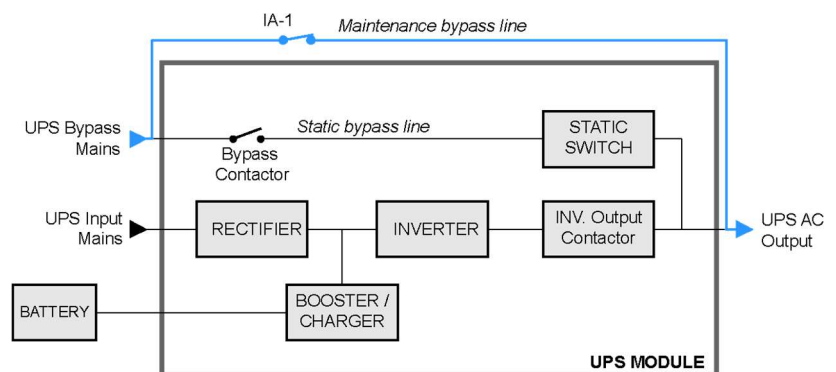

Figure 2.8 Module OFF (Load on maintenance bypass)

*Note: When switching to/from the maintenance bypass mode the UPS is normally transferred to the static bypass mode before the maintenance bypass switch is operated. This secures the load supply during the switching process.*

### 2.3.3 UPS system operating modes summary

Section 2.3.2 described the operating modes for the individual UPS modules within the PW 9500DPA cabinet: but entire UPS systems are also categorised according to the way in which they operate at a 'system' level, and are typically described as being either an 'on-line', or 'off-line' ('line interactive') system.

The Rehiko PW 9500DPA can be operated in either of these categories.

#### On-line UPS system

An 'on-line' UPS system provides the highest degree of load protection, especially if the utility mains supply suffers a disturbance or complete failure, and we always recommended this mode of operation if the critical load will not tolerate even a very brief supply interruption – e.g. in the case of a computer system.

When the Rehiko PW 9500DPA is used as an 'on-line' system, the UPS modules normally operate in their 'on inverter' mode (Figure 2.4), and switch to the 'on battery' mode if the input mains supply fails (Figure 2.6). The changeover to battery operation is totally transparent at the UPS output and an audible and visual alarm warns the operator that the battery is discharging to enable any intervention to be taken to protect the load integrity.

The UPS then continues to provide its rated output until the battery discharges to a low cut-off point at which time the UPS attempts to switch to its 'on bypass' mode (Figure 2.7). If the bypass is unavailable when the UPS attempts to transfer to it, the UPS shuts down in a controlled manner.

It is usual, especially in larger installations, to provide an alternative UPS input supply from a standby generator which starts automatically following a utility mains failure; and where this secondary power supply is implemented the batteries only discharge for a short period, until the generator comes on-line. This not only avoids the UPS shutting down due to a fully discharged battery but also helps maximise the battery life cycle.

If the UPS experiences an internal fault during 'on-line' operation, the inverter turns off and the static switch transfers the load to bypass mains automatically and without interruption – provided the inverter is synchronised to the bypass. If the problem is due to an output overload the inverter can supply the overload for a limited time, depending on its severity, and if the rated time is exceeded the UPS transfer the load to bypass. The additional power available from the bypass supply will attempt to clear the overload but if it persists it will ultimately rupture the bypass mains supply fuses. However, if the overload condition clears while operating on bypass the UPS re-transfers the load to the inverter and the UPS returns to its normal 'on-line' mode of operation.

#### Off-line (On stand-by) UPS system operation

When the Rehiko PW 9500DPA is used as an 'off-line' system, the UPS modules are normally operated in their 'on bypass' mode (Figure 2.7) with the load supplied via the static bypass line. However the rectifier and battery charger are still powered up and maintain battery charging, and the inverter section is turned on and operating on standby.

Operating in this mode is slightly more energy efficient than when operating in the 'on-line' mode due to the reduced rectifier and inverter losses during normal system operation; and it is sometimes referred to as the "ECO" (economy) mode. However, this mode is recommended only if the connected load equipment can tolerate power interruptions of up to 3~5 ms during the load transfer period.

If the bypass supply fails, the inverter is immediately brought on line and the load is transferred from the static bypass line to the inverter within 3~5 milliseconds. If the UPS bypass mains and input mains are connected to separate sources (dual feed) and the input mains is still live when the load is transferred, the UPS modules will operate in their 'on inverter' mode (Figure 2.4). However, if the input/bypass mains supplies are connected to a common feed, or the input mains is unavailable in a dual feed system, the modules immediately revert to the 'on battery' mode (Figure 2.6).

When the bypass supply returns to normal, the load re-transfers to the static bypass line (without a break) and the inverter returns to its standby operation.

*Note: if the bypass is unavailable it is unable to take over the load supply if the inverter fails, or assist the inverter handle an output overload. It is therefore important that the cause of the load transfer from bypass to inverter is quickly rectified.*



**WARNING:** The ON-LINE mode should always be used for critical load protection.

## 2.4 Parallel system operation

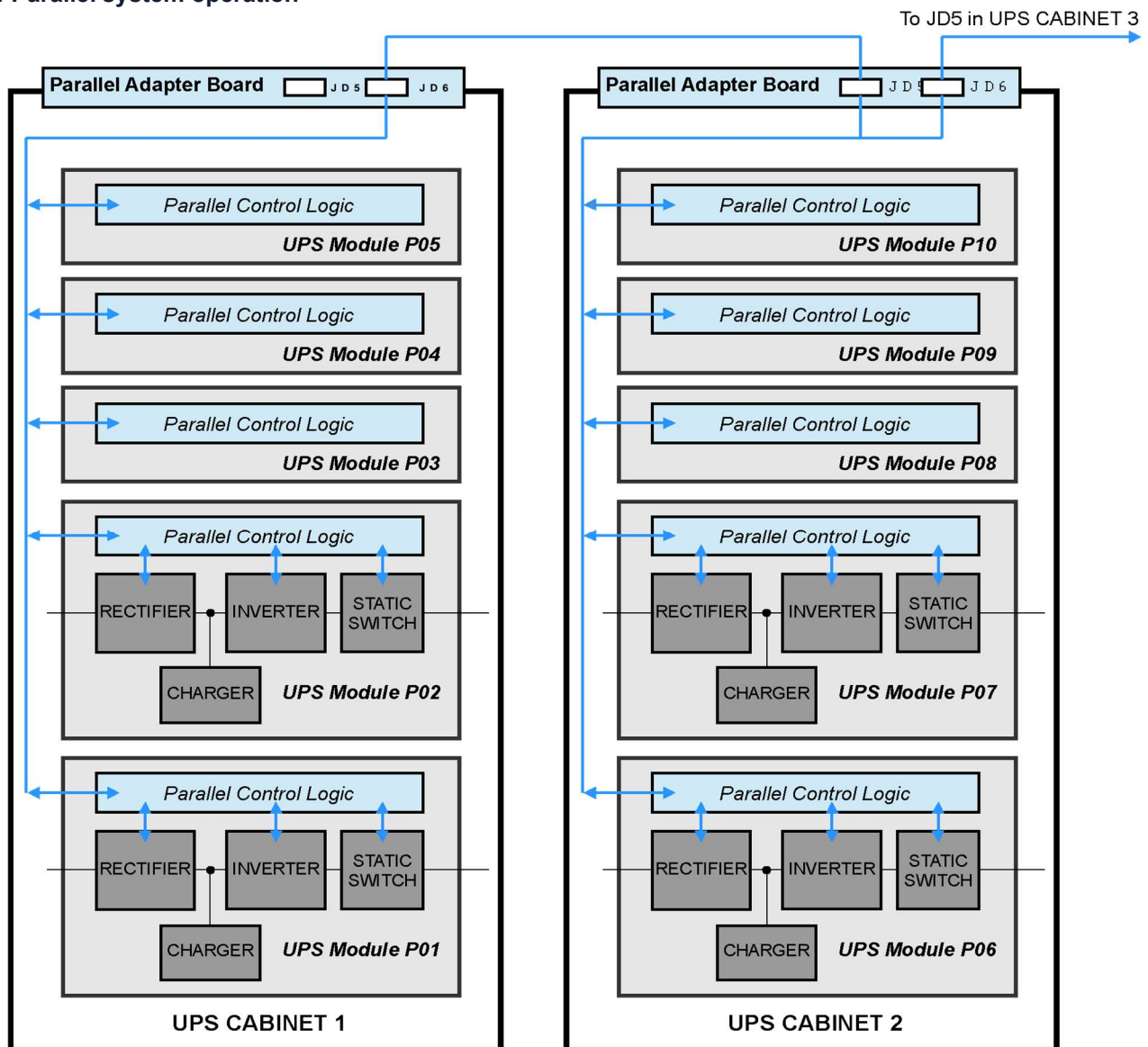

Figure 2.9 Rehlko PW 9500DPA – Parallel cabinet system

All the UPS modules fitted in a PW 9500DPA cabinet inherently operate as a parallel system as their outputs are connected in parallel at the cabinet's output terminals. The electronic control system built into each module ensures that:

- The modules are always frequency-synchronised to each other – and to the bypass mains (when present).
- The modules equally share the load current.
- The modules' load transfer operation is synchronised such they ALL transfer their output between inverter and bypass simultaneously when commanded from any one module.

The Rehlko PW 9500DPA UPS system can be expanded by connecting the outputs of up to six PW 9500DPA UPS cabinets in parallel; and when two or more cabinets are connected in this way, all the UPS modules within them are effectively paralleled together. A maximum system capacity is obtained by connecting together six fully populated PW 9500DPA cabinets, which results in a total of thirty (100kVA) modules operating in parallel with a system capacity of 3000kVA.

## System expansion

Some UPS applications present a low initial power requirement which increases over time as the application grows; so it is essential that the installed UPS system can be expanded to meet the growing demand without compromising the existing load. This requirement is well met with the 'hot swappable' feature of the Rehiko PW 9500DPA UPS, whereby an additional module can be inserted into a vacant slot in an existing cabinet without disturbing the load.

*Note: If the expansion requires an additional cabinet the system will have to be shut down while the cabinet is installed.*



**Key Point:** When planning a multi-cabinet system, it is not necessary to fully populate one cabinet with UPS modules before installing the next cabinet. For example, if it is known at the outset that a 400kVA initial load requirement is likely to increase to a maximum of 900kVA, it makes sense to install and cable-up two cabinets and distribute the initial requirement of four UPS modules between them then add further modules as required.

## 'Capacity' versus 'redundant' module system

A parallel UPS system can be operated as either a 'capacity' or 'redundant' module system.

A 'capacity' system is rated such that ALL the UPS modules are required to furnish the specified full load power and the loss of one module will automatically transfer the load to the bypass supply.

In a 'redundant-module' system, the system contains at least one UPS module over and above that required to supply the full load and it is therefore possible to lose one module without needing to transfer the load to the bypass supply or in any way disrupt the UPS output. A system operating with a redundant module is inherently the most reliable.

A parallel UPS system operating with one redundant module is known as an 'N+1' system.

## Parallel control bus

All the UPS modules within a cabinet, and between cabinets, are connected to a parallel control bus which carries several control signals used for frequency synchronisation, load sharing etc, as shown in Figure 2.9. This allows each UPS module to electronically compare its own frequency and output current with that of its neighbouring module and make any necessary fine adjustments to its control system to achieve balanced conditions across the system.

The parallel control system observes one UPS module as being the 'master' and the others as 'slaves'. However if the 'master' module goes faulty the next module in the chain (a former 'slave') will immediately take over the role of 'master' and the former 'master' module will turn off. The 'master/slave' configuration is set during commissioning.

## 2.5 Xtra VFI mode

### 2.5.1 Introduction

The parallel control mechanism described above ensures that the operational UPS modules in a Rehiko PW 9500DPA system equally share the load current. However, when the connected load is small in comparison with the system capacity, the current required from each module can be sufficiently low that it adversely affects the module's efficiency.

The graph below shows that the efficiency of a standard Rehiko PW 9500DPA UPS module remains at around 96% for loads of 90% down to approximately 35%, but thereafter the efficiency begins to fall off to approximately 88% @7.5% load. This reduced efficiency at low load represents wasted energy and expense, and is alleviated by the Xtra VFI feature which dynamically controls the number of on-line UPS modules in line with changes in load demand.

Xtra VFI calculates the number of UPS modules necessary to supply the prevailing load such that current drawn from each one places it in the higher range of its efficiency curve and only turns on the required number of modules. Surplus modules are placed in a 'standby' mode, with their inverters turned off, and can be brought back on-line within 40~50ms when the system load increases. The overall effect of Xtra VFI can improve the system efficiency by up to 5% at very light loads, as shown in Figure 2.10.

Xtra VFI is an in-built feature, available in every Rehiko PW 9500DPA system, and can be enabled or disabled by a qualified service engineer with access to the password-protected Service menu on the system control panel.

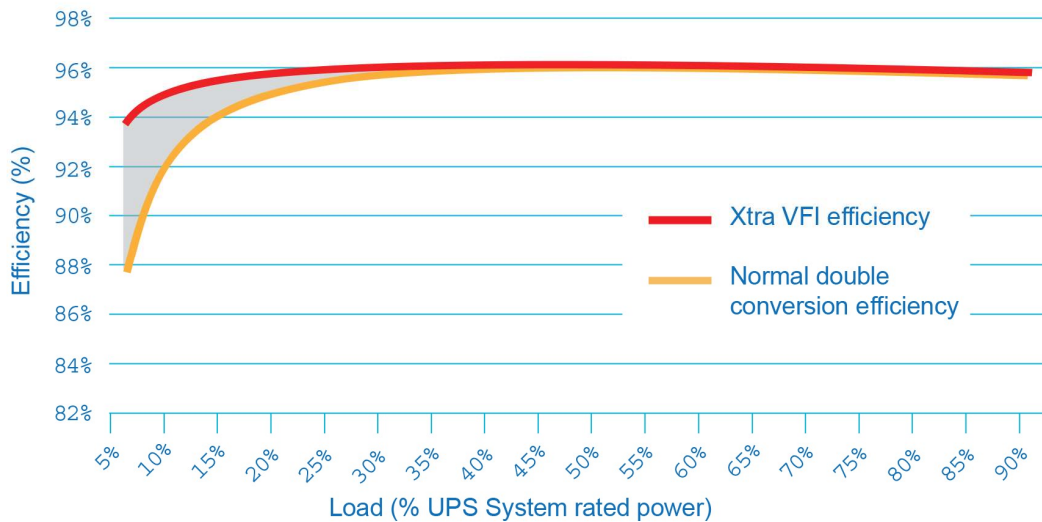

**Figure 2.10 Efficiency diagram with and without Xtra VFI**

## 2.5.2 Operation

### UPS Module standby operation and rotation

When Xtra VFI is operational it switches all non-required UPS modules to 'standby' mode whereupon the inverter is turned off to reduce the module's power consumption but the rectifier and battery charger remain active – the Inverter LED on the module control panel indicates yellow when the module is operating on standby.

The Xtra VFI status can be observed on two screens on the system control panel, as shown in figures 3.7 and 3.17.

The active (on-line) UPS modules are rotated on a weekly basis to balance their use over time. This is done automatically by the Xtra VFI control logic which turns on the in-coming modules before switching the outgoing modules to standby.

An xVFI ROTATING status message is generated at the start of the module rotation process and this is succeeded by xVFI ACTIVE once the rotation has completed successfully.

Xtra VFI does not require any user intervention during the day-to-day operation of the UPS system. Once the Xtra VFI feature is enabled it will remain permanently active as long as the following conditions are met:

- There is no active system alarm.
- All the UPS modules within the system are turned on.
- The number of modules in the system is equal to the "Total UPS Number" entered in the Xtra VFI setup screen by the service engineer.
- The output isolator (IA2) is closed for every UPS module.
- A battery test is not being run.

### Xtra VFI setup

The service engineer must enter three parameters in the Xtra VFI setup menu:

- Highest Load Step (HLS) – corresponds to the highest load step to be expected in the system (in <50 ms) that the UPS system must be able to handle without compromise. This can be entered as a percentage of the system capacity or in kW.
- Redundancy level – the number of redundant modules required.
- Total UPS number – the total number of UPS modules contained in the system.

The Xtra VFI feature takes these parameters into account when calculating the required number of on-line modules for any given load.

## 2.6 Rehiko PW 9500DPA Operator controls

This section describes the switches and control panels illustrated in Figure 2.11 that are used to operate and monitor the Rehiko PW 9500DPA UPS system.

### 2.6.1 Power switches

Each UPS module has three associated power isolators (F2, F3, IA2) located in the right hand cabinet. The electrical position of these are shown in Figure 2.2. In order to make system expansion straightforward, all the isolators shown are fitted to the cabinet as standard even if the cabinet is not initially fully populated. This allows additional modules to be inserted into a vacant cabinet slot without needing to shut down the system to carry out additional mechanical or cabling work. In a parallel-cabinet system the (optional) maintenance bypass switch is contained in an external bypass facility so the internal maintenance bypass switch (IA1) is not fitted to the cabinet.

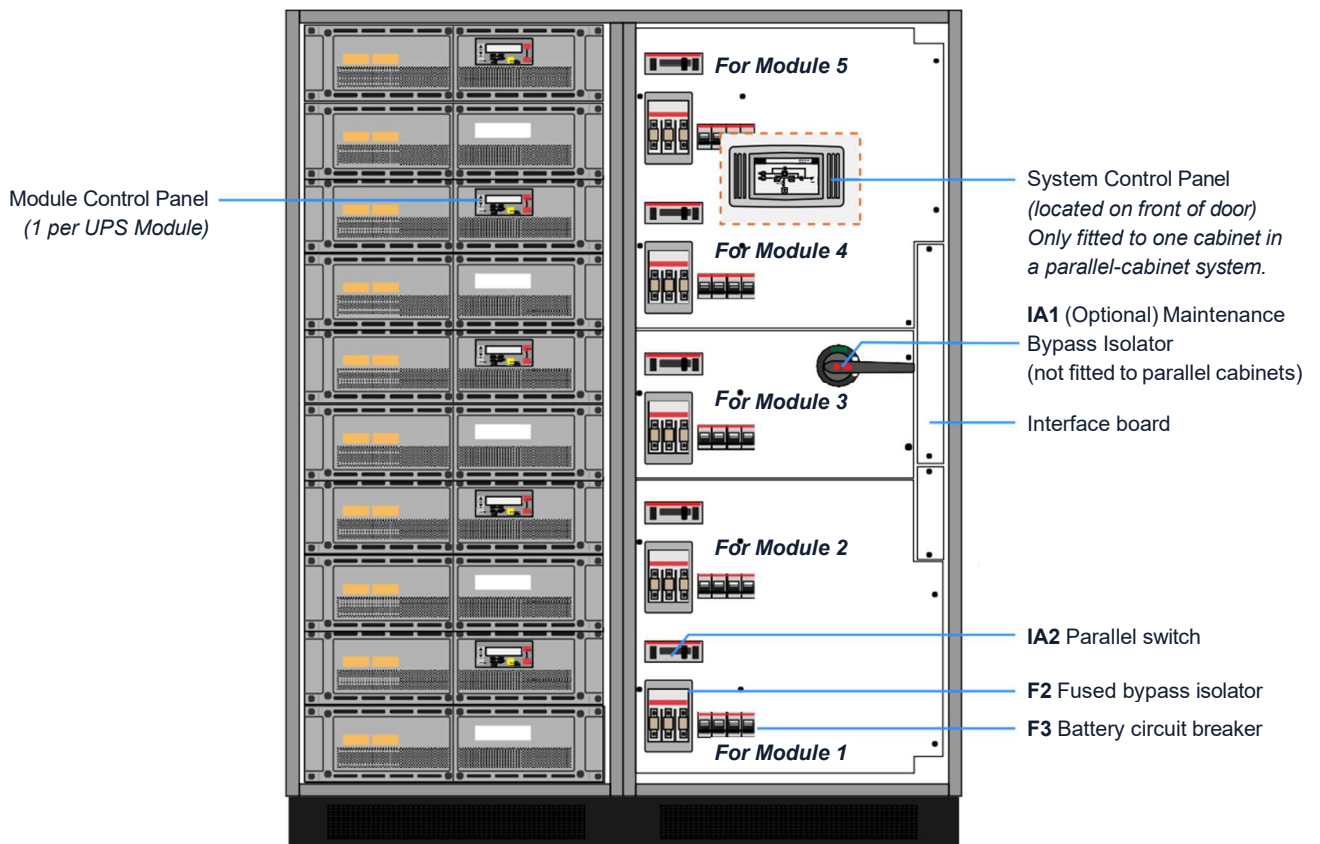

Figure 2.11 Power fuses and isolator switches

## 2.7 UPS Module control panel

A control panel is fitted to the front of each UPS module. During normal operation the control panel can be used by the operator to start/stop the module as part of the UPS system operating procedures, monitor the module's operating performance and manually transfer the load between inverter and bypass. The control panel is also used by a trained service engineer to test and set-up the module's operating parameters during troubleshooting and commissioning.

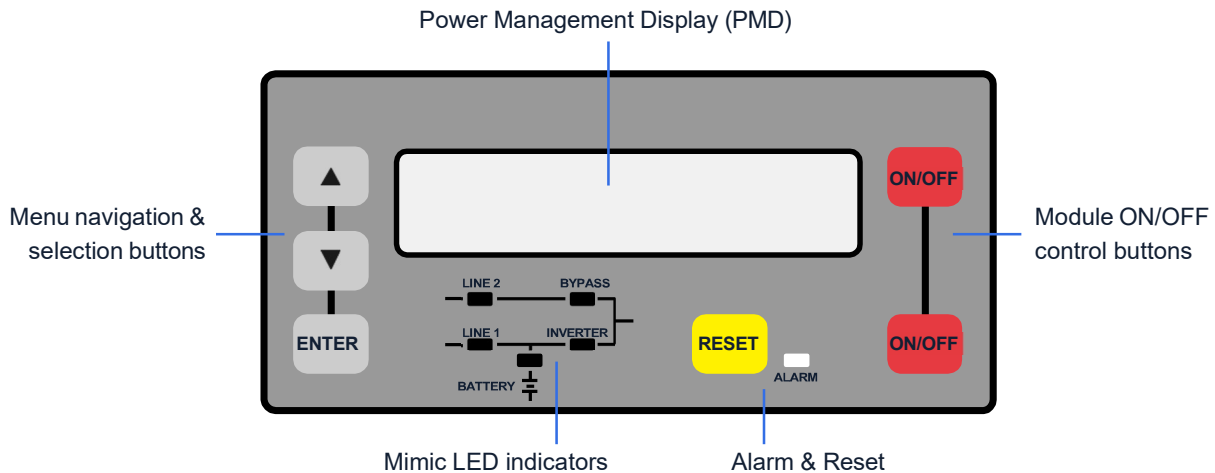

Figure 2.12 UPS Module control panel

### 2.7.1 Module control panel buttons

The module control panel buttons allow you to:

- Start-up and shut-down the UPS and transfer the load between inverter and bypass.
- Monitor and display the UPS operating voltages, currents, frequencies and other values on the LCD display.
- Reset/cancel an alarm.

BUTTON	FUNCTION
ON/OFF	Used to switch-on or switch-off the UPS by pressing both buttons simultaneously
UP (▲)	Scroll upwards through a displayed menu
DOWN (▼)	Scroll downwards through a displayed menu
ENTER	Selects a chosen menu item
RESET	Cancels an audible alarm. If the alarm condition is transient the alarm LED will turn off, otherwise it will remain on

You can switch the UPS module on or off by simultaneously pressing both ON/OFF buttons (for less than 1s). The requirement to press both buttons is intended to help prevent accidental operation.

Pressing the two ON/OFF buttons during normal operation will immediately shut down the UPS module. The load may or may not transfer to the static bypass, depending on whether or not the number of remaining on-line UPS modules satisfies the system's redundancy – i.e. if there is a sufficient number of modules remaining to support the system's load then the load is not transferred.

**To shut down all the UPS modules in a parallel system you must press both ON/OFF buttons on every module.**

### 2.7.2 Mimic LED Indication

The mimic diagram LEDs indicate the general power flow through the UPS module and changes colour between Green and Red (and OFF) to indicate the prevailing UPS module operating conditions.

INDICATOR	INDICATOR STATUS	INTERPRETATION
LINE 1	GREEN RED OFF	Input (rectifier) mains available Input (rectifier) mains unavailable No input (rectifier) supply (UPS Turned off)
LINE 2	GREEN RED OFF	Bypass mains available (bypass OK) Bypass mains unavailable (bypass supply error) No bypass supply (UPS Turned off)
ALARM*	OFF Flashing RED + buzzer RED	No alarm condition Alarm condition Alarm condition present (audio has been reset)
INVERTER	GREEN RED YELLOW OFF	Load on inverter Inverter fault or load transfer to inverter inhibited Inverter in standby mode (valid for Xtra VFI operation only) Inverter not operating (switched off)
BY-PASS	GREEN OFF	Load on bypass (or in ECO mode) Bypass not operating (turned off)
BATTERY	GREEN RED Flashing GREEN	Battery OK Battery faulty or discharged Battery on load (discharging) or battery breaker (F3) open

\* The ALARM LED is a visual indication of an internal or external alarm condition. When activated, it is accompanied by an audible warning which can be cancelled by pressing the RESET button.

### 2.7.3 Power Management Display (PMD)

A 2 x 20 character LCD Display simplifies communication with the UPS module and provides monitoring information. The menu driven LCD provides:

- Access to an 'event' register
- Input and output voltage, current, frequency & power monitoring
- Battery run time monitoring
- Access to commands such as module load transfer between INVERTER and BYPASS
- Access to the module's diagnostics registers (service mode only)
- Access to module adjustments and testing (service mode only)

#### Status screens

DESCRIPTION	LCD-DISPLAY
1. Load is protected and being supplied by the UPS inverter (Normal Operation).	LOAD PROTECTED P01
2. Load is not protected by UPS. It is either connected to the bypass (load on bypass) or connected to the inverter but with a battery problem.	LOAD NOT PROTECTED P01
3. Load supply completely powered-down. UPS modules have all been switched off by "ON/OFF" buttons.	LOAD OFF SUPPLY FAILURE P01
4. UPS module is not supplying load. The UPS output switch (IA2) is open.	LOAD DISCONNECTED PARALLEL SWITCH OPEN P01

The two-digit number on the right hand side of the LCD indicates the power module ID number (see Figure 2.9).

### Status screens

DESCRIPTION	LCD-DISPLAY				
1. Single module systems.	<table border="1"> <tr> <td>SYSTEM CONFIGURATION SINGLE</td> <td>S</td> </tr> </table>	SYSTEM CONFIGURATION SINGLE	S		
SYSTEM CONFIGURATION SINGLE	S				
2. Parallel System – e.g. bottom module in cabinet 2.	<table border="1"> <tr> <td>SYSTEM CONFIGURATION PARALLEL</td> <td>PO 6</td> </tr> </table>	SYSTEM CONFIGURATION PARALLEL	PO 6		
SYSTEM CONFIGURATION PARALLEL	PO 6				
3. Parallel System – e.g. top module in cabinet 3.	<table border="1"> <tr> <td>LOAD OFF</td> <td>P1</td> </tr> <tr> <td>SUPPLY FAILURE</td> <td>5</td> </tr> </table>	LOAD OFF	P1	SUPPLY FAILURE	5
LOAD OFF	P1				
SUPPLY FAILURE	5				

### Main menu screen

DESCRIPTION	LCD-DISPLAY	
1. Provides access to a log of the last 64 stored events.	<table border="1"> <tr> <td>→ EVENT LOG MEASUREMENTS</td> </tr> </table>	→ EVENT LOG MEASUREMENTS
→ EVENT LOG MEASUREMENTS		
2. Provides access to voltages, power, frequencies, currents, autonomy monitor screens.	<table border="1"> <tr> <td>→ MEASUREMENTS COMMANDS</td> </tr> </table>	→ MEASUREMENTS COMMANDS
→ MEASUREMENTS COMMANDS		
3. Provides access to the 'Load to inverter', 'Load to bypass' and 'battery test' commands.	<table border="1"> <tr> <td>→ COMMANDS UPS DATA</td> </tr> </table>	→ COMMANDS UPS DATA
→ COMMANDS UPS DATA		
4. Allows personalised UPS data (such as serial number) to be entered.	<table border="1"> <tr> <td>→ UPS DATA SET-UP USER</td> </tr> </table>	→ UPS DATA SET-UP USER
→ UPS DATA SET-UP USER		
5. Allows the user to set up Date/Time, automatic battery test, etc.	<table border="1"> <tr> <td>→ SET-UP USER SET-UP SERVICE</td> </tr> </table>	→ SET-UP USER SET-UP SERVICE
→ SET-UP USER SET-UP SERVICE		
6. This is a password-protected area for service engineer use only.	<table border="1"> <tr> <td>→ SET-UP SERVICE</td> </tr> </table>	→ SET-UP SERVICE
→ SET-UP SERVICE		

### Event log menu screen

DESCRIPTION	LCD-DISPLAY		
1. Logging Control; a log of the last stored 64 events.	<table border="1"> <tr> <td>01 05-10-08 LOAD TO INV.</td> <td>14-38-56</td> </tr> </table>	01 05-10-08 LOAD TO INV.	14-38-56
01 05-10-08 LOAD TO INV.	14-38-56		
2. Every stored event is identified with a sequential number and time stamp.	<table border="1"> <tr> <td>02 05-10-08 LOAD TO BYP.</td> <td>14-38-59</td> </tr> </table>	02 05-10-08 LOAD TO BYP.	14-38-59
02 05-10-08 LOAD TO BYP.	14-38-59		
3. By pressing ENTER the code of the event will be displayed.	<table border="1"> <tr> <td>03 05-10-08 LOAD OFF</td> <td>14-39-14</td> </tr> </table>	03 05-10-08 LOAD OFF	14-39-14
03 05-10-08 LOAD OFF	14-39-14		

## Measurements menu screen

DESCRIPTION	LCD-DISPLAY
1. Battery Runtime	BATT. RUN TIME (MIN) 00h 00mm
2. UPS-Output Frequency	OUTPUT FREQUENCY (HZ) 50.00
3. Bypass Frequency.	BYPASS FREQUENCY (HZ) 50.00
4. Battery Voltage	BATTERY VOLTAGE (V) +0.0 - 0.0
5. Battery Charger Current	BATT. CHARGE CUR. (A) + 0.0 - 0.0
6. Battery Discharge Current.	DISCHARGE CURRENT (A) 00.00
7. Rectifier Voltage (all three phases)	RECTIFIER VOLTAGE (V) 00.00 00.00 00.00
8. Bypass Voltage (all three phases)	BYPASS VOLTAGE (V) 00.00 00.00 00.00
9. Output Voltage (all three phases)	OUTPUT VOLTAGE (V)0 0.00 00.00 00.00
10. Output Current (all three phases)	OUTPUT CURRENT (A)0 0.00 00.00 00.00
11. Active Output Power (all three phases)	ACTIVE POWER (KW) 00.00 00.00 00.00
12. Reactive Output Power (all three phases)	REACTIVE POWER (kVAr) 00.00 00.00 00.00
13. Apparent Output Power (all three phases)	APPARENT POWER (KVA) 00.00 00.00 00.00
14. Output Power (all three phases)	OUTPUT POWER (%) 00.00 00.00 00.00
15. Battery capacity	BATT. CAPACITY (%) 00.00

## Commands menu screen

DESCRIPTION	LCD-DISPLAY
1. Transfer Load to inverter	→ LOAD TO INVERTER LOAD TO BYPASS
2. Transfer Load to bypass.	→ LOAD TO BYPASS PERFORM BATT.TEST
3. Battery Test	→ PERFORM BATT.TEST

### UPS Data menu screen

DESCRIPTION	LCD-DISPLAY		
1. These general UPS Data are installed at the manufacturing plant.	<div style="border: 1px solid black; padding: 2px;">           UPS SERIAL NUMBER nn-nnnnn         </div>		
2. Manufacturing date	<div style="border: 1px solid black; padding: 2px;">           DATE OF MANUFACTURE 15-03-16         </div>		
3. EPROM Version	<div style="border: 1px solid black; padding: 2px;">           EPROM VERSION V- 000         </div>		
4. Actual Date and Time	<table border="1" style="width: 100%; border-collapse: collapse;"> <tr> <td style="width: 50%; padding: 2px;">DATE dd-mm-yyyy</td> <td style="width: 50%; padding: 2px;">TIME hh:mm:ss</td> </tr> </table>	DATE dd-mm-yyyy	TIME hh:mm:ss
DATE dd-mm-yyyy	TIME hh:mm:ss		

### Set-up User menu screen

DESCRIPTION	LCD-DISPLAY
1. Set-up language	<div style="border: 1px solid black; padding: 2px;">           → SET LANGUAGE SET DATE AND TIME             ENGLISH FRANCAIS POLISH         </div>
2. Set-up Date and Time	<div style="border: 1px solid black; padding: 2px;">           → SET-UP DATE/TIME SET-UP BATT. TEST DD-MM-YY      HH-MM-SS         </div>
3. Set-up battery test	<div style="border: 1px solid black; padding: 2px;">           → SET-UP BATT. TEST SET-UP GEN-SET OPER. DAY OF MONTH (1-31) HOUR OF DAY (0-23) REPETITIVE (Y/N) 000         </div>
4. Set-up operation with Gen-Set	<div style="border: 1px solid black; padding: 2px;">           → SET GENERATOR OP.             BATT.CHARGE LOCK (Y/N)            BYPASS LOCK (Y/N)         </div>

### Set-Up Service menu screen



**Key Point:** This area is password protected and access is restricted to approved Service Engineers only.

## 2.8 System control panel

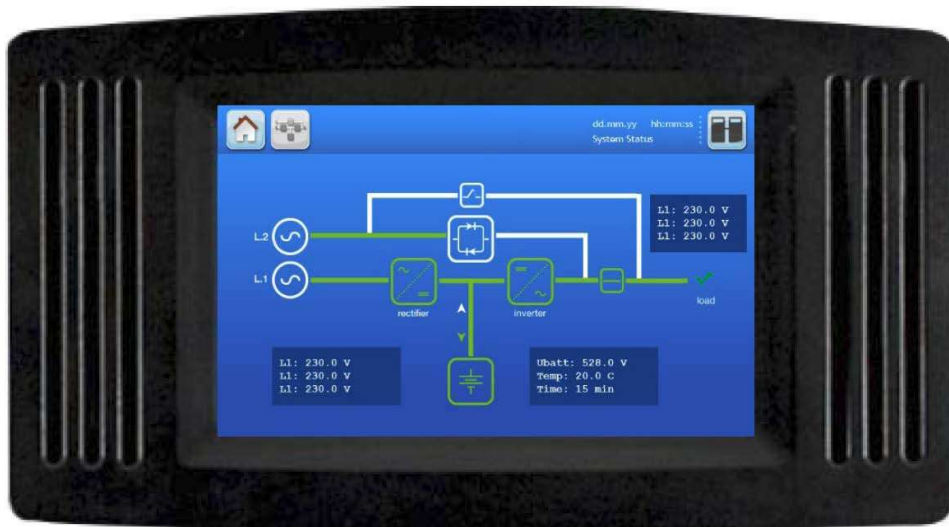

**Figure 2.13 System control panel default display**

The system control panel contains a TFT touch-screen display which enables you to monitor and operate the UPS installation at a 'system' level. A detailed description of the control panel is provided in Chapter 3.

## 2.9 Customer interface board

A customer interface board, which is fitted in the right-hand side of each UPS cabinet, provides a means of connecting the cabinet to a range of external monitoring and control facilities. It also allows the connection of the communications bus between the individual UPS cabinets in a multi-cabinet installation which is required to effect its parallel control operation.

The external monitoring and control facilities available for use in conjunction with the interface board are described in the Options chapter of this manual.

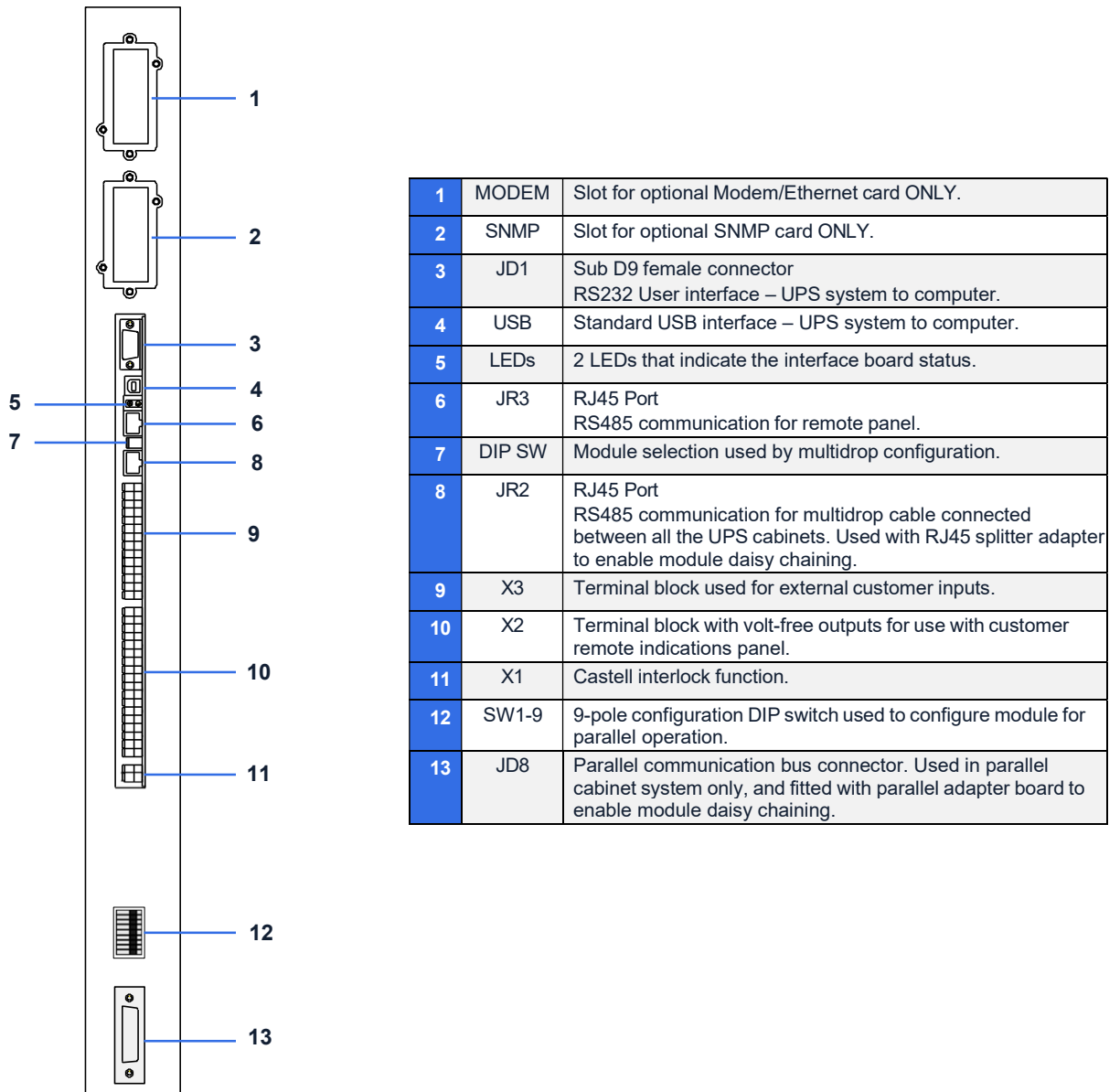

Figure 2.14 UPS Cabinet interface board

## 2.10 Warranty

The Rehiko PW 9500DPA UPS is supplied with a limited warranty that the UPS and its component parts are free from defects in materials and workmanship for a period of one year from the date of original commissioning, or fifteen months from the date of original delivery, whichever is the sooner. This warranty is the only warranty given and no other warranty, express or implied, is provided.

This warranty is invalidated if the UPS is used without having first been commissioned by a fully trained and authorised person. This warranty does not apply to any losses or damages caused by misuse, abuse, negligence, neglect, unauthorised repair or modification, incorrect installation, inappropriate environment, accident, act of God or inappropriate application.

If the UPS fails to conform to the above within the warranty period then Rehiko will, at its sole option, repair or replace the UPS. All repaired or replaced parts will remain the property of Rehiko.

As a general policy, Rehiko does not recommend the use of any of its products in life support applications where failure or malfunction of the product can be reasonably expected to cause failure of the life support device or to significantly affect its safety or effectiveness. Rehiko does not recommend the use of any of its products in direct patient care. Rehiko will not knowingly sell its products for use in such applications unless it receives in writing assurances satisfactory to Rehiko that the risks of injury or damage have been minimized, the customer assumes all such risks and the liability of Rehiko is adequately protected under the circumstances.



**CAUTION:** *The UPS system may contain batteries which must be re-charged for a minimum of 24 hours every six months to prevent deep-discharging. Batteries that have been, for whatever reason, deeply-discharged are not covered by the warranty.*

## 2.11 Extended Warranty

The Standard Warranty may be enhanced by protecting the UPS with an Extended Warranty Agreement (maintenance contract). An Extended Warranty Agreement enhances the standard warranty by providing:

- Regular preventative maintenance inspections
- Guaranteed speed of response to operational problems
- 24 hour telephone support
- Fully comprehensive (excluding batteries) cover

Contact the Service Support Hotline on 0800 731 3269 (24Hr.) for further details

## 2.12 Additional Service/Maintenance Support

If you are interested in obtaining an extended warranty for your Rehiko PW 9500DPA, or require service/maintenance support for any other UPS you may have, please contact Rehiko at the following address:

### UK

[www.ups.rehiko.co.uk](http://www.ups.rehiko.co.uk)

[ukservice.ups@rehiko.com](mailto:ukservice.ups@rehiko.com)

[uktechnicalsupport.ups@rehiko.com](mailto:uktechnicalsupport.ups@rehiko.com)

[uksales.ups@rehiko.com](mailto:uksales.ups@rehiko.com)

[ukservicesales.ups@rehiko.com](mailto:ukservicesales.ups@rehiko.com)

Rehiko web site

Service department – booking service, fault reporting etc.

Technical queries

Hardware sales

Extended warranty agreements etc

### IRELAND

[www.ups.rehiko.ie](http://www.ups.rehiko.ie)

[ieinfo.ups@rehiko.com](mailto:ieinfo.ups@rehiko.com)

Rehiko web site

Service department, technical queries, hardware sales and extended warranty agreements

### SINGAPORE

[www.ups.rehiko.sg](http://www.ups.rehiko.sg)

[salesups.sg@rehiko.com](mailto:salesups.sg@rehiko.com)

[serviceups.sg@rehiko.com](mailto:serviceups.sg@rehiko.com)

Rehiko web site

Hardware sales

Contract customer support, maintenance contracts renewals

### 3. System Control Panel

#### 3.1 Introduction

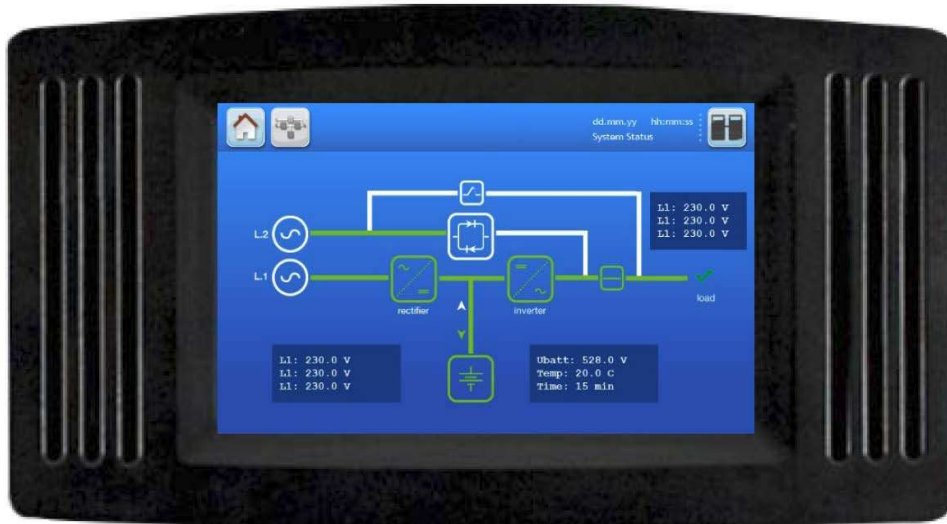

**Figure 3.1 System control panel default display**

The system control panel contains a microprocessor-based TFT touch-screen display which enables you to monitor and operate the UPS installation at a 'system' level. Only one system control panel is fitted to a multi-cabinet system – usually installed on the door of the cabinet that contains the 'master' UPS module (Module 01).

The system control panel displays the operational status of the overall UPS system as well as that of each individual UPS module. It enables you to:

- view the input/output/battery operating parameters (voltage, current, frequency etc.) for the entire system
- view the input/output/battery operating parameters (voltage, current, frequency etc.) for a selected UPS module
- execute a load transfer between inverter and bypass, and vice-versa
- monitor the power flow through the UPS system or selected UPS module, through an illuminated, colour-coded mimic diagram
- check alarm and events histories
- acknowledge an event occurrence
- silence alarms
- monitor the battery state and autonomy time

### 3.1.1 Display Header Bar

Figure 3.2 illustrates the display header bar that is presented at the top of every screen. It contains number of touch-sensitive icon buttons, and also displays some key system status information.

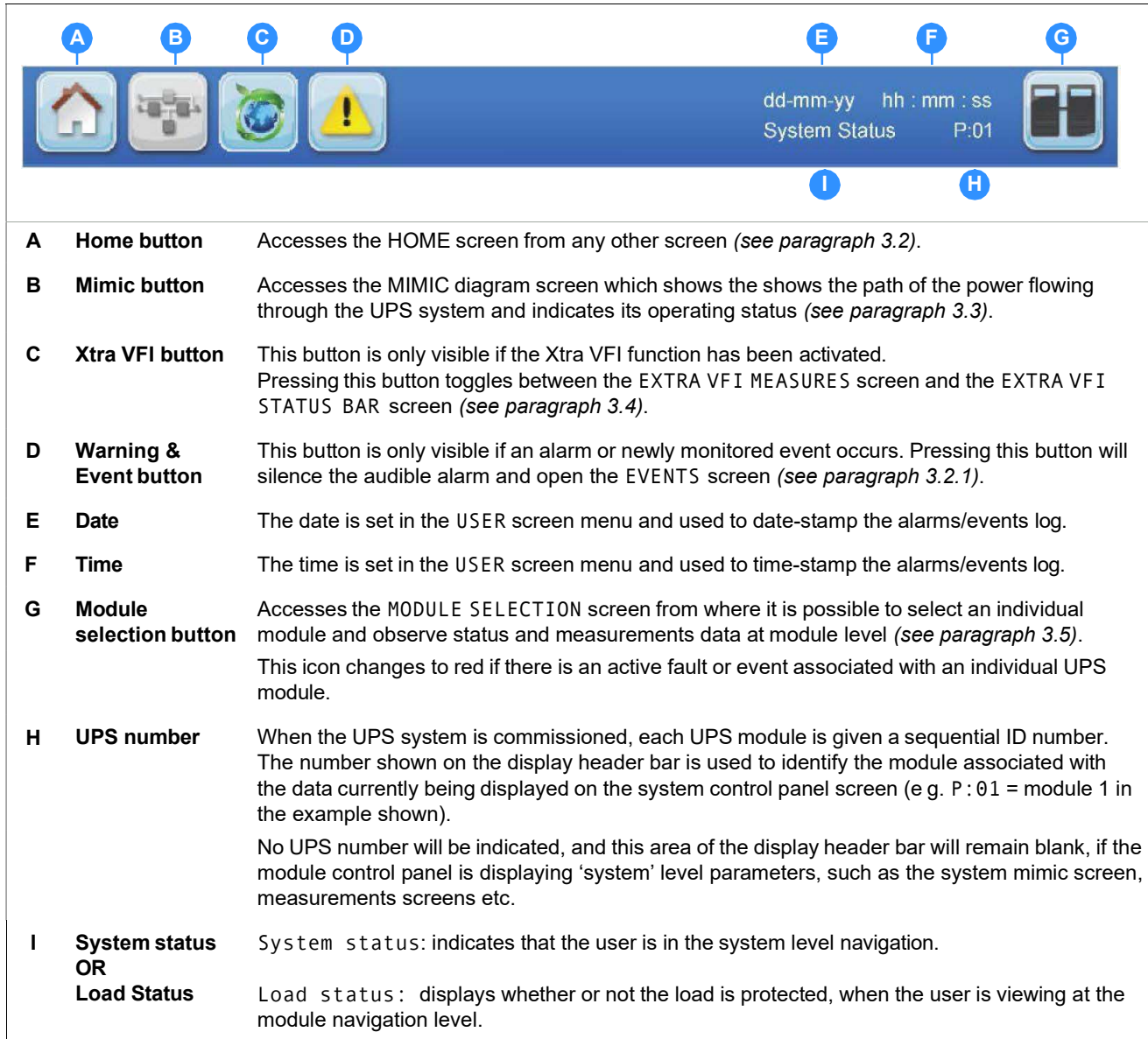
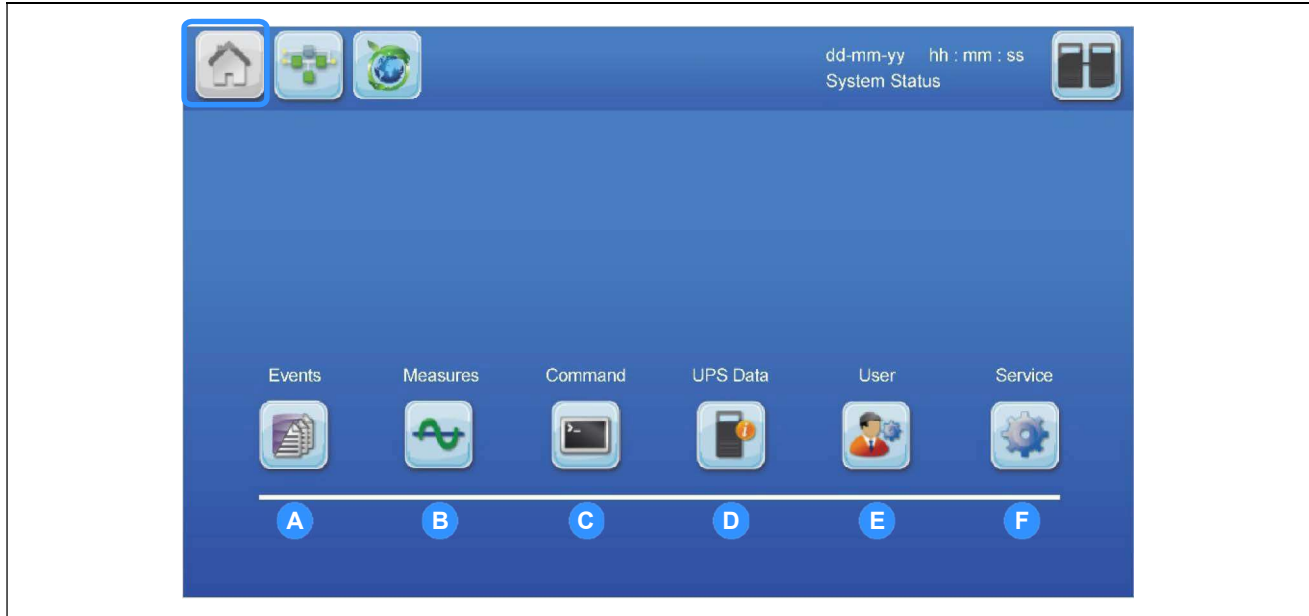

**Figure 3.2 Display header bar**

A detailed description of each of the screens accessed by each of the buttons on the Display Header Bar is provided on the following pages.

### 3.2 HOME screen

The HOME screen is accessed by pressing the Home icon on the display header bar. At the bottom of this screen are six touch-sensitive buttons that provide access to various monitoring, control and set-up function screens.



<b>A</b>	<b>Events</b>	Displays a list of recently occurred events with date, time, event name, description and sequential ID number. The Events are described in paragraph 3.2.1.
<b>B</b>	<b>Measures</b>	This item displays the full set of measurements for each of the UPS functional blocks, as described in paragraph 3.2.2.
<b>C</b>	<b>Command</b>	This menu enables the user to change the UPS operating mode between LOAD ON INVERTER and LOAD ON BYPASS ( <i>see paragraph 3.2.3</i> ).
<b>D</b>	<b>UPS Data</b>	Provides non-editable information regarding the UPS module identity ( <i>see paragraph 3.2.3</i> ).
<b>E</b>	<b>User</b>	Enables setting the date and time, automatic battery test, etc, as described in paragraph 3.2.5.
<b>F</b>	<b>Service</b>	This area is intended to be used by a trained service engineer only and is password protected

Figure 3.3 HOME screen

#### 3.2.1 Events

Pressing the HOME screen Events button (or display header bar Warning button, when visible) will open the EVENTS screen which displays a time/date-stamped list of events in chronological order.

Each event line identifies the affected UPS module (Id), together with an event Status and number (Ev.) as well as a textual event description. The UP/DOWN arrows on the top right of the screen allow you to scroll through the history.

Note that changes to the system/module operation are registered as events and not just fault occurrences.

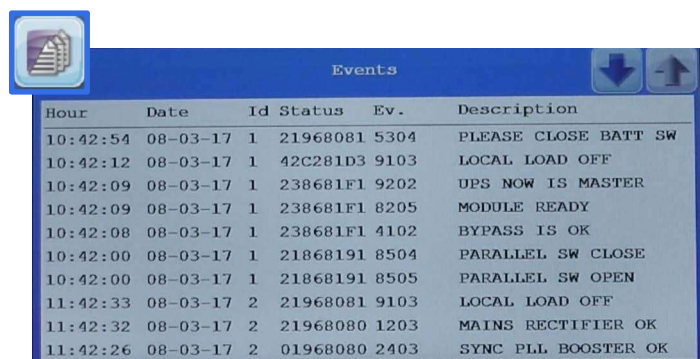

Figure 3.4 EVENTS screen

### 3.2.2 Measures

Pressing the HOME screen Measures button will open the MEASURES screen shown here, which displays the working values of various UPS, Battery and Xtra VFI operating parameters.

You can select the parameters to be displayed by pressing the UPS Meas, Battery and Xtra VFI buttons on the left side of the screen.

#### UPS Measures (Figure 3.5)

Two screens are required to show all the UPS parameter measurements; these can be selected using the UP/DOWN arrows on the top right of the screen.



Figure 3.5 MEASURES screen (UPS)

#### Battery Measures (Figure 3.6)

In a multi-battery installation such as a large UPS system where the UPS modules are connected to a number of separate batteries, the Battery MEASURES screen monitors every battery installation and indicates the 'worst-case' scenario.

For example, the screen will show the highest temperature, greatest discharge current and lowest capacity of any battery installation.

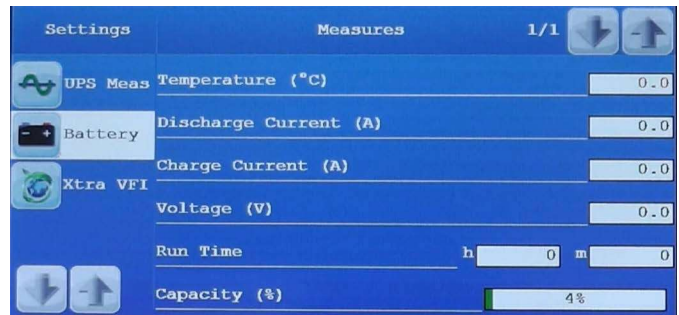

Figure 3.6 MEASURES screen (Battery)

#### Xtra VFI Measures (Figure 3.7)

The XTRA VFI screen show the Xtra VFI operating status and indicates the number of inverters that are operating or on 'standby'. It also indicates the energy saving attributed to the Xtra VFI operation.

The Total Saved Energy [kWh] indication is cumulative, but the Saved Energy [kWh] value can be reset by pressing the Reset button located at the lower right corner of the screen. This allows you to measure the amount of save energy over a given period, between resets.

Note that this screen can also be accessed by pressing the Xtra VFI button on the display header bar when the XTRA VFI STATUS BAR screen is displayed.

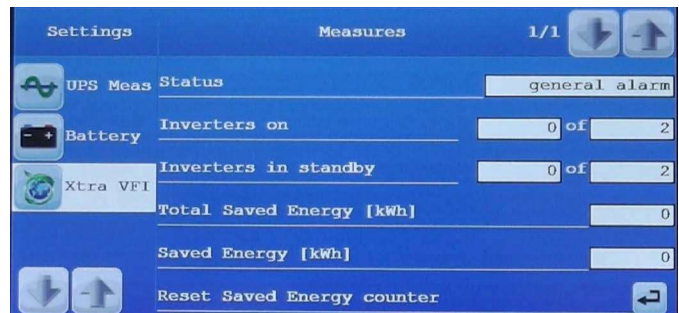

Figure 3.7 MEASURES screen (Xtra VFI)

### Measures summary

<b>UPS Measurements</b>	Output Voltage (V) Output Power (%) Apparent Power (kVA) Bypass Frequency (Hz)	Output Current (A) Active Power (kW) Inverter Voltage (V) Rectifier Voltage (V)	Output Frequency (Hz) Reactive Power (kVAr) Bypass Voltage (V) Bypass Temperature (°C)
<b>Battery Measurements</b>	Temperature (°C) Voltage (V)	Discharge Current (A) Run Time	Charge Current (A) Capacity(%)
<b>Xtra VFI Measurements</b>	Status Total Saved Energy (kWh)	Inverters on (operating) Saved Energy (kWh)	Inverters in standby Reset (Saved Energy Counter)

### 3.2.3 Commands

Pressing the HOME screen Commands button will open the COMMANDS screen shown here.

This screen allows you to manually transfer the load between Inverter and bypass by pressing the appropriate button on the right side of the screen.

When the selected transfer has taken place, the screen will change to show the MIMIC screen to show that the transfer has been executed (see paragraph 3.3).

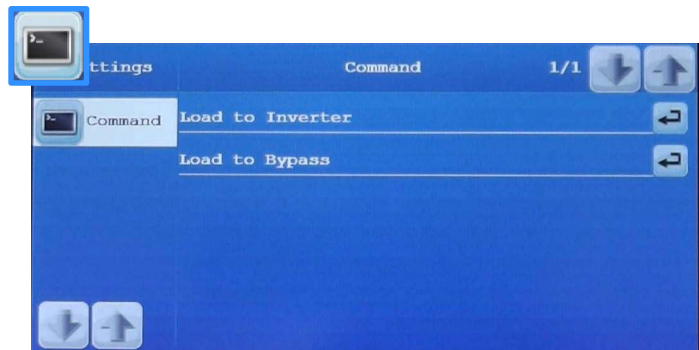

Figure 3.8 COMMANDS screen

### 3.2.4 UPS Data

Pressing the HOME screen UPS Data button will open the UPS DATA screen shown here. This screen displays the UPS serial number and other system data entered by the commissioning engineer.

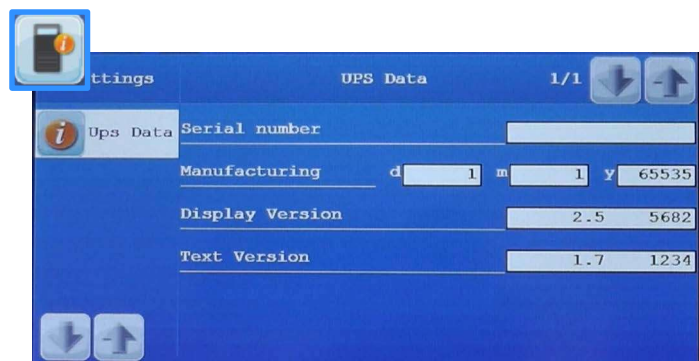

Figure 3.9 UPS DATA screen

### 3.2.5 User

Pressing the HOME screen User button will open the USER screen shown here. This screen allows you to select the system control panel language, set the screen contrast, and turn off/on the sound associated with operating the touch buttons.

*Note: The screen will be calibrated by the commissioning engineer if necessary and we strongly recommend that you do not touch the Display Calibration button.*



Figure 3.10 USER screen

### 3.3 MIMIC screen

The MIMIC screen is the default screen shown on the system control panel during normal operation. It shows the path of the power flowing through the UPS system and provides basic input, battery and output metering.

This screen can be accessed by pressing the Mimic button on the display header bar or by selecting a particular UPS Module icon button on the MODULE SELECTION screen (see paragraph 3.5).

When you access the MIMIC screen from the HOME screen the mimic diagram and on-screen metering relate to the UPS 'system' as a whole; but when it is accessed from the MODULE SELECTION screen the mimic diagram relates directly to the selected module and no on-screen metering is shown.

*Note: When the screen is working at a 'module' level the module number is shown adjacent to the Module Selection button on the display header bar (e.g. P:01).*

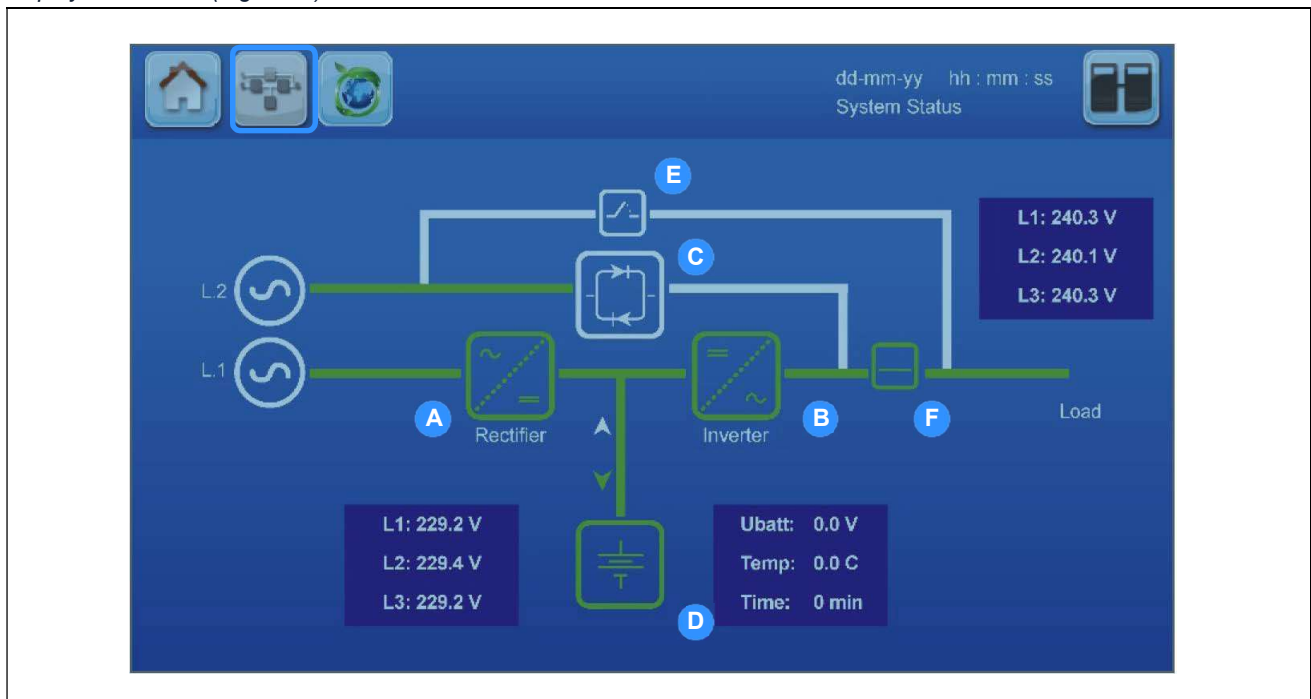

<b>A</b>	<b>Rectifier</b>	Green: Red:	The rectifier is turned on. The rectifier is switched off.
<b>B</b>	<b>Inverter</b>	Green: Red:	The inverter is turned on and supplying load power. The inverter is switched off.
<b>C</b>	<b>Static Bypass</b>	Green: White:	The load is connected to the bypass (or the system is operating in ECO-mode). The bypass is off.
<b>D</b>	<b>Battery</b>	Green: Yellow: Red:	Battery is charging or discharging. – the direction of flow is indicated by the adjacent green arrowheads. Battery low. Battery is in fault condition or is discharged.
<b>E</b>	<b>Maintenance Bypass Isolator IA1</b>	Yellow: White:	Load is on maintenance bypass (optional maintenance bypass switch closed) Maintenance bypass switch open.
<b>F</b>	<b>Parallel switch IA2</b>	Green: White:	Parallel switch is closed (Position ON). Parallel switch is opened (Position OFF).

**Figure 3.11 MIMIC screen (system level includes on-screen metering)**

### 3.3.1 MIMIC screen indications

The status of the major UPS power blocks and power paths is colour-coded as follows:

<b>GREEN:</b>	ACTIVE – the power block is turned on and operational / the power path is live.
<b>WHITE:</b>	INACTIVE – the power block is functional but not currently in use (e.g. static bypass operational but not required so it is turned OFF) / the power path is available but not currently used
<b>YELLOW:</b>	WARNING – the UPS is operating on maintenance bypass
<b>RED:</b>	FAULT – the power block is faulty or turned off / the power path has lost its power source

Three meters are included on the mimic display screen to indicate the UPS input and output voltage, frequency and current. The displayed battery parameters include the battery voltage, temperature and remaining autonomy time.

Examples of the mimic displays for the major operating modes are shown below.

#### ON-INVERTER

This is the normal mimic indications for a (standard) On-Line UPS system.

1. The rectifier and inverter are working normally.
2. The battery is charging.
3. The parallel switch is closed and connecting the UPS output to the load.
4. The bypass line is live and available.

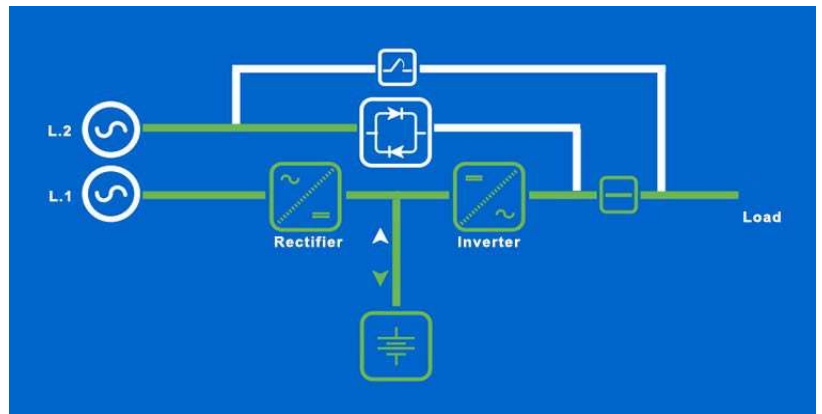

Figure 3.12 ON INVERTER mimic

#### ON-BATTERY

This mimic shows that the UPS is operating on battery due to the loss of mains power (L1).

1. The rectifier is turned off.
2. The battery is discharging.
3. The inverter is still operating and the providing power to the load.
4. In a split-bypass system the bypass line (L2) will be live if the bypass supply is still available, otherwise it will indicate a power loss (red) along with the rectifier mains input (L1).

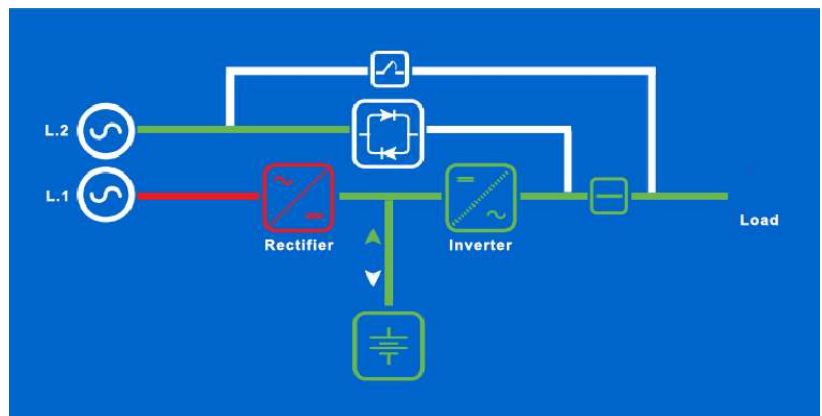

Figure 3.13 ON BATTERY mimic

### ON-BYPASS

This mimic indicates that the load is being supplied via the bypass line, and it is the normal indication if the system is operating in 'ECO' mode.

When the system is normally operating in 'on-inverter' mode, this state usually indicates that the load has either been manually transferred, transferred due to an output overload that has caused the inverter to shut down, or transferred due the loss of module redundancy.

If the transfer to bypass is due to an inverter fault, the inverter icon will be red.

1. The rectifier is working normally.
2. The battery is charging.
3. The inverter is turned off or shut down.
4. The parallel switch is closed and connecting the UPS output to the bypass supply (unprotected raw mains).

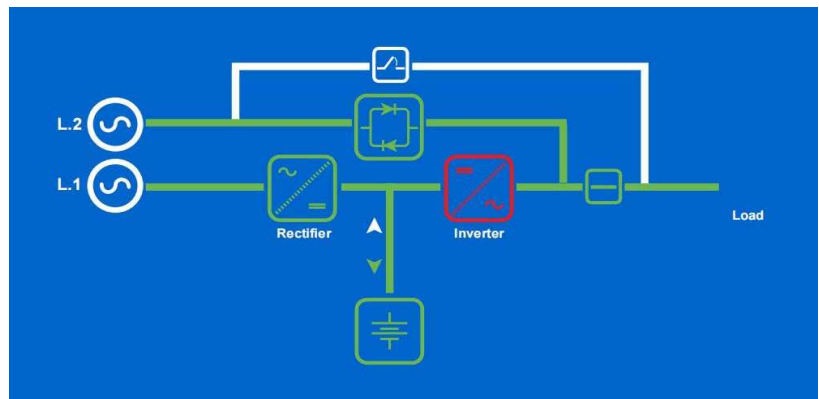
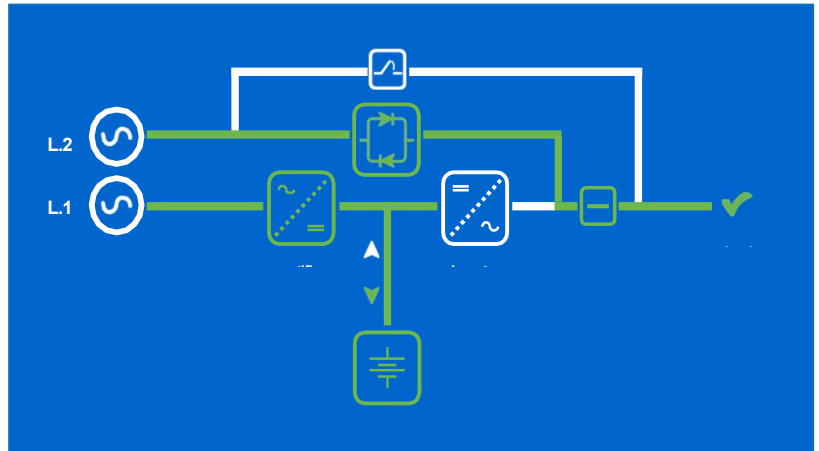

Figure 3.14 ON BYPASS mimic

### ON MAINTENANCE BYPASS

This mimic indicates that the (optional) maintenance bypass isolator is closed and the load is connected to the bypass supply through both the 'maintenance' and 'static' bypass lines in parallel.

1. The rectifier is working normally.
2. The battery is charging.
3. The Inverter is turned OFF.
4. The parallel switch is shown closed. At the module level, if the module's output isolator is now opened, the UPS module is totally isolated from the UPS output and can be replaced or serviced without affecting the rest of the UPS system.

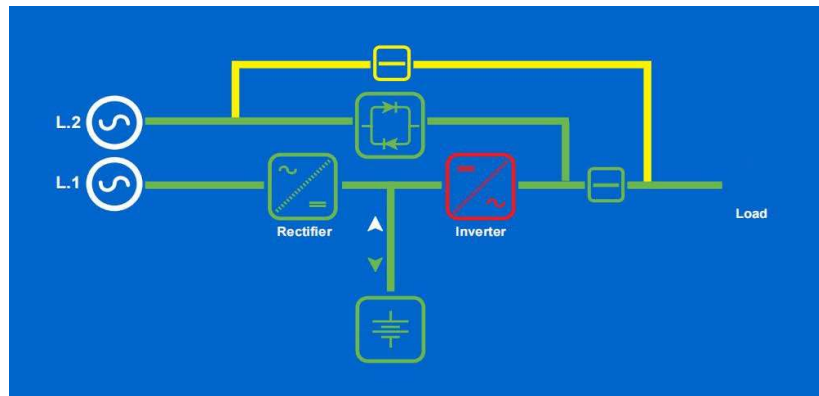

Figure 3.15 ON MAINTENANCE BYPASS mimic

### 3.3.2 Metering from the MIMIC screen

On the MIMIC screen, the icons representing the rectifier, inverter, static bypass and battery power blocks also act as touch-sensitive buttons which, when pressed, open a version of the MEASURES screens related to the selected power block. This is applicable when the mimic is displaying both 'system' or 'module' level data.

*Note: The screens that are accessed through this path use the same data sources as the MEASURES screens described earlier, but the displayed content is organised differently.*

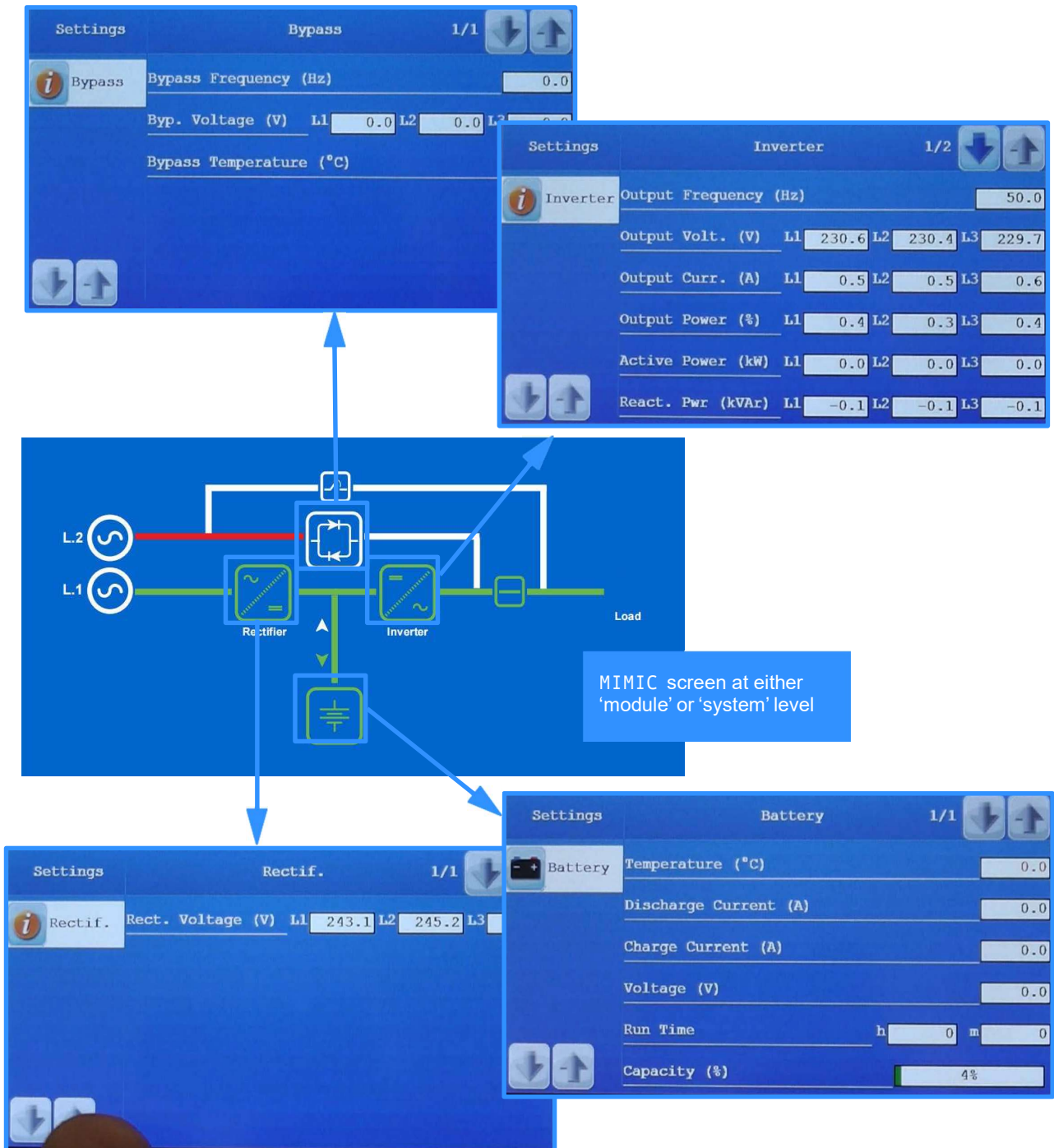
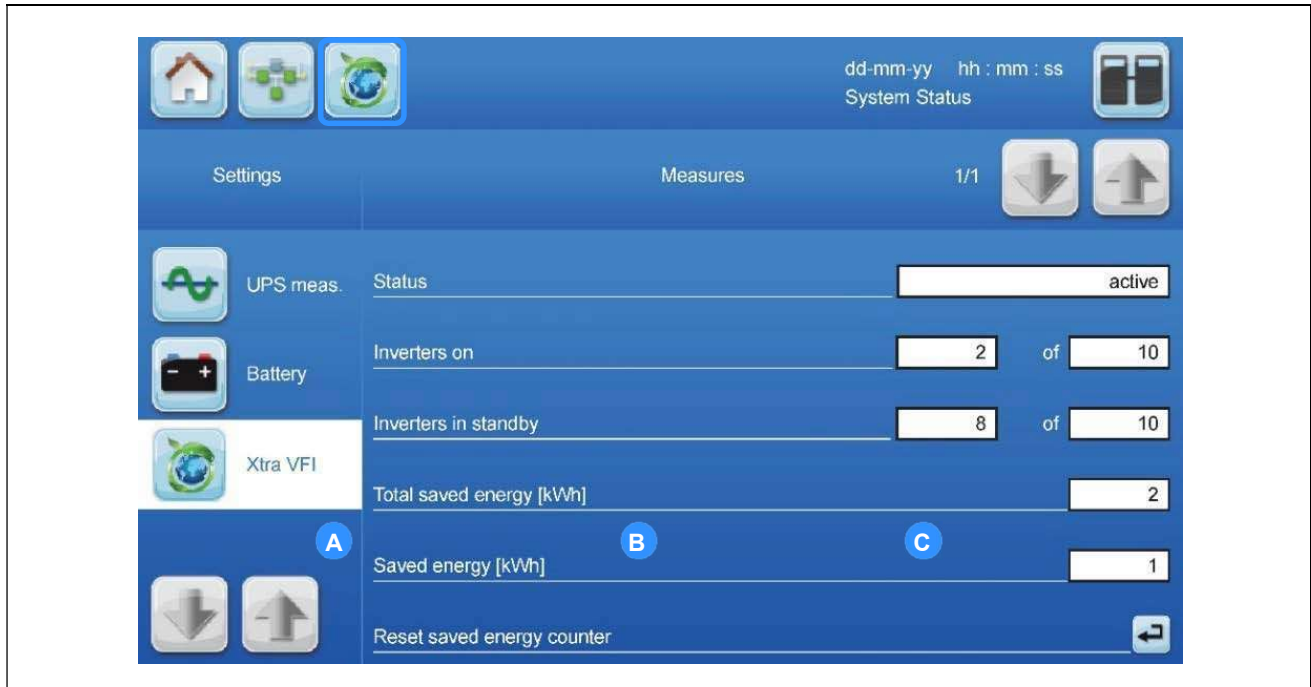

Figure 3.16 MIMIC Metering

### 3.4 XTRA VFI screen(s)



<b>A</b>	<b>Load</b>	The dark green area of the status bar indicates the applied load as a percentage of the UPS system rated capacity.
<b>B</b>	<b>Active</b>	The light green area of the status bar indicates the remaining capacity of the active inverters – i.e. those inverters that are turned on, and operating under the control of the Xtra VFI function.
<b>C</b>	<b>Standby</b>	The light blue area of the status bar indicates the capacity of the modules operating on standby that can be called upon by the Xtra VFI function if required to support any load increase.

**Figure 3.17 Xtra VFI status bar screen**

The XTRA VFI STATUS BAR screen can be accessed by pressing the Xtra VFI button on the display header bar (only visible if the Xtra VFI function is enabled).

There are two screens related to the Xtra VFI function:

- The XTRA VFI STATUS BAR screen, shown above, provides a bar chart representation of the Xtra VFI operation in terms of relative capacity, remaining capacity from the active inverters and the additional capacity available from the inverters currently operating on standby.
- The 'XTRA VFI MEASURES' screen, described in detail on page 25, provides numerical data concerning the module status and saved energy.

You can cycle between these two screens by pressing the Xtra VFI button on the display header bar. To exit these screens you must press a different button on the display header bar or select another function in the MEASURES screen.

### 3.5 MODULE SELECTION screen

The module selection screen, shown below, is accessed by pressing the Module Selection button on the display header bar. On opening, the MODULE SELECTION screen displays an icon for each UPS module connected to the system and immediately indicates its operational status by means of its displayed colour. The UPS modules, which are identified numerically by the ID number entered into the module's configuration set-up during commissioning, are shown in vertical columns representing each UPS cabinet. The diagram below identifies five modules fitted to a single cabinet, with the bottom module assigned an ID of 01. A maximum six-cabinet system containing 30 UPS modules is shown in Figure 3.19.

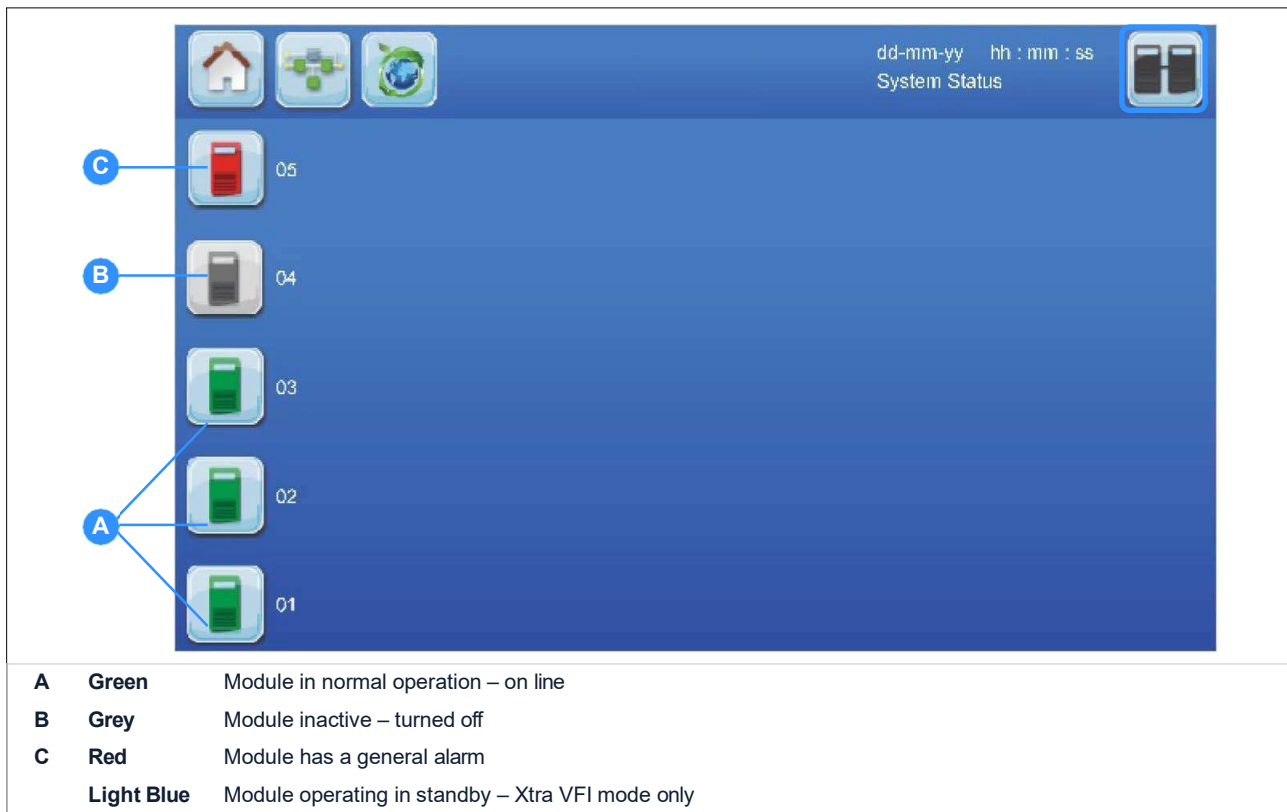

Figure 3.18 Module selection display screen

Note that if a UPS cabinet is not fully populated, the numbering protocol will not skip the missing module(s). For example, if there are only four modules fitted in the first two cabinets there will be no icons shown in the [05] and [10] slots, but the numbering sequence for cabinets 2 and 3 will still begin with [06] and [15].

If you press one of the touch-sensitive icon buttons the MIMIC screen will open which allows you to observe the operation and metering for the selected module, as described in paragraph 3.3.



Figure 3.19 30-Module system

## 4. Installation

### 4.1 Introduction

This chapter contains essential information concerning the safe unpacking, positioning, installing and cabling of the Rehiko PW 9500DPA UPS system.



**Key Point:** If you are installing an external battery cabinet supplied by Rehiko you should refer to the manual that is provided with the cabinet for installation instructions.



**WARNING:** All cabling operations must be supervised by an authorised electrician or other suitably qualified person. All installation procedures must be carried out in strict accordance with the instructions contained in this manual. Rehiko will take no responsibility for any personal injury or material damage caused by the incorrect installation, cabling or operation of this product.



**WARNING:** Once the UPS equipment is installed it must be commissioned by an engineer approved by Rehiko **before it is powered-up**. Rehiko will take no responsibility for any personal injury or material damage caused by the application of electrical power to this equipment before it has been fully commissioned.

### 4.2 Taking receipt of the UPS

The UPS and accessories are delivered on a purpose-designed pallet that is easy to move with a forklift or a pallet jack.



**CAUTION:** Observe the following precautions when off-loading and moving the UPS:

- Always keep the packages in an upright position.
- Do not drop the equipment.
- Do not stack the pallets.

Depending on the method of shipping, the UPS is packed in a cardboard or wooden container designed to protect it from mechanical and environmental damage. Further protection is provided by wrapping the equipment with a plastic sheet.

Before you accept the shipment ensure that the received package(s) correspond to the description shown in the delivery documentation. Note that some ordered optional equipment packages might be shipped inside the UPS cabinet.

Carefully examine the packing container for signs of physical damage. The external 'Tip&Tel' ("FRAGILE" and "ARROW") indicators should be intact if the equipment has been transported in an upright position.

#### 4.2.1 Reporting transportation damage



**WARNING:** If the Tip&Tell indicators indicate that the UPS has been tilted in transit DO NOT connect the UPS to the mains electricity supply.

If the 'Tip&Tel' indicators are ruptured or there are other signs of suspected transportation damage you must inform the carrier and Rehiko immediately.

Other claims for shipping damage must be filed immediately when found, and the carrier must be informed of ALL claims within seven days of receipt of the equipment. If the equipment is to be stored for longer than seven days before it is installed, you should unpack it and inspect it for signs of internal damage before you put it into storage. Note that some optional equipment packages might be shipped inside the UPS cabinet and these too should be checked for damage.

If the equipment is damaged you should store the packing materials for further investigation

## 4.2.2 Local transportation

When you transport the UPS equipment after it has been off-loaded please observe the following precautions.



**CAUTION:** Local transportation:

- When moving the UPS cabinet using a forklift or pallet jack, insert the lifting equipment forks into the front and rear shipping brackets to lift the cabinet securely and prevent it from toppling over.
- Do not at any time tilt the cabinet by more than 10° from vertical.



**WARNING:** Potential dangers:

- If the equipment cabinet is tilted by more than 10° it could cause internal damage. If tilting occurs do not connect the UPS to the mains electrical supply.
- The weight cabinet can cause serious personal injury and/or structural damage to the surrounding area if dropped in transit. Always take extreme care when moving the equipment.

## 4.2.3 Storage

If you plan to store the UPS prior to its installation it should be kept (preferably in its shipping packaging) in a clean, dry environment with a temperature between -25°C to +70°C and RH <90%. If the storage period is likely to exceed seven days the packaging should be removed and the UPS inspected for shipping damage before it is placed into storage. If there is no apparent damage you should refit the packaging or cover the UPS with a dust-cover to prevent the ingress of dust and dirt.

## 4.3 Unpacking the equipment



**WARNING:** The UPS cabinet, battery cabinet and battery packages are heavy and may tip during unpacking unless the unpacking instructions are not followed closely.

If the shipment is received in good order (i.e. the 'tip & tell' "FRAGILE" and "ARROW" indicators on the packing container are intact) then unpack the UPS as follows:



Figure 4.1 UPS Cabinet packaging

1. If the cabinet is shipped inside a wooden case, remove the screws at the base and sides of the case then carefully remove the case from the from the package.
2. Remove the plastic sheeting covering the UPS.
3. Remove the external cabinet protection pieces (strengthened cardboard fillets, polystyrene foam etc.).
4. Remove the anchor bolts securing the cabinet to the pallet then lift and remove the cabinet from the pallet.
5. Retain the packaging materials for future shipment of the UPS.
6. Examine the cabinet for any sign of damage and notify your supplier immediately if any damage is found.
7. Open the cabinet door and verify that the UPS rating specifications on the nameplate located inside the door match the order specification.
8. Remove any accessories packages that are shipped inside the cabinet.
9. Remove any internal protective packaging.
10. Ensure that all the UPS modules are correctly and securely fitted in their rack compartments.
11. Ensure that a protection cover is fitted to the front of any unpopulated UPS module rack compartment.

### Batteries



**CAUTION:** The UPS batteries must ALWAYS be installed by the commissioning engineer.

If the batteries are shipped in a separate package they should remain in their packing until required by the Rehiko service engineer when the system is commissioned.

Optimum battery life will be obtained if the batteries are stored and operated at a temperature of 20°C.



**WARNING:** If the UPS is delivered without batteries, Rehiko will not accept responsibility for any damage or malfunctioning caused to the UPS by the incorrect storage, installation or connection of batteries carried out by third parties.

## 4.4 Installation planning (environmental & mechanical)

### 4.4.1 Environmental considerations

A certain amount of pre-planning will help provide a trouble-free installation process. You should consider the following guidelines when planning a suitable UPS location and operating environment.

1. The route to the installation location must allow the equipment to be transported in an upright position.
2. The floor at the proposed installation site and en-route from the off-loading point must be able to safely support the weight of the UPS and battery equipment, plus fork lift or trolley jack during transit.
3. The UPS cabinet requires space to bottom/front, top and back to enable cooling airflow (see below).
4. A minimum clearance of 300mm must be provided at the back of the cabinet to provide adequate ventilation. A clearance of 400mm should also be provided at the top of the cabinet if the available free passage of cooling airflow leaving the back of the cabinet is insufficient to dissipate the generated heat.
5. Access to all parts of the UPS required for maintenance, servicing and user operation can be gained from the front of the cabinet and require a minimum front clearance of 1500mm (see the following 'key point').



**Key Point:** The UPS modules are large and heavy, and require two persons to install them manually. A purpose-designed lifting trolley is available which enables the UPS modules to be installed by one person; however, where used, the front clearance must be a minimum of 2500mm.

*Note: The cabinet left door must be opened by 135° in order to remove/fit the UPS modules, so the left side of the cabinet cannot be positioned directly against a projecting wall (see Figure 4.2).*

1. A battery temperature of 20°C is necessary to achieve the recommended battery life span. The cooling air entering the UPS modules must not exceed +40°C.
2. The floor material should be non-flammable and strong enough to support the heavy load.
3. In summary, the UPS should be located where:
  - a. Humidity (< 95%) and temperature is 0~20°C. Battery temperature of 20°C to maximise battery life.
  - b. Fire protection standards are respected.
  - c. Cabling can be performed easily.
  - d. A minimum 1500mm front accessibility is available for service or periodic maintenance.
  - e. Adequate cooling air flow is available.
  - f. The air conditioning system can provide a sufficient amount of air cooling to keep the room at, or below, the maximum desired temperature.
  - g. No dust or corrosive/explosive gases are present.
  - h. The location is vibration free.

### 4.4.2 UPS cabinet installation

1. If the UPS is located in bayed enclosures, you must install partition walls.
2. Before you move the UPS to its final position carry out any necessary pre-installation cabling (power and control cables) to ensure that full cable access is available once the UPS is placed in-situ. Top or bottom cable access is possible, or a combination of the two.

### Clearances

Cooling air enters the front and bottom of the UPS cabinet and is extracted by ventilation fans mounted on the cabinet rear. If the UPS cabinet is installed immediately adjacent to another cabinet, battery enclosure or wall, a minimum clearance of 300mm is required at the rear of the cabinet to permit sufficient cooling air flow.

The UPS cabinet does not require any side clearance for ventilation or service access, so it can be installed immediately alongside another UPS cabinet or battery cabinet to form an equipment suite. Ideally, you should install the external battery cabinet immediately adjacent to the UPS cabinet or as close to it as possible.

*Note: If you install the recommended external battery cabinet or battery rack supplied by Rehlko the battery cabinet itself does not require any side or rear clearance.*

All UPS cabling, maintenance and servicing procedures can be carried out from the front of the cabinet, and a front clearance of at least 1500mm should be provided to enable component replacement.



**Key Point:** When installing the UPS cabinet next to an external battery cabinet or battery rack, the battery cabinet/rack might require more than 1500mm front clearance which must be taken into consideration when installing a cabinet suite.



**Key Point:** The UPS door must be fully opened (to approximately 135°) to enable some major component to be extracted from the cabinet. If the cabinet is positioned against a wall that protrudes in front of the cabinet you must allow adequate, additional side clearance. See the clearance diagram for details.

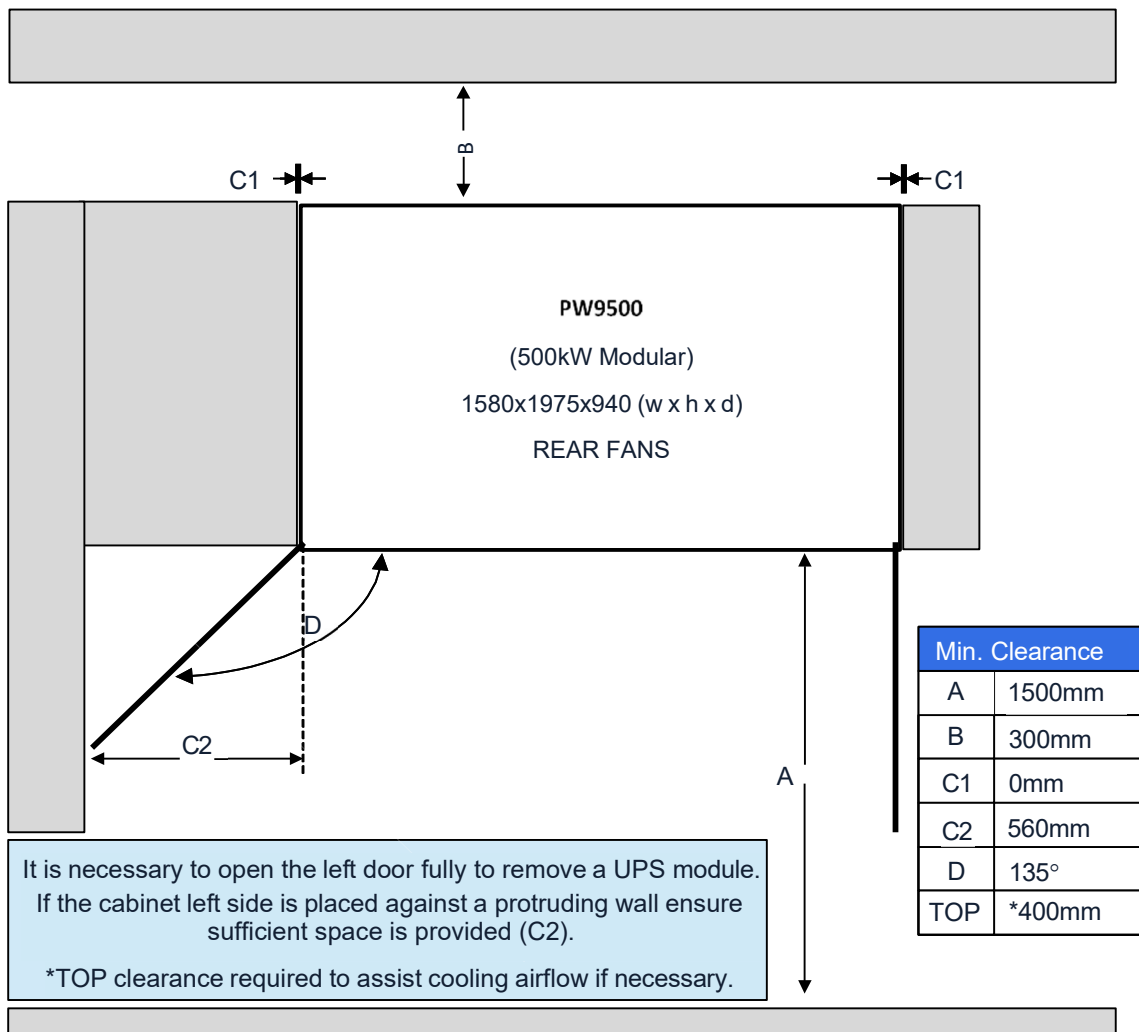

Figure 4.2 Clearances

### 4.4.3 Battery cabinet installation

We recommend that where possible the battery is contained in a purpose-designed cabinet installed immediately adjacent to the UPS cabinet. It can be positioned on either side of the UPS cabinet but we recommended that it is installed on the right hand side to minimise the length of the interconnecting DC cables.

If the batteries are to be mounted on external battery racks, rather than cabinet mounted, the battery must be sized to take into account the voltage drop between the battery installation and UPS. Contact Rehlko for installation advice and support if necessary.

## 4.5 Planning the installation (cabling considerations)

### 4.5.1 General requirements

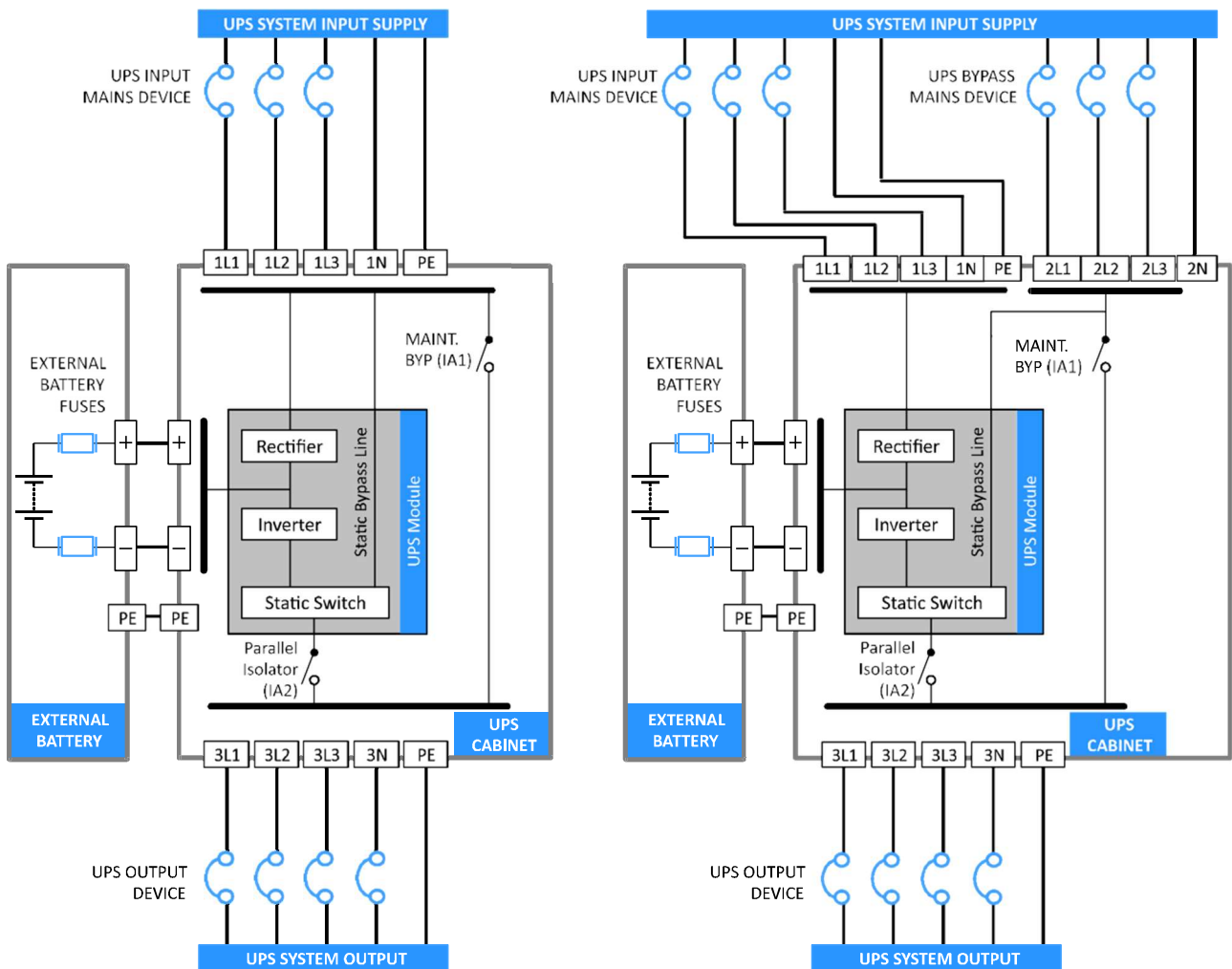

**Figure 4.3** Input/output power connections for single feed and dual feed installations

The UPS cabinet can be designed for a single input feed, where the UPS mains input supply is connected internally to the UPS bypass terminals, or for a dual feed input where the UPS bypass circuit is connected to a dedicated mains supply. The two designs are shown in Figure 4.3. Note that the input configuration is selected when placing the order for the UPS system and it is not possible to change the configuration on site.

It is the customer's responsibility to design and install the UPS supply and distribution circuits and provide the external fuses, isolators and cables required to connect the UPS input and output power supplies, and external battery. The information provided in this section should assist in the planning and preparation of the UPS power cabling.

As shown in Figure 4.3, the UPS input mains and bypass mains inputs should be connected to the UPS system input supply via a circuit breaker or fused device. The input device provides overload protection for the UPS and a means of isolating the UPS from the utility mains supply.

Similarly, the UPS output should be connected to the load equipment via a suitably protected UPS system output panel.

The external battery installation requires fuses fitted in the battery positive, negative, and mid-point (neutral) feeds, as shown in Figure 4.3. Rehlko can supply a matching battery cabinet containing the necessary fuses and switchgear.

#### 4.5.2 Parallel cabinet cabling recommendations

In a parallel cabinet installation all the UPS cabinets must be supplied from the same mains power source and the cables from the UPS input supply panel to each cabinet should be of equal length. Similarly, the cables connected to the UPS system output panel should be of equal length as shown in Figure 4.4 – this helps to balance the load sharing between the cabinets.

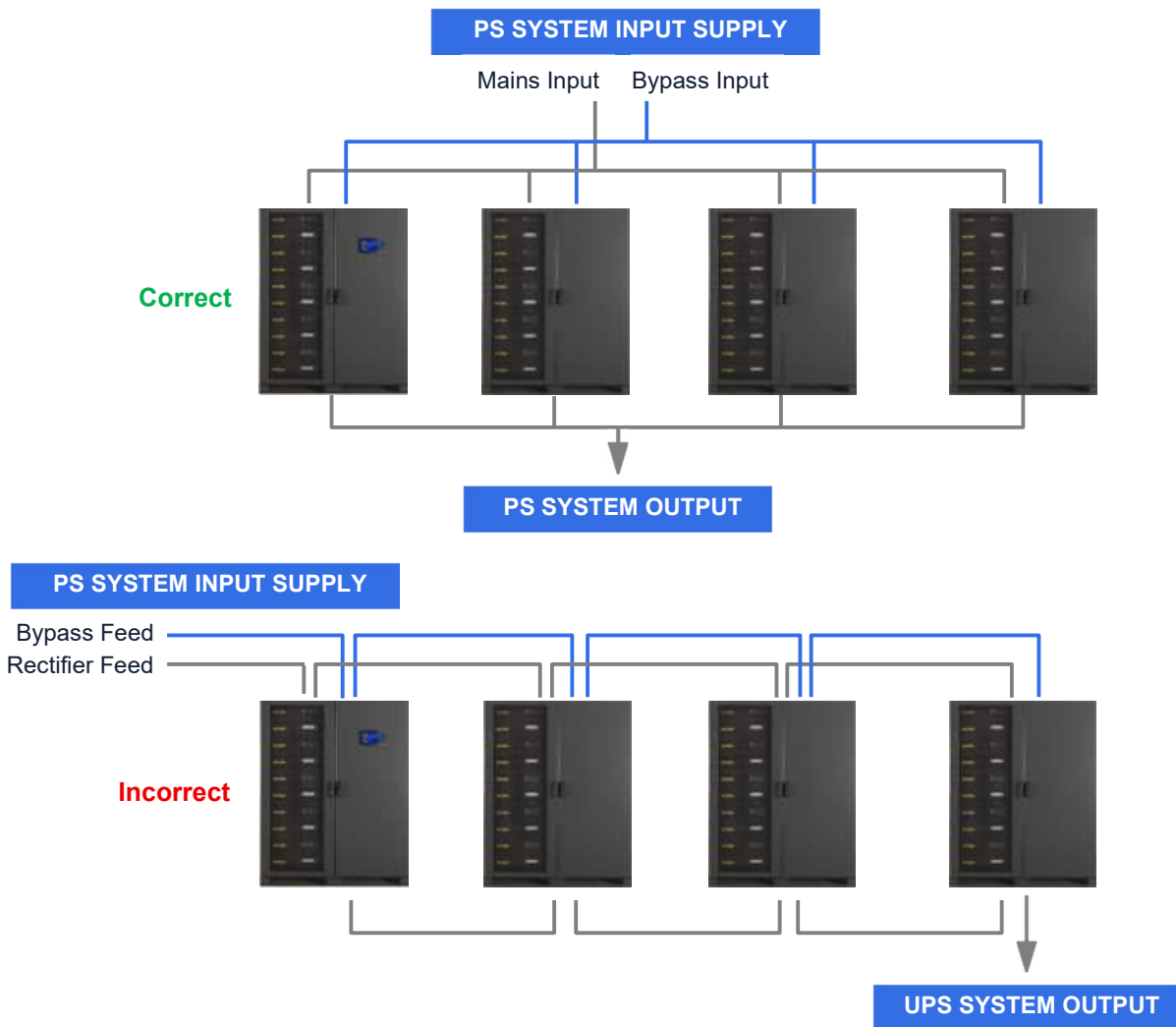

Figure 4.4 Parallel cabinet cabling recommendations

### Input neutral grounding

A permanently connected input neutral is required to enable the rectifier to operate correctly and allow the UPS to function properly when operating on battery.

The input neutral must also be grounded to permit correct operation when the UPS is running on battery.



**Key Point:** As the input neutral must be unswitched and connected to the UPS at all times. DO NOT use, a 4-pole input switch or isolator at the LV Distribution board on a TN-S system.

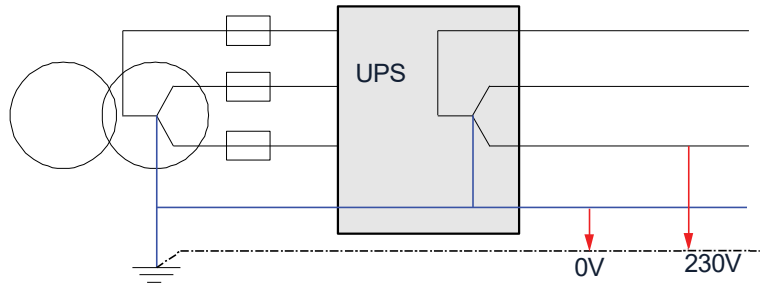

Figure 4.5 Permanent, grounded input neutral

### 4.5.3 External maintenance bypass switch

*Note: The maintenance bypass facility is an optional feature and may not be installed as part of your system.*

An external maintenance bypass is a required part of a multi-cabinet system but is optional in the case of a single cabinet installation.

The external bypass is bespoke to the installation but generally comprises three switches rated to carry the full system load and connected in a similar fashion to that shown in Figure 4.6.

The switches may be installed in a dedicated external Maintenance Bypass switch cabinet or included in an existing (or dedicated) switchgear panel. Rehlko can supply a range of external maintenance bypass solutions to suit all of its UPS systems.

*Note: If your load produces a large inrush current when it is initially turned on, we strongly recommend that you start the load equipment while the UPS is operating on the maintenance bypass during the UPS start-up procedure.*

#### Single UPS cabinet installation

An external maintenance bypass facility is not essential as part of a single cabinet installation as the internal maintenance bypass switch (IA1) is rated for the full cabinet output and it can be used to connect the load directly to the UPS bypass mains supply. However, when the load is connected via the internal maintenance bypass switch (IA1) the UPS input/bypass mains supply must be permanently available, so it is not possible to turn off these supplies to totally isolated the UPS cabinet (or UPS modules) while the internal maintenance bypass is in use.

This situation is overcome by adding an external maintenance bypass facility, similar to that shown in Figure 4.6, which can supply the load through the external BYPASS switch while allowing the UPS cabinet input and output power to be totally isolated by opening the external INPUT and OUTPUT switches.

#### Parallel UPS cabinet installation

When two, or more, UPS cabinets are connected as a parallel system the internal maintenance bypass switch (IA1) is removed from the cabinets and an external maintenance bypass facility is installed as an essential part of a parallel cabinet system.

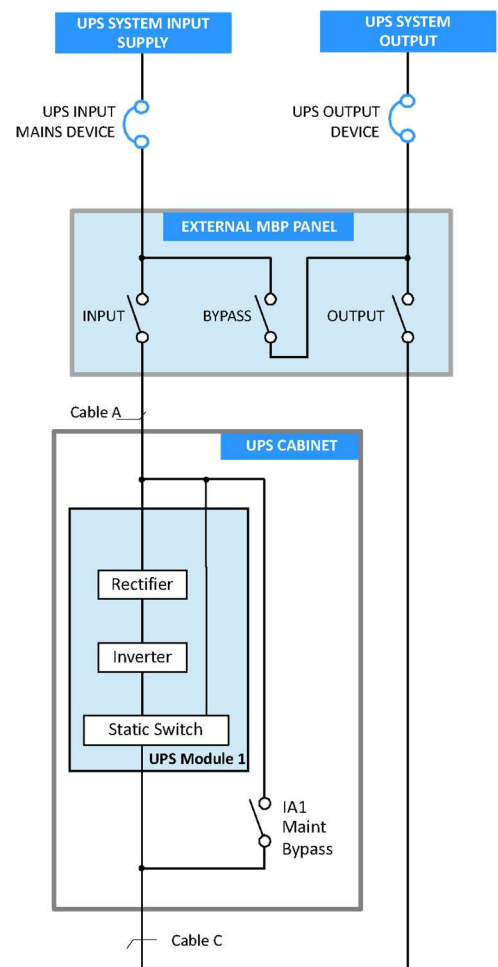

Figure 4.6 External Maintenance Bypass

#### 4.5.4 Cable sizing

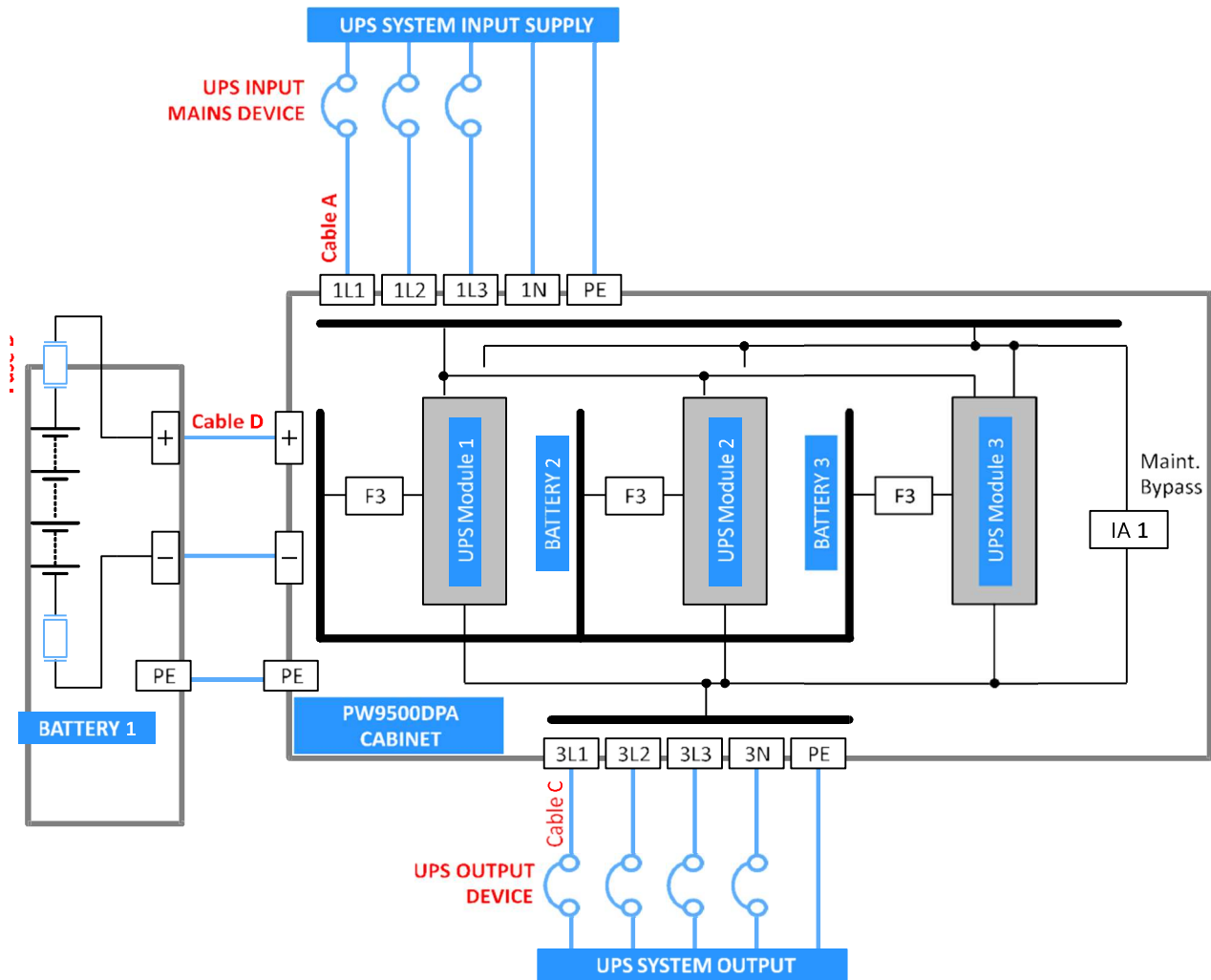

Figure 4.7 'Single feed' input block diagram

Figures 4.7 and 4.8 identify (in red) the power cables, fuses and other protective devices that must be provided by the customer for a single-feed and dual-feed connected installation respectively. The table below shows the maximum UPS input and output current for each set of cables together with the cable termination details. This is provided to assist the customer in selecting appropriately rated power cables and external switchgear.

*Note: These illustrations show a single set of DC cables (cable D) connected between the UPS and external battery cabinet. In a 'common battery' installation (as shown) the battery positive and negative cables are connected to the battery busbars which are located adjacent to the UPS input/output mains busbars. In a 'separate battery' installation the UPS battery busbars are removed and the individual battery positive and negative cables are connected directly to the modules' battery circuit breaker (F3).*



**Key Point:** We recommend M12 busbar connections are tightened to 42Nm. and M8 busbar connections tightened to 24 Nm.

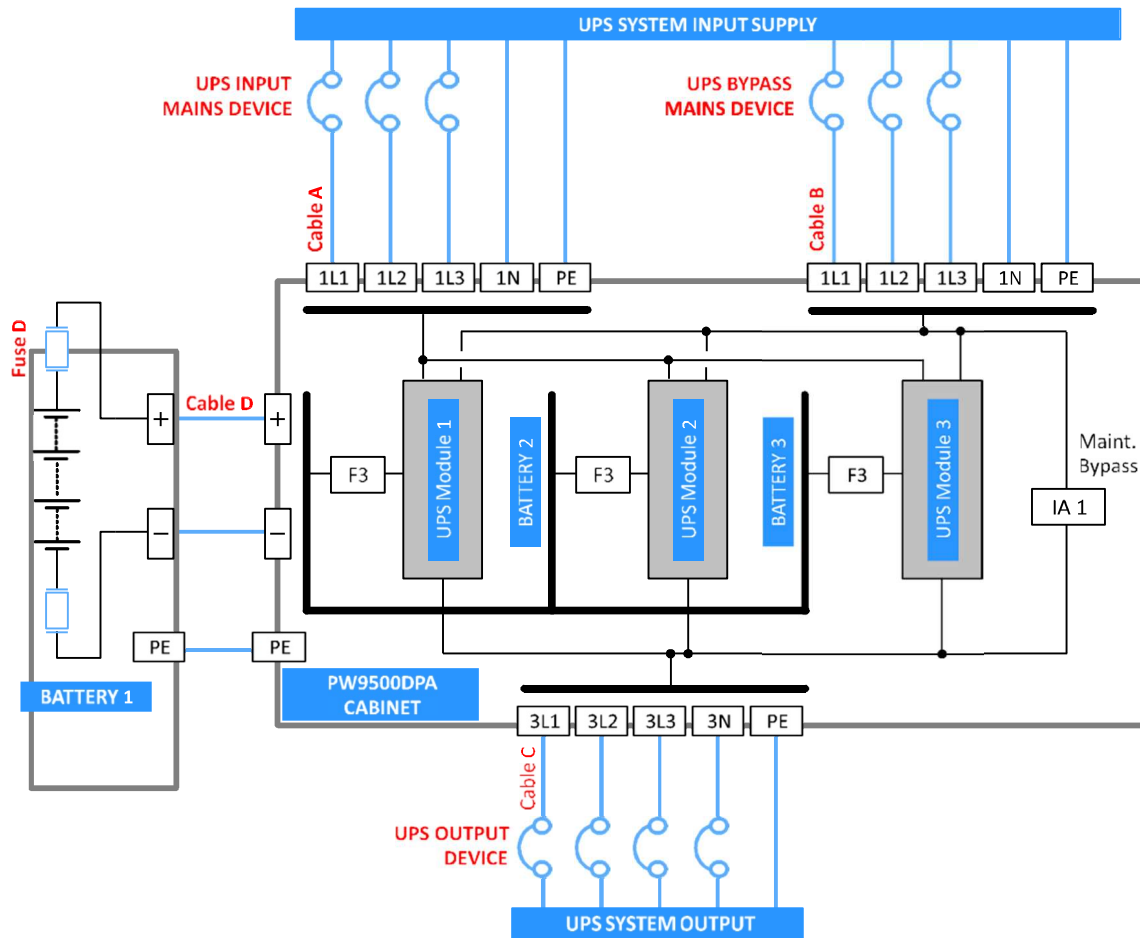

Figure 4.8 'Dual feed' input block diagram

400V / 230V						BATTERY		
INPUT MAINS (A)		BYPASS MAINS (B)		UPS OUTPUT (C)		PE	+ and -	N
Max. Current	Terminal	Max. Current	Terminal	Max. Current	Terminal	Terminal	Terminal	Terminal
835A	3x M12 (B) 1x M12 (N)(B) 1x M12 (PE)(B)	732A	3 x M12 (B) 1x M12 (PE)(B)	724A	3x M12 (B) 1x M12 (N)(B) 1x M12 (PE)(B)	Separate Batteries +/- M8 (B)	Separate Batteries M12 (N)(PE)(B)	Common Battery +/- M12 (B) Common M12 (N)(PE)(B)

(PE) = Protective Earth  
 (N) = Neutral  
 (B) = Busbar connections with indicated bolt size. Cable must be terminated with a suitable lug.  
 (T) = Screwed terminal block with indicated maximum cable c.s.a. Cable ends must be suitably prepared.



**Key Point:** This information is given for guidance only:

- Fuse and cable size recommendations are to IEC 60950-1:2001.
- All external fuses, isolators and power cables must be rated and installed in accordance with the prescribed IEC standards or local regulation – e.g. BS7671.
- External DC cables and battery fuses are bespoke to the installation.

#### 4.5.5 Cabling configurations

All the UPS power cables are connected to busbars located in the UPS right-hand cabinet and can enter the UPS from either the top or bottom. The busbar layout for top and bottom cable entry is shown in Figure 4.9.



**Key Point:** The position and design of the UPS power busbars is determined by the chosen cable entry configuration which must be specified when placing the UPS order. The power busbars cannot be repositioned on site. The manufacturer declines any responsibility for an inappropriate busbar arrangement once the order has been placed.

The UPS input and output AC cables can be specified as:

- Single input top entry – UPS Input mains cables and output cables enter the top of the UPS cabinet.
- Single input bottom entry – UPS Input mains and output cables enter the bottom of the UPS cabinet.
- Dual input top entry – UPS Input mains, bypass mains and output cables enter the top of the UPS cabinet.
- Dual input bottom entry – UPS Input mains, bypass mains and output cables enter the bottom of the UPS cabinet.

The UPS DC (battery) cables can be specified as:

- Common battery top entry – Battery cables enter the top of the cabinet and connected to the common battery busbar. Each module is connected to the common battery busbar via its battery breaker (F3).
- Common battery bottom entry – Battery cables enter the bottom of the cabinet and connected to the common battery busbar. Each module is connected to the common battery busbar via its battery breaker (F3).
- Separate battery top entry – Battery cables enter the top of the cabinet and are connected directly to the individual module battery breaker F3.
- Separate battery bottom entry – Battery cables enter the bottom of the cabinet and are connected directly to the individual module battery breaker F3.

A cable gland plate is included as standard but if you want to combine top and bottom cable entry (e.g. AC Top and DC bottom, or AC bottom and DC top) we recommend that you order an additional gland plate.

#### IMPORTANT NOTE

To make it easier to bend particularly heavy cables, extra space can be gained by using bottom cable entry but connecting the cables to the top entry busbars (and vice versa). This is also recommended where bus ducts are used, to provide the extra space needed to bend the flexible busbars onto the UPS busbars.

Please consult Rehiko for installation advice.

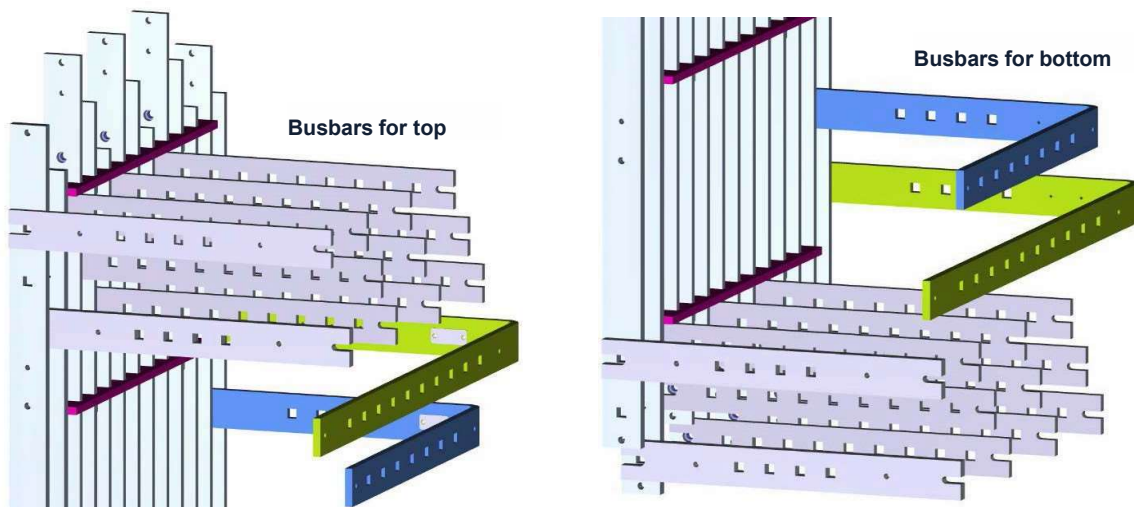
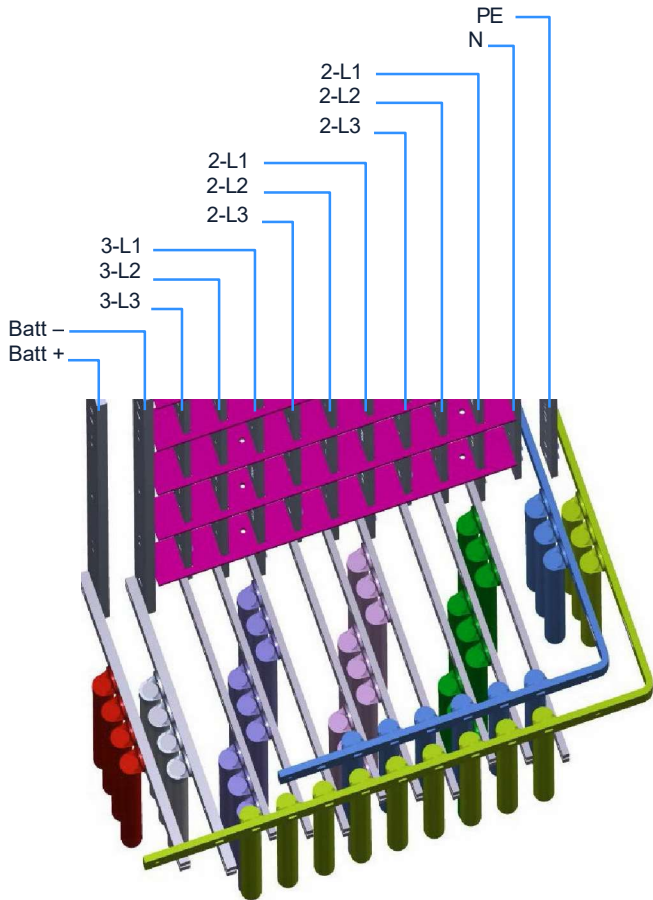
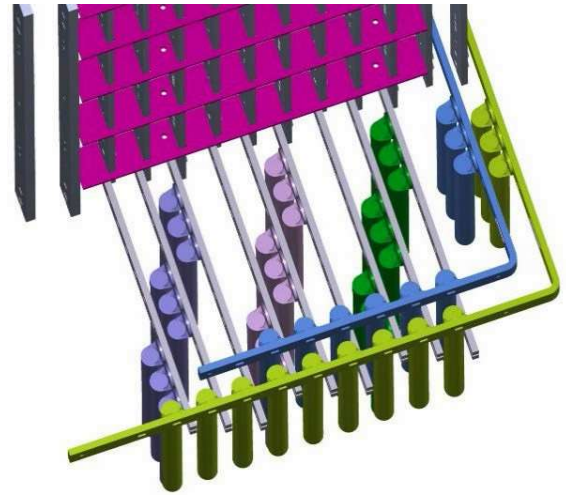

Figure 4.9 Alternative Top and Bottom entry busbar arrangement

#### 4.5.6 Power cable terminations



Bottom cable entry with common batteries.



Bottom cable entry with separate batteries.

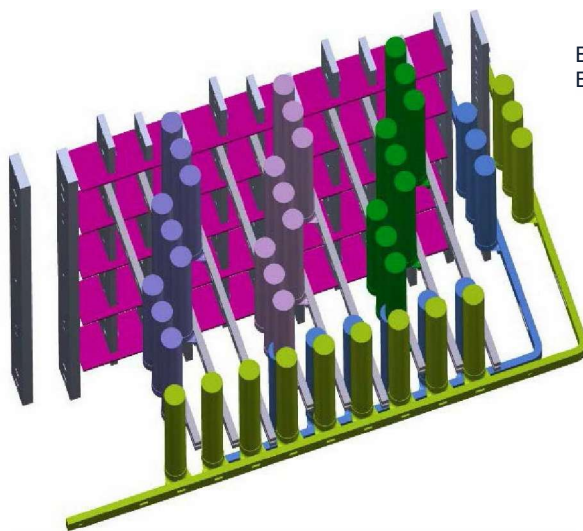

Top cable entry with separate batteries.

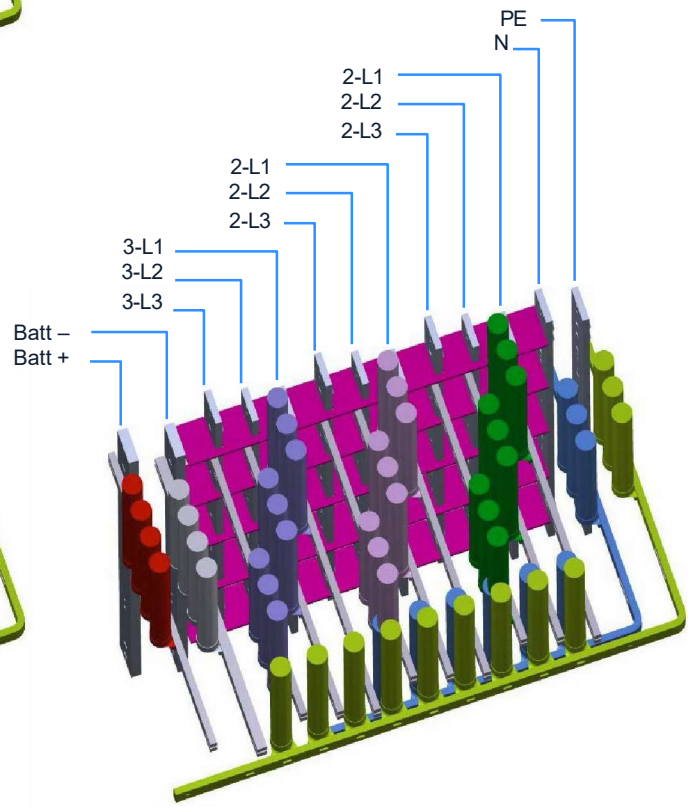

Top cable entry with common batteries.

Figure 4.10 Top and Bottom cable entry options

**Bottom cable entry**

Shows bottom-entry power busbars and the routing for the separate battery cables which are connected to the battery circuit breakers (F3).

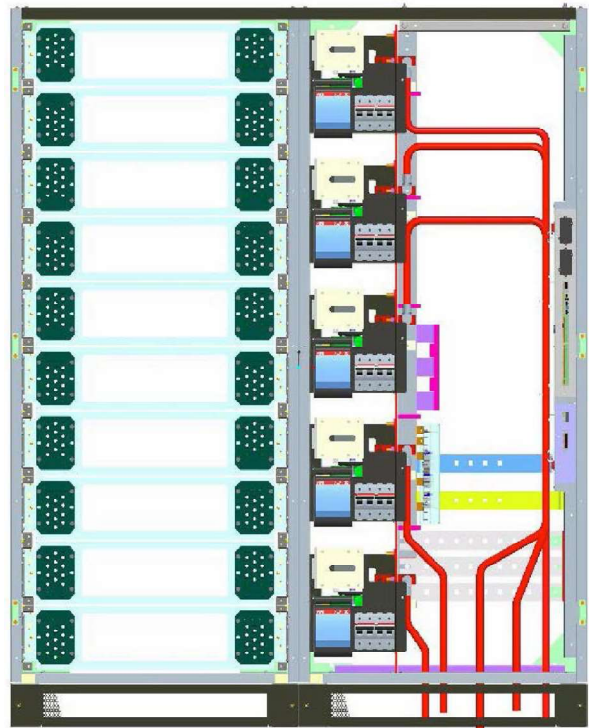

**Top cable entry**

Shows top-entry power busbars and the routing for the separate battery cables which are connected to the circuit breakers (F3).

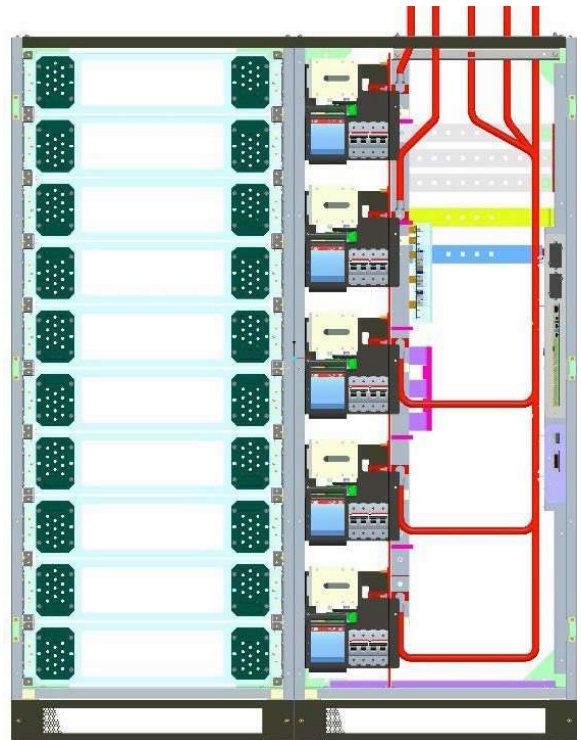

**Figure 4.11 Separate battery cable installation and connection**

All power connections are made to busbars located in the UPS cabinet right-hand side.

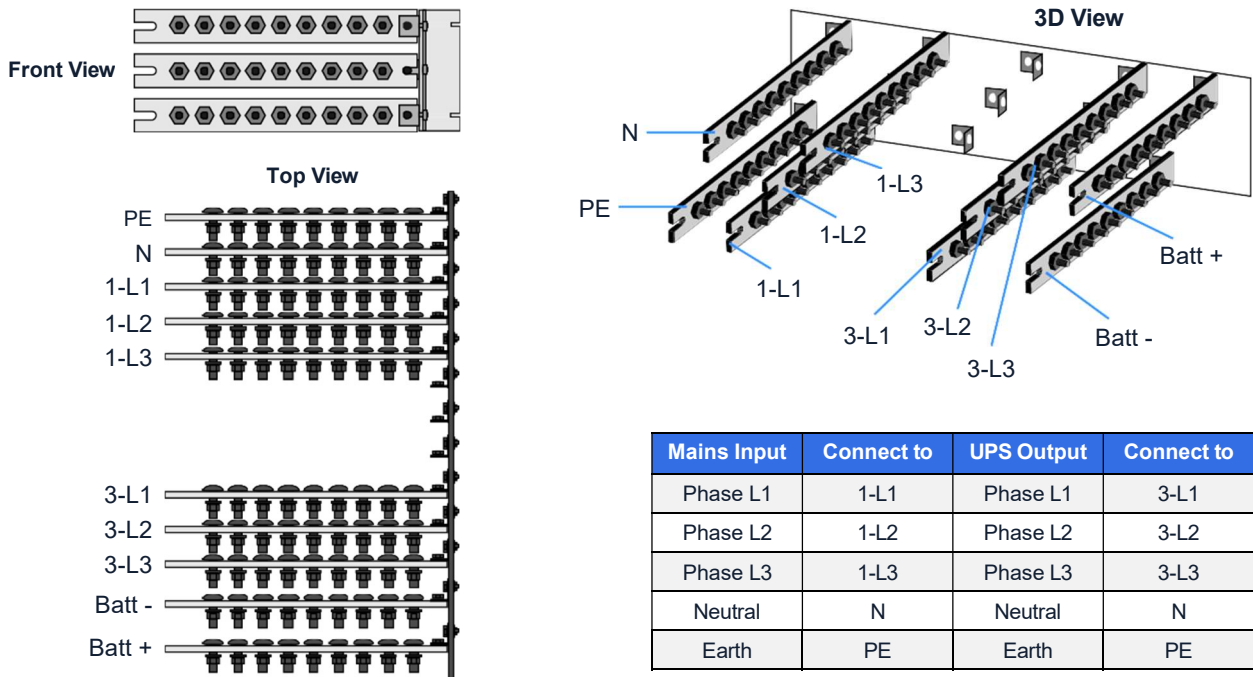

Figure 4.12 Single input with common battery

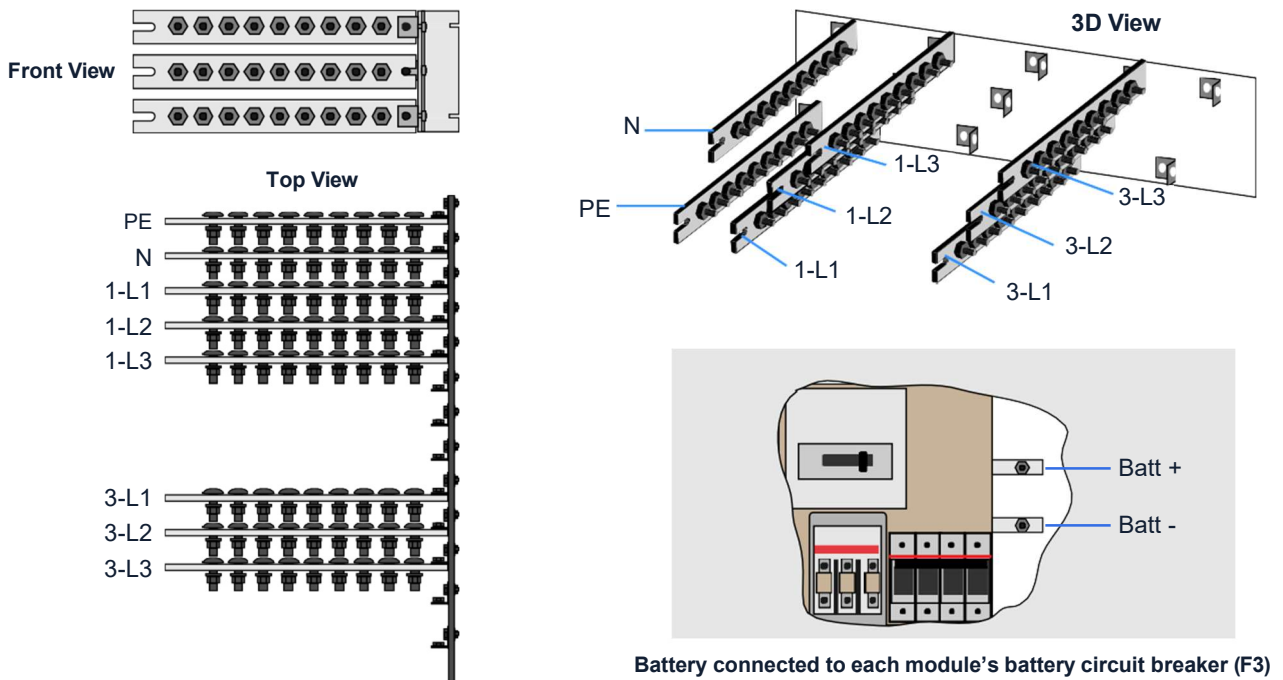

Figure 4.13 Single input with separate batteries

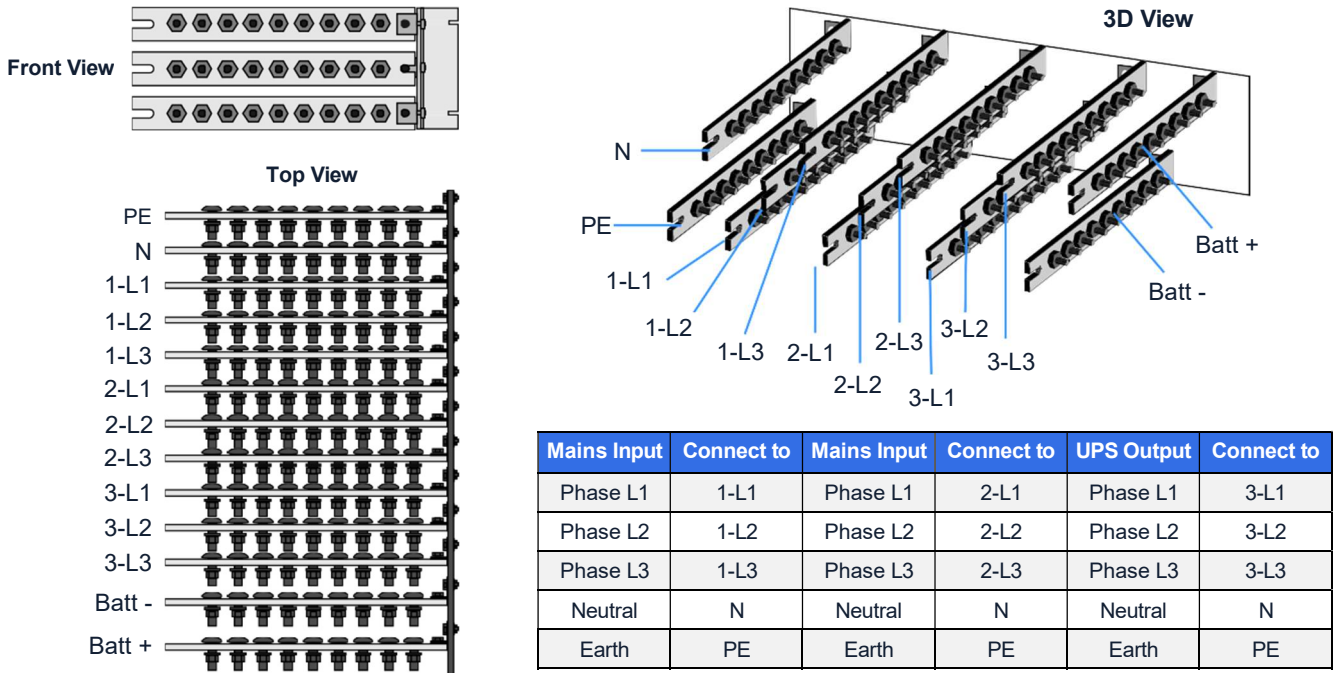

Figure 4.14 Dual input with common battery

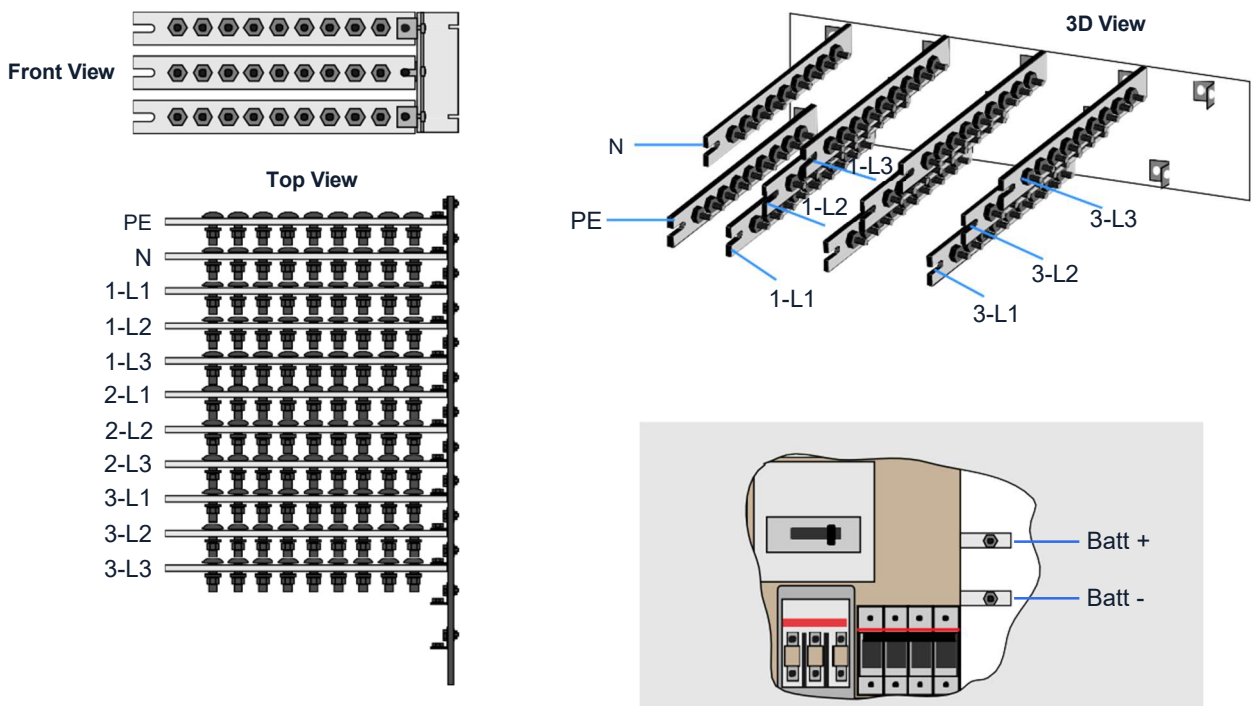

Figure 4.15 Dual input with separate batteries

#### 4.6 UPS Cabling procedure



**WARNING:** If you open or remove any UPS cabinet internal cover there is a risk of exposure to dangerous voltages if power is connected to the UPS.



**WARNING:** DC cabling for the battery system(s) must be completed by a Rehiko engineer or one of its approved service agents.

##### 4.6.1 Safety notes

Please ensure you read and understand the following safety notes before you begin the UPS electrical installation.

1. All the operations detailed in this section must be performed or supervised by a qualified, authorised electrician.
2. Once the electrical installation is completed the initial UPS start-up must be performed by a qualified commissioning engineer, trained and authorised by the manufacturer.
3. Do not operate the UPS if there is water or moisture present.
4. When working on the UPS input power cables, you must ensure that the UPS system input mains supply (and bypass mains supply in a dual feed system) is isolated at the UPS system input switchgear panel and, where possible, locked out. Warning notices should be posted where applicable to prevent the inadvertent operation of the LV supply isolator(s).
5. Ensure the following conditions are met prior to starting work on the equipment:
  - a. No mains voltage is present from the mains switchgear panel.
  - b. All loads are shut down and disconnected.
  - c. The UPS is shut down and voltage-free.

##### 4.6.2 Preparing the UPS power cabling

Before you connect the UPS input cables:

1. Ensure the UPS is fully installed mechanically at its intended final location.
2. Ensure that the provided fuses and cables are in accordance with the prescribed IEC Standards or local regulations (e.g. BS7671).
3. We recommended that the UPS system output is connected to a load distribution board via a suitably rated output protection device:
  - a. Check that the potential full load does not exceed the UPS output power rating (OUTPUT POWER on the UPS nameplate).
  - b. Ensure the circuit breakers on the load distribution board are correctly sized with respect to the load rating and associated cabling.
  - c. Ensure that the maximum total load rating, and maximum load rating of each individual load socket, is indicated on the load distribution board.
4. Gain access to the UPS power connection busbars by removing the covers in the right-hand UPS cabinet.

##### 4.6.3 Connecting the UPS input cables

1. Gain access to the UPS power connection busbars by removing the covers in the right-hand UPS Cabinet.
2. Connect the earth cable from the mains distribution board(s) to the protective earth (PE) busbar, as shown in Figure 4.12 to Figure 4.15.

##### Single Feed Input

3. Refer to the schematic drawing and connection table in Figure 4.12 (common battery system) or Figure 4.13 (separate battery system).

4. Connect the UPS input mains supply cables to busbars 1L1, 1L2, 1L3 and 1N on the UPS terminal block. Ensure correct (clockwise) phase rotation.



**CAUTION:** The input Neutral cable must be unswitched and permanently connected.

5. Secure the cables to the fixing rail located beneath the connection busbars.

#### Dual Feed Input

6. Refer to the schematic drawing and connection table in Figure 4.14 (common battery system) or Figure 4.15 (separate battery system).
7. Connect the UPS input mains supply cables to busbars 1-L1, 1-L2, 1-L3 and N. Ensure correct (clockwise) phase rotation.
8. Connect the UPS bypass mains supply cables to terminals 2-L1, 2-L2, 2-L3 and N. Ensure correct (clockwise) phase rotation. Note that if the UPS input and bypass supplies are connected to a common mains supply source then there is no need to connect the bypass neutral.



**CAUTION:** The input and bypass Neutral cables must be unswitched and permanently connected.

9. Secure the cables to the fixing rail located beneath the connection busbars.

#### 4.6.4 Connecting the UPS output cables

1. Connect the protective earth cable from the load distribution board to the protective earth (PE) busbar in the UPS.
2. Connect the UPS output supply cables to busbars 3-L1, 3-L2, 3-L3 and N. Ensure correct (clockwise) phase rotation.



**CAUTION:** The output Neutral cable must ALWAYS be connected.

3. Secure the cables to the fixing rail located beneath the connection busbars.
4. Ensure the output cables are securely connected to the correct power terminals on the load distribution board.

#### 4.6.5 Connecting the battery cables

The DC cabling for the battery system(s) must be completed by a Rehiko engineer or one of its approved service agents. The customer installation team is only responsible for providing any necessary containment for the DC cables.



**WARNING:** Do not attempt to fit the batteries, complete the battery wiring or close the battery isolators before the system has been commissioned.

#### 4.6.6 Multi-cabinet parallel control cabling and configuration

In a multi-cabinet UPS system various control functions such as load sharing, frequency synchronisation and load transfer are made possible by connecting a low voltage communications cable between the cabinets.

The parallel control cabling must be completed by a Rehiko engineer or one of its approved service agents. The customer installation team is only responsible for providing any necessary containment for the inter-cabinet cables where necessary cables.

#### 4.6.7 Module customer interface facilities

Each UPS cabinet is fitted with a customer interface board which enables various external monitoring and control applications to be connected to the system to satisfy particular site requirements.

Details of the interface facilities and available options are provided in Chapter 9.



**Key Point:** All used options should be installed and connected prior to commissioning the UPS so that they can be functionally checked as part of the commissioning procedure.

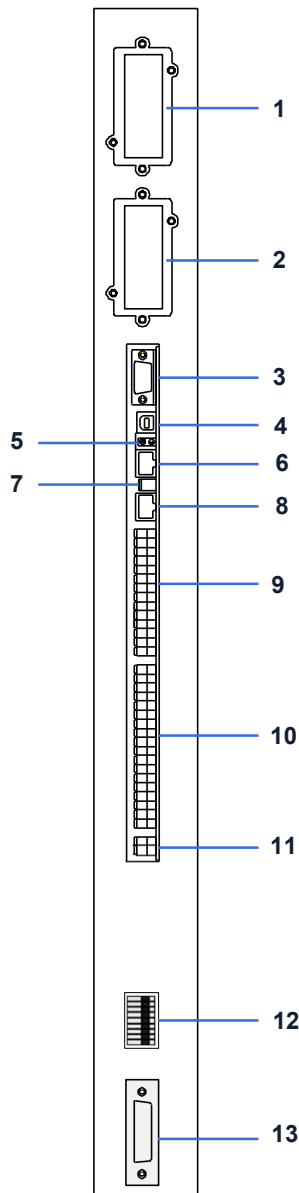

1	MODEM	Slot for optional Modem/Ethernet card ONLY.
2	SNMP	Slot for optional SNMP card ONLY.
3	JD1	Sub D9 female connector RS232 User interface – UPS system to computer.
4	USB	Standard USB interface – UPS system to computer.
5	LEDs	2 LEDs that indicate the interface board status.
6	JR3	RJ45 Port RS485 communication for remote panel.
7	DIP SW	Module selection used by multidrop configuration.
8	JR2	RJ45 Port RS485 communication for multidrop cable connected between all the UPS cabinets. Used with RJ45 splitter adapter to enable module daisy chaining.
9	X3	Terminal block used for external customer inputs.
10	X2	Terminal block with volt-free outputs for use with customer remote indications panel.
11	X1	Castell interlock function.
12	SW1-9	9-pole configuration DIP switch used to configure module for parallel operation.
13	JD8	Parallel communication bus connector. Used in parallel cabinet system only, and fitted with parallel adapter board to enable module daisy chaining.

Figure 4.16 UPS Customer interface board connectors

## 5. Operating Instructions 1

(for systems with a maintenance bypass)

### IMPORTANT NOTE

This chapter contains the operating instructions that should be used if the UPS system contains the 'optional' Maintenance Bypass facility – i.e. if the internal Maintenance Bypass Switch is fitted in the UPS cabinet or the UPS is connected to an external bespoke Maintenance Bypass switch panel.

If the UPS system design does not include a Maintenance Bypass facility you should use the operating instructions contained in Chapter 6.

### 5.1 Introduction

#### 5.1.1 Commissioning

The PW 9500DPA UPS is a high quality, complex electronic system which must be commissioned by an authorised Rehiko engineer before it is put into use.

The commissioning engineer will:

- check the UPS electrical and mechanical installation, and operating environment
- install and connect the UPS batteries
- check the UPS configuration settings
- check the installation and operation of any optional equipment
- perform a controlled UPS start-up
- fully test the system for correct operation
- provide customer operator training and equipment handover



**WARNING:** Rehiko will not accept responsibility for the equipment or the safety of any personnel if the UPS system is operated before it has been fully commissioned.

The manufacturer's warranty will be invalidated if power is applied to any part of the UPS system before it has been fully commissioned and handed over to the customer.

#### 5.1.2 Operating procedure summary

Under normal circumstances all the UPS modules in a multi-module system are turned on and operating in their 'on-inverter' mode. If one module fails in a 'redundant module' system the faulty module shuts down but it will not affect the remaining module(s), which will continue to operate normally and provide protected load power. The failed module can be replaced by a trained UPS service engineer without affecting the operation of the UPS system.

If a UPS module fails in a 'capacity' rated (or single module) system, the load will immediately transfer to the static bypass (in all modules) and will be connected to the unprotected bypass mains power supply.

A parallel-cabinet UPS system requires an external maintenance bypass facility which wraps around the entire UPS system – this is optional in a single cabinet installation. The external maintenance bypass is bespoke to the installation and can be installed in a separate cabinet or switchgear panel (see *paragraph 4.5.3*). If an external maintenance bypass is installed you should familiarise yourself with its operating procedures before using the UPS operating procedures contained in this chapter.



**CAUTION:** In a multi-cabinet system the UPS cabinet's internal maintenance bypass switch (IA1) is usually removed.

*Note: All the switches and control panel operations mentioned in this chapter are identified and described in chapter 2.*

The commissioning engineer will hand-over the system in a fully working condition with all the UPS modules turned on and operating in the 'on-inverter' mode (or 'on bypass' mode, if appropriate).

### 5.1.3 General warnings



**WARNING:** The procedures given below must be performed by a trained operator.



**WARNING:** When the UPS system is operating on BYPASS or via the MAINTENANCE BYPASS SWITCH, the load supply is unprotected if the bypass mains supply fails. It is essential that the load user is informed of this possibility before you select these operating modes.



**WARNING:** When the UPS is shut down, power is still applied to the UPS modules and the cabinet input/ bypass terminals unless the input/bypass mains is isolated at the mains switchgear panel. In a single cabinet installation it is not permissible to turn off the external input/bypass mains supply when the load is connected via the internal maintenance bypass switch (IA1) as this will also disconnect the load power.

## 5.2 Operating instructions

Under normal operating conditions all the UPS modules are running and operating in the on-inverter mode. This chapter contains the following procedures:

- How to start the UPS system from a fully powered-down condition - see paragraph 5.3 .
- How to start the UPS system from the maintenance bypass - see paragraph 5.4 .
- How to transfer the load to maintenance bypass - see paragraph 5.5 .
- How to shut down the complete UPS system - see paragraph 5.6 .
- Operating in 'on bypass' mode - see paragraph 5.7 .

### 5.3 How to start the UPS system from a fully powered-down condition

#### IMPORTANT NOTE

In the following procedures, all references to the 'Maintenance Bypass Switch' apply to the internal maintenance bypass switch (IA1) in the case of a single cabinet if it is not connected to an external maintenance bypass facility.

If an external maintenance bypass facility is installed (standard in a parallel-cabinet system) all references to the 'Maintenance Bypass Switch' apply to the maintenance bypass switch in the external facility.



**CAUTION:** In a multi-cabinet system ALWAYS use the external maintenance bypass facility. DO NOT operate the internal cabinet maintenance bypass switches (IA1).



**Key Point:** In order to reduce the possible effects of any high inrush currents that might occur when the load is initially turned on, we recommend that you power-up the load when the UPS system is operating on maintenance bypass, as described in this procedure.

You should familiarise yourself with the operation of the external maintenance bypass circuit operation before using this procedure.

#### Initial conditions:

This procedure assumes the following initial conditions:

- The UPS maintenance bypass switch is open.
- The UPS system input supply is isolated.
- The external UPS system output isolator is open.

### Power-up the load:

1. Connect the UPS system input supply.
  - a. Power will be applied to the UPS modules, but they will be turned OFF.
2. On every module control panel, verify that:
  - a. The LINE 1 LED is green.
  - b. The BATTERY LED is flashing red.
  - c. All other mimic LEDs are OFF
  - d. The LCD displays LOAD OFF , SUPPLY FAILURE.

If necessary press the RESET button to obtain this display.
3. Close the external UPS system output isolation device.
4. Close the UPS maintenance bypass switch.
5. Turn on the load equipment.
  - a. The load is now powered through the maintenance bypass.
  - b. The module control panel mimic indications do not change.
  - c. The LCD displays MANUAL BYP IS CLOSED.
6. Press the RESET button.
  - a. The LCD displays LOAD OFF , SUPPLY FAILURE.

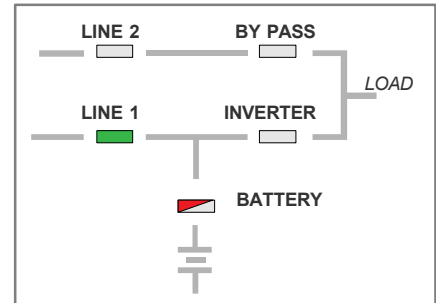

### Start the UPS module(s):

7. Carry out steps 8 to 14 on each UPS module in turn.
8. Close the bypass fuse (F2).
9. On the module control panel, simultaneously press both ON/OFF buttons.  
The UPS module will begin to power up over approximately 60s.
10. On the module control panel, after 60s verify that:
  - a. The LINE 2 LED is green (red during initial start-up).
  - b. The BYPASS LED is green.
  - c. The INVERTER LED is red.
  - d. The BATTERY LED is flashing red.
  - e. The LCD displays LOAD NOT PROTECTED.
11. Close the module's battery breaker (F3) and the external battery enclosure fuse.
12. On the module control panel, verify that:
  - a. The BATTERY LED flashes green then changes to a solid green within 5 minutes.
13. Close the parallel isolator switch (IA2).
14. On the module control panel, verify that:
  - a. The LCD displays PARALLEL SW CLOSED.
15. Before you continue, ensure that the indications on the module control panels of ALL modules are identical, and as described above.

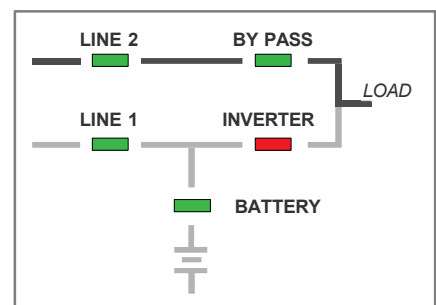
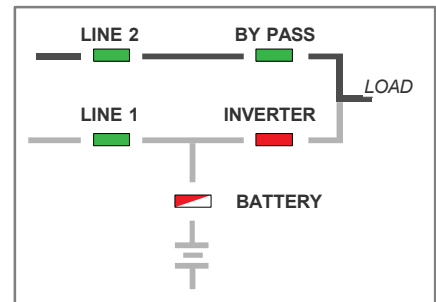

### Transfer the load to inverter:

16. If the BYPASS LED is green (on ALL modules), open the maintenance bypass switch.
 

*Note: If the BYPASS LED is not green, repeat step 7 then seek trained advice if it still fails to light green.*
17. Press the Home button on the display header bar.
  - a. The HOME screen should open.

18. Press the Command button of the HOME screen.
  - a. The COMMAND screen should open.
19. Press the Load to Inverter button on the COMMANDS screen
  - a. All UPS modules will transfer the load to the inverter
20. On the system control panel check that the UPS mimic indicates the load on inverter.
21. Check that the display header bar Load Status indicates that the load is protected.

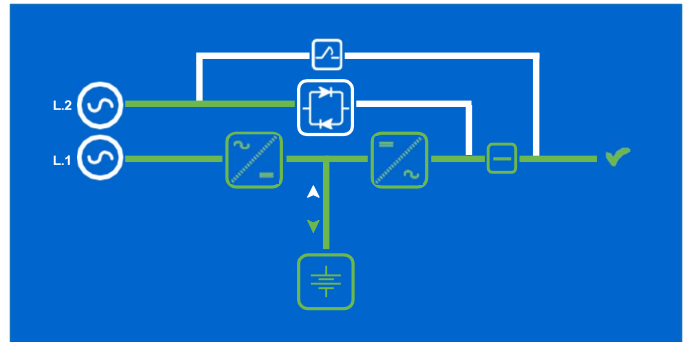

**Key Point:** The UPS system is now operating in its 'on-inverter' mode and the load is fully protected.

#### 5.4 How to start the UPS system from the maintenance bypass

##### IMPORTANT NOTE

In the following procedures, all references to the 'Maintenance Bypass Switch' apply to the internal maintenance bypass switch (IA1) in the case of a single cabinet if it is not connected to an external maintenance bypass facility.

If an external maintenance bypass facility is installed (standard in a parallel-cabinet system) all references to the 'Maintenance Bypass Switch' apply to the maintenance bypass switch in the external facility.



**Key Point:** If the load is not already turned on, turn it on now, while the UPS system is operating on maintenance bypass, before you continue with this procedure.

##### Initial conditions:

This procedure assumes the following initial conditions.

- The load is connected to the maintenance bypass supply.
- The UPS system input supply is connected to the UPS.
- The external UPS system output isolation device is closed.
- The load equipment is turned on and receiving power through the UPS maintenance bypass.

##### Powering up the UPS system:

If the UPS system is operating on maintenance bypass it can be powered up using the procedure described in paragraph 5.3 ("*How to start the UPS system from a fully powered-down condition*") beginning at step 7.

#### 5.5 How to transfer the load to maintenance bypass

##### IMPORTANT NOTE

In the following procedures, all references to the 'Maintenance Bypass Switch' apply to the internal maintenance bypass switch (IA1) in the case of a single cabinet if it is not connected to an external maintenance bypass facility.

If an external maintenance bypass facility is installed (standard in a parallel-cabinet system) all references to the 'Maintenance Bypass Switch' apply to the maintenance bypass switch in the external facility.

The load can be transferred to the maintenance bypass supply, and the UPS modules turned off, when troubleshooting a 'system level' fault or replacing a UPS module in a 'capacity' rated system. This procedure is normally carried out by a trained service engineer and is not usually part of the day-to-day management of the UPS system.



**CAUTION:** The load is not protected when operating on the Maintenance Bypass.

**Initial conditions:**

This procedure assumes one of the following initial conditions.

1. The UPS system is operating normally, on-inverter – continue with step 3:

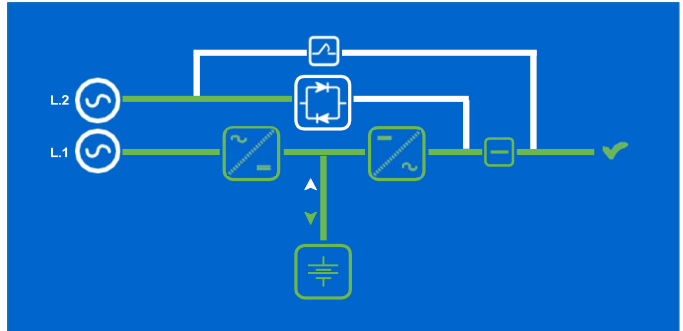

2. The UPS system is operating with the load on bypass due to a system fault, severe overload, loss of redundancy or operating in 'ECO' mode – continue with step 8:

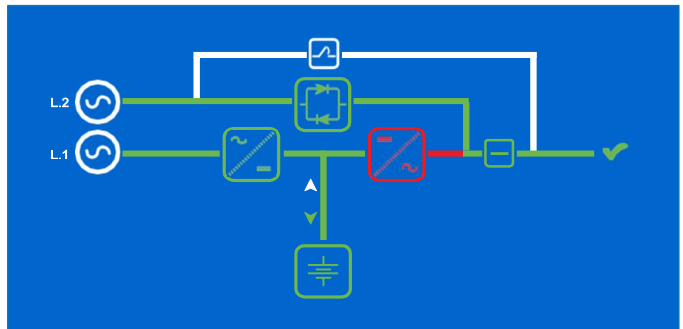

**Transfer the UPS to on-bypass mode:**

**Using the system control panel**

3. Press the Home button on the display header bar.
  - a. The HOME screen should open.
4. Press the Command button of the HOME screen.
  - a. The COMMAND screen should open.
5. Press the Load to Bypass button on the COMMANDS screen.
  - a. All UPS modules will transfer the load to the static bypass.
6. On the system control panel check that the UPS mimic indicates the load on static bypass.
7. Check that the display header Load Status indicates that the load is protected.

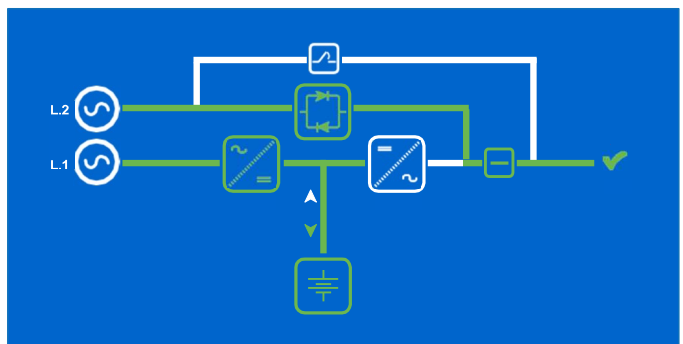

### Transfer the load to maintenance bypass:

8. Close the maintenance bypass switch.
9. On the system control panel, verify that:
  - a. The INVERTER icon is red.
  - b. The BYPASS icon is green.
  - c. The Maintenance Bypass line is yellow.
  - d. The audible alarm activates and a **MANUAL BYPASS IS CLOSED** event is registered.
10. Press the **RESET** button (*on all UPS modules*) to cancel the audible alarm.
11. Check that the display header bar **Load Status** indicates that the load is not protected

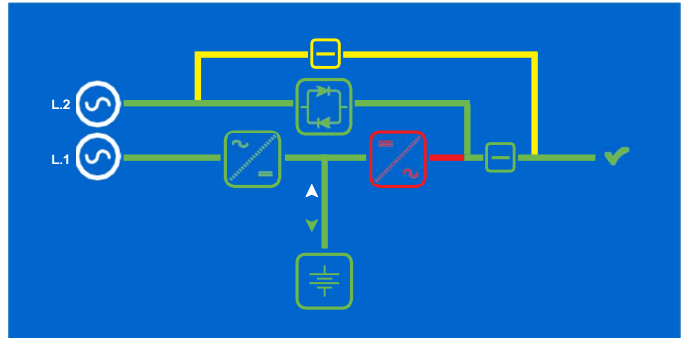

### Turn off the UPS module:

12. Carry out steps 13 to 16 on each UPS module in turn.
13. On the module control panel, simultaneously press both **ON/OFF** buttons and verify that:
  - a. All LEDs turn **OFF** except for **LINE 1** and **BATTERY** (flashing green).
14. Open the module's parallel isolator (IA2).
15. Open the module's bypass fuse (F2).
16. Open the battery breaker (F3).
17. To totally isolate the battery also open the external battery breakers/fuses.

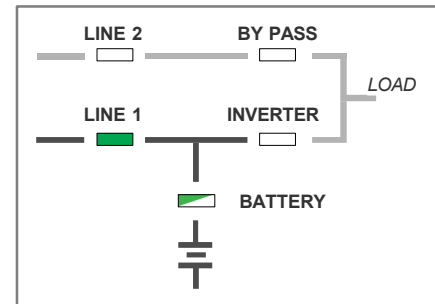

The load is now connected directly to the mains supply via the maintenance bypass circuit. In the case of a single cabinet installation using the internal maintenance bypass switch (IA1), the external UPS system input isolators must remain closed to support the load, and the UPS cabinet's input/bypass and output power terminals will remain live. Where an external maintenance bypass facility is used, the UPS system input supply can be turned off – see the operating instructions for the bespoke external maintenance bypass facility for details.

## 5.6 How to shut down the complete UPS system

If the load does not require power for an extended period of time, the UPS system can be completely shut down using the following procedure.

1. Transfer the load to the maintenance bypass as described in paragraph 5.5.
2. Isolate all load equipment by opening the individual load protection devices (switches/circuit breakers etc.)
3. Open the maintenance bypass switch.
4. Open the external UPS system output isolation device.
5. Turn off the UPS system input supply. Where used, refer to the operating instructions for the bespoke external maintenance bypass facility for additional details of how to isolate the UPS mains supply if necessary.
6. The UPS cabinet is now voltage free.

## 5.7 Operating in 'on bypass' mode

When operating the UPS system in 'on bypass' mode, the load is powered normally through the UPS bypass supply and switches to the inverter ('on inverter') automatically if the bypass supply fails.



**CAUTION:** *There will be a short supply break when the UPS switches to the 'on-inverter' mode, so you should elect to operate in the 'on bypass' mode only if a load can withstand a brief supply break.*

### 5.7.1 How to Turn ON the UPS in 'on bypass' mode

1. Use the standard operating instructions in paragraph 5.3 but do not perform the "Transfer the load to inverter:" stage (step 16 onwards).

### 5.7.2 How to Turn OFF the UPS in 'on bypass' mode

1. Use the standard operating instructions in paragraph 5.5 beginning at step 8 – as the load is already operating on bypass.

### 5.7.3 How to transfer between 'on bypass' and 'on inverter' mode

The UPS can be manually switched between the 'on bypass' and 'on inverter' mode through the module control panel load transfer menu.

#### Transfer the UPS to on-bypass mode:

##### Using the system control panel

1. Press the Home button on the display header bar.
  - a. The HOME screen should open.
2. Press the Command button of the HOME screen.
  - a. The COMMAND screen should open.
3. Press the Load to Bypass button on the COMMANDS screen
  - a. All UPS modules will transfer the load to the inverter
4. On the system control panel check that the UPS mimic indicates the load on inverter.
5. Check that the display header Load Status indicates that the load is protected.

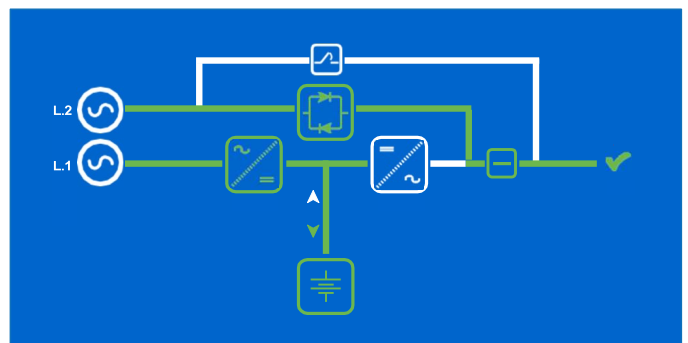

#### Transfer from 'on bypass' to 'on inverter' mode:

##### Using the system control panel

1. Press the Home button on the display header bar.
  - a. The HOME screen should open.
2. Press the Command button of the HOME screen.
  - a. The COMMAND screen should open.
3. Press the Load to Inverter button on the COMMANDS screen
  - a. All UPS modules will transfer the load to the inverter
4. On the system control panel check that the UPS mimic indicates the load on inverter.
5. Check that the display header Load Status indicates that the load is protected.

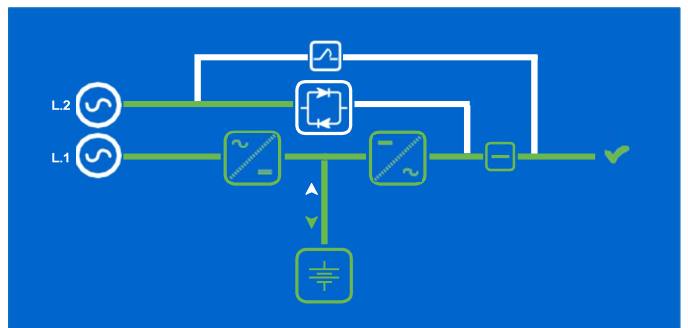

## 6. Operating Instructions 2

(for systems without a maintenance bypass)

### IMPORTANT NOTE

This chapter contains the operating instructions that should be used if the UPS system does not contain the 'optional' Maintenance Bypass facility – i.e. there is no internal Maintenance Bypass Switch fitted in the UPS cabinet and the UPS is not connected to an external Maintenance Bypass switch panel.

If a Maintenance Bypass facility is included in the UPS system design you should use the operating instructions contained in Chapter 5.

### 6.1 Introduction

#### 6.1.1 Commissioning

The PW 9500DPA UPS is a high quality, complex electronic system which must be commissioned by an authorised Rehiko engineer before it is put into use.

The commissioning engineer will:

- check the UPS electrical and mechanical installation, and operating environment
- install and connect the UPS batteries
- check the UPS configuration settings
- check the installation and operation of any optional equipment
- perform a controlled UPS start-up
- fully test the system for correct operation
- provide customer operator training and equipment handover



**WARNING:** Rehiko will not accept responsibility for the equipment or the safety of any personnel if the UPS system is operated before it has been fully commissioned.

The manufacturer's warranty will be invalidated if power is applied to any part of the UPS system before it has been fully commissioned and handed over to the customer.

#### 6.1.2 Operating procedure summary

Under normal circumstances all the UPS modules in a multi-module system are turned on and operating in their 'on-inverter' mode. If one module fails in a 'redundant module' system the faulty module shuts down but it will not affect the remaining module(s), which will continue to operate normally and provide protected load power. The failed module can be replaced by a trained UPS service engineer without affecting the operation of the UPS system.

If a UPS module fails in a 'capacity' rated (or single module) system, the load will immediately transfer to the static bypass (in all modules) and will be connected to the unprotected bypass mains power supply.

*Note: All the switches and control panel operations mentioned in this chapter are identified and described in chapter 2.*

The commissioning engineer will hand-over the system in a fully working condition with all the UPS modules turned on and operating in the 'on-inverter' mode (or 'on bypass' mode, if appropriate).

### 6.1.3 General warnings



**WARNING:** The procedures given below must be performed by a trained operator.



**WARNING:** When the UPS system is operating on BYPASS, the load supply is unprotected if the bypass mains supply fails. It is essential that the load user is informed of this possibility before you select these operating modes.

### 6.2 Operating instructions

Under normal operating conditions all the UPS modules are running and operating in the on-inverter mode. This chapter contains the following procedures:

- How to start the UPS system from a fully powered-down condition - see paragraph 6.3 .
- How to turn off the load and power-down the UPS system - see paragraph 6.4 .
- Operating in 'on bypass' (ECO) mode - see paragraph 6.5 .

### 6.3 How to start the UPS system from a fully powered-down condition



**Key Point:** In order to reduce the possible effects of any high inrush currents that might occur when the load is initially turned on, we recommend that you power-up the load when the UPS system is operating on bypass, as described in this procedure.

#### Initial conditions:

This procedure assumes the following initial conditions:

- The UPS system input supply isolated.
- The external UPS system output isolator is open.

#### Power-up the UPS:

1. Connect the UPS system input supply.
  - a. Power will be applied to the UPS modules, but they will be turned OFF.
2. On every module control panel, verify that:
  - a. The LINE 1 LED is green.
  - b. The BATTERY LED is flashing red.
  - c. All other mimic LEDs are OFF
  - d. The LCD displays LOAD OFF , SUPPLY FAILURE.

If necessary press the RESET button to obtain this display.
3. Close the external UPS system output isolation device(s).
4. Press the RESET button.
  - a. The LCD displays LOAD OFF , SUPPLY FAILURE.

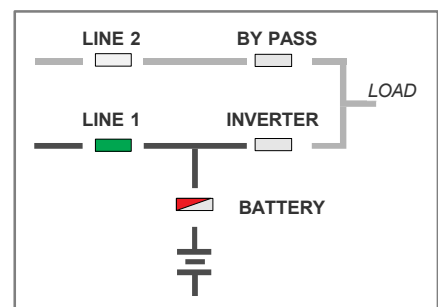

### Start the UPS module(s):

5. Carry out steps 6 to 12 for each UPS module in turn.
6. Close the bypass fuse (F2).
7. Close the parallel isolator switch (IA2).
8. On the module control panel, simultaneously press both ON/OFF buttons.  
The UPS module will begin to power up over approximately 60s.
9. On the module control panel, after 60s verify that:
  - a. The LINE 2 LED is green (red during initial start-up).
  - b. The BYPASS LED is green.
  - c. The INVERTER LED is red.
  - d. The BATTERY LED is flashing red.
  - e. The LCD displays LOAD NOT PROTECTED.
10. Close the module's battery breaker (F3) and the external battery enclosure breaker/ fuses.
11. On the module control panel, verify that:
  - a. The BATTERY LED flashes green then changes to a solid green within 5 minutes.
12. On the module control panel, verify that:
  - a. The LCD displays PARALLEL SW CLOSED.
13. Before you continue, ensure that the indications on the module control panels of ALL modules are identical, and as described above.

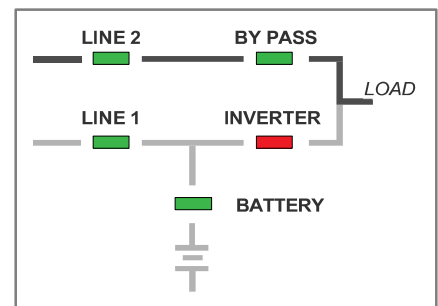
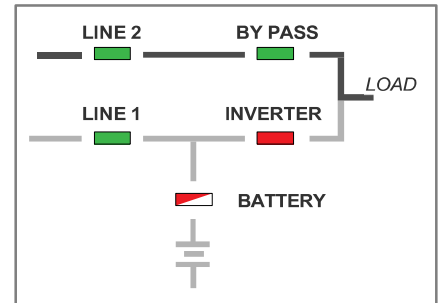

**CAUTION:** Do not proceed unless the BYPASS LED is green on ALL UPS modules.  
If any BYPASS LED still fails to light green, repeat step 5, then seek trained advice if necessary

14. Turn on the load equipment.
  - a. The load is now powered through the static bypass.
  - b. The module control panel mimic indications do not change.

### Transfer the load to inverter:

15. Press the Home button on the display header bar.
  - a. The HOME screen should open.
16. Press the Command button of the HOME screen.
  - a. The COMMAND screen should open.
17. Press the Load to Inverter button on the COMMANDS screen
  - a. All UPS modules will transfer the load to the inverter
18. On the system control panel check that the UPS mimic indicates the load on inverter.
19. Check that the display header bar Load Status indicates that the load is protected.

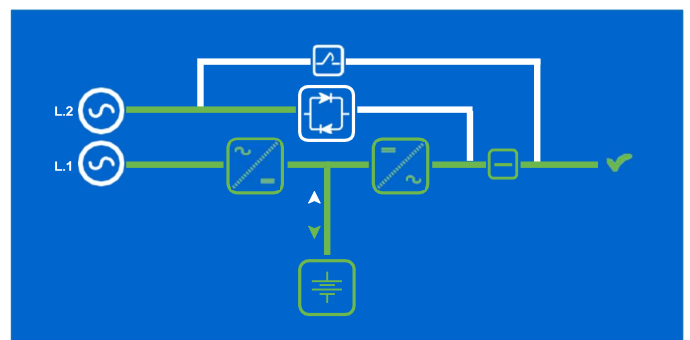

**Key Point:** The UPS system is now operating in its 'on-inverter' mode and the load is fully protected.

## 6.4 How to turn off the load and power-down the UPS system

Use this procedure to fully power-down the UPS system.



**WARNING:** The load user should be informed before you begin this procedure as it will totally power-down the critical load equipment

### Initial conditions:

This procedure assumes one of the following initial conditions.

1. The UPS system is operating normally, on-inverter – continue with step 3:

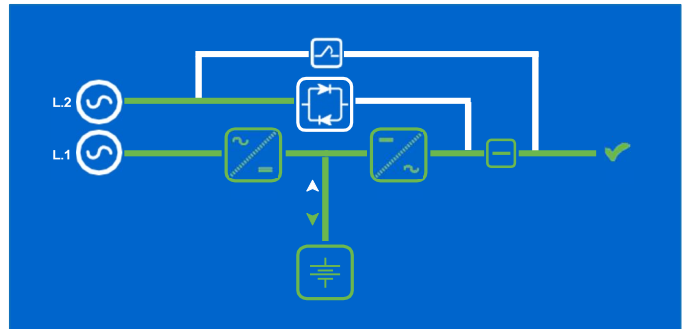

2. The UPS system is operating with the load on bypass due to a system fault, severe overload, loss of redundancy or operating in 'ECO' mode – continue with step 9:

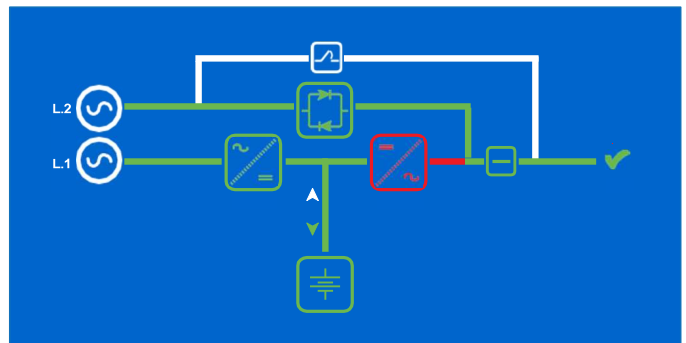

### Transfer the UPS to on-bypass mode:

#### Using the system control panel

3. Press the Home button on the display header bar.
  - a. The HOME screen should open.
4. Press the Command button of the HOME screen.
  - a. The COMMAND screen should open.
5. Press the Load to Bypass button on the COMMANDS screen.
  - a. All UPS modules will transfer the load to the static bypass.
6. On the system control panel check that the UPS mimic indicates the load on static bypass.
7. Check that the display header Load Status indicates that the load is not protected.
8. When it is safe to do so, turn off the connected load equipment.

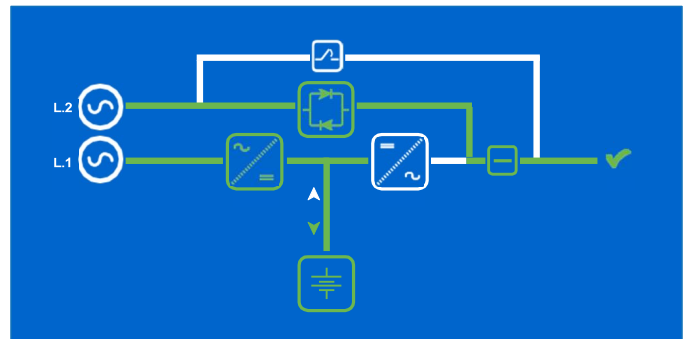

### Turn off the UPS module(s):

9. Carry out steps 10 to 13 on each UPS module in turn.
10. On the module control panel, simultaneously press both ON/OFF buttons and verify that:
  - a. All LEDs turn OFF except for LINE 1 and BATTERY (flashing green).
11. Open the module's parallel isolator (IA2).
12. Open the module's bypass fuse (F2).
13. Open the battery breaker (F3).
14. To totally isolate the battery also open the external battery breaker/fuses.
15. Open the external UPS system output isolation device.
16. Turn off the UPS system input supply.

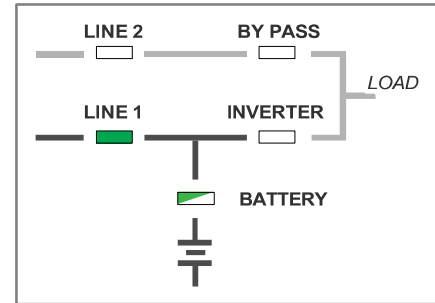

**Key Point:** The UPS cabinet is now voltage free.

## 6.5 Operating in 'on bypass' (ECO) mode

When operating the UPS system in 'on bypass' mode, the load is powered normally through the UPS bypass supply and switches to the inverter ('on inverter') automatically if the bypass supply fails.



**CAUTION:** There will be a short supply break when the UPS switches to the 'on-inverter' mode, so you should choose to operate in the 'on bypass' (ECO) mode only if a load can withstand a brief supply break.

### 6.5.1 How to Turn ON the UPS in 'on bypass' mode

1. Use the standard operating instructions in paragraph 6.3 but do not perform the "Transfer the load to inverter:" stage (step 15 onwards).

### 6.5.2 How to Turn OFF the UPS in 'on bypass' mode

1. Use the standard operating instructions in paragraph 6.4 beginning at step 9 – as the load is already operating on bypass.

### 6.5.3 How to transfer between 'on bypass' and 'on inverter' mode

The UPS can be manually switched between the 'on bypass' and 'on inverter' mode through the module control panel load transfer menu.

#### Transfer the UPS to on-bypass mode:

##### Using the system control panel

1. Press the Home button on the display header bar.
  - a. The HOME screen should open.
2. Press the Command button of the HOME screen.
  - a. The COMMAND screen should open.
3. Press the Load to Bypass button on the COMMANDS screen.
  - a. All UPS modules will transfer the load to the inverter

4. On the system control panel check that the UPS mimic indicates the load on inverter.
5. Check that the display header Load Status indicates that the load is protected.

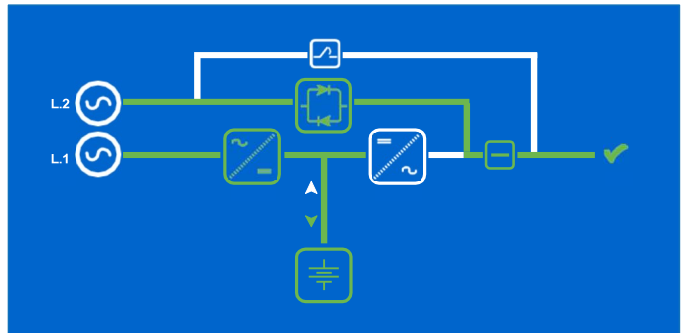

### Transfer from 'on bypass' to 'on inverter' mode:

#### *Using the system control panel*

1. Press the Home button on the display header bar.
  - a. The HOME screen should open.
2. Press the Command button of the HOME screen.
  - a. The COMMAND screen should open.
3. Press the Load to Inverter button on the COMMANDS screen
  - a. All UPS modules will transfer the load to the inverter
4. On the system control panel check that the UPS mimic indicates the load on inverter.
5. Check that the display header Load Status indicates that the load is protected.

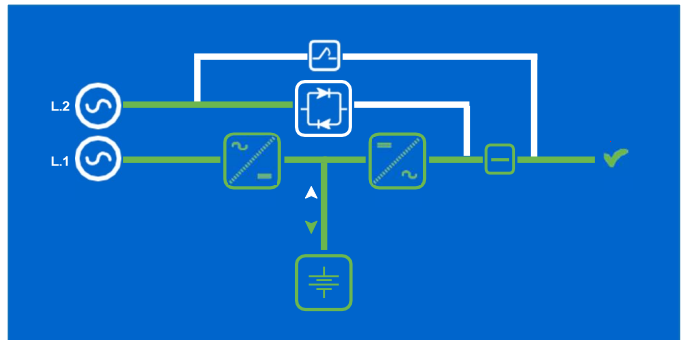

## 7. Maintenance

### 7.1 Introduction



**WARNING:** All the operations described in this chapter must be performed by trained personnel.

The UPS does not contain any user-serviceable parts, however, the UPS contains life limited components that require to be replaced at regular intervals, so the maintenance requirements for the user are minimal other than to ensure the environment in which the UPS is installed is kept cool and dust free. A clean operating environment will help maximise the useful working life and reliability of both the UPS and its batteries.

### 7.2 Scheduled maintenance



**WARNING:** Preventative maintenance inspections involve working inside the UPS which contains hazardous AC and DC voltages, and should be performed only by an authorised engineer who has been trained by Rehiko

It is essential that the UPS system and batteries receive regular preventative maintenance in accordance with the manufacturer's recommendations and any life limited components replaced at the required intervals and critical updates performed to maximise both the useful working life and system reliability. When the UPS is commissioned, the commissioning engineer will attach a service record book inside the front of the UPS which will be used to log its full service history.

We recommend that the UPS system is maintained every six months by a Rehiko trained engineer or approved service agent, who will complete the following.

#### 7.2.1 Preventative maintenance inspection

Preventative maintenance inspections form an integral part of all Extended Warranty Agreements (maintenance contracts) offered by Rehiko.

During a preventative maintenance inspection a trained Rehiko engineer will check and validate:

- |   |   |
|---|---|
| • Site/environment conditions               | • Integrity of electrical installation        |
| • Cooling airflow                           | • Rectifier/booster operation and calibration |
| • Inverter operation and calibration        | • Static switch operation                     |
| • Battery status and condition              | • Load characteristics                        |
| • Integrity of alarm and monitoring systems | • Correct operation of all installed options  |
| • Condition of life limited components      | • Manufacturer recommended updates            |

#### 7.2.2 System calibration

To ensure optimum UPS operation and efficient load protection we recommended that the system's operating parameters are checked and recalibrated where necessary.

During a system calibration a trained Rehiko engineer will check:

- Rectifier operation and calibration
- Inverter operation and calibration
- Bypass operation
- Battery status and perform a battery test

### 7.2.3 Battery maintenance and testing

The batteries should be checked and tested by a trained engineer every six months, depending on their operating temperature.

The battery test procedure can be carried out from the UPS front panel and performed irrespective of the UPS operating mode (ON-INVERTER or ON-BYPASS/ECO) and whether or not the load is connected.

A battery test takes approximately two minutes to complete and can be performed only if:

- There are no alarm conditions present.
- The battery is fully charged.
- The UPS input mains supply is present.

### Battery disposal and recycling

Batteries contain dangerous substances that can harm the environment if disposed of carelessly. If you have reason to change the batteries, always consult with your local environmental waste disposal organisations to obtain the recommended disposal and recycling information.

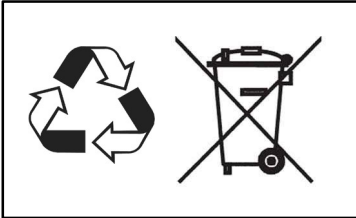

## 8. Troubleshooting

### 8.1 Fault and alarm indications

#### At the system control panel

If a system fault occurs, the audible alarm will sound and the Warning symbol will appear in the system control panel header bar. In this case proceed as follows:

1. Silence the audible alarm by pressing the RESET button.
2. Identify the cause of the alarm by viewing the detected problem on the EVENTS screen (see page 24).
3. If the fault relates to a UPS module the Module Selection button on the display header bar will be red. If you press the Module Selection button the faulty module will be identified in the MODULE SELECTION screen, as described on page 32.
4. If the alarm event is shown in the table in paragraph 8.2, follow the actions provided in that table. If the event is not shown in the table, or you have any doubts as to how to carry out the instructions given, then please contact Rehiko.

#### IMPORTANT NOTE

Certain alarm conditions may 'latch-on' even after the cause of the alarm is no longer present. For example, if there is a brief mains failure during unattended operation the MAINS RECT FAULT alarm will activate and it may still indicate a fault condition even after the mains supply has returned to normal.

If any of the following alarms appear, the first action to take is to attempt to RESET it.

- MAINS RECT FAULT
- MAINS BYP FAULT
- BYPASS IS OK
- BYPASS IS NOT OK

If the alarm resets then it was probably caused by a transient condition and is no longer present; the UPS has responded correctly and no further action is required. If it is not possible to reset the alarm, or if the alarm is repetitive, investigative action is necessary which may require assistance from the UPS Service department.

#### At the UPS module level

Fault events are displayed in date/time order on the module control panel as shown on page 16. To access the module control panel events log:

1. Press the UP key once to access the menu system.
2. Use the UP/DOWN keys to move the cursor so that it is adjacent to EVENTS.
3. Press the ENTER key.

Step through the logged events (up to 64) using the UP/DOWN keys and make a separate note of each alarm condition as this will assist in identifying any problems.

#### Menu, Commands, Event Log, Measurements,

When you seek service support it is important that you provide as much information as possible concerning the UPS problem as this will help expedite a swift and appropriate response. A description of the Menus, Commands, Event Log and Measurements that can be found on the module control panel is provided in paragraph 2.7.3.

Paragraph 8.2, below, illustrates a list of the most common Alarms and Messages. As you step through the event memory make a separate note of each recorded alarm condition as this will help identify the cause of any problems.

## 8.2 Fault identification and rectification

The interpretation and suggested solutions for the major alarm condition that you are most likely to encounter are shown in the table below. If the encountered alarm is not shown in the table, or you have any doubts as to how to safely carry out the instructions given, then please contact Rehiko on 0800 731 3269.

ALARM CONDITION	INTERPRETATION	SUGGESTED SOLUTION
MAINS BYP/RECT FAULT	Mains power supply is outside prescribed tolerance	The UPS input power is low or missing. If site power appears to be OK, check the UPS input supply fuses (breaker) at the distribution board.
OUTPUT SHORT	There is a short circuit at the output of UPS (on the load side)	Check all output connections and repair as required.
OVERLOAD	Load exceeds the UPS rated power	Identify which load item is causing the overload and disconnect/repair it. Do not connect extraneous laser printers, photocopiers, electric heaters, kettles etc. to the UPS if near capacity.
TEMPERATURE HIGH	UPS temperature has exceeded the allowed value	Check that the UPS temperature is less than 30° C. If the temperature is normal call an authorised service centre for assistance
BATT. CHARGER FAULT	The attached battery and the battery charger set-up do not correspond, or there is a battery charger fault.	Call an authorised service centre for assistance.
INV. PHASE FAULT	Inverter is faulty	Call an authorised service centre for assistance
BATTERY IN DISCHARGE	Battery is near end of autonomy	Shutdown the load connected to UPS before the UPS switches itself off to protect its batteries.
MANUAL BYP IS CLOSED	Maintenance bypass closed (optional). Load is being supplied by raw mains	This alarm is only displayed if the UPS is on maintenance bypass.

## 8.3 Contacting service

Rehiko has a service department dedicated to providing routine maintenance and emergency service cover for your UPS. For peace of mind we recommend that you protect your UPS with an extended warranty agreement, which will ensure that your UPS system and batteries are well maintained and running at their optimum efficiency, and attended to promptly should any problems occur.

### UK

[www.ups.rehiko.co.uk](http://www.ups.rehiko.co.uk)

[ukservice.ups@rehiko.com](mailto:ukservice.ups@rehiko.com)

[uktechnicalsupport.ups@rehiko.com](mailto:uktechnicalsupport.ups@rehiko.com)

[uksales.ups@rehiko.com](mailto:uksales.ups@rehiko.com)

[ukservicesales.ups@rehiko.com](mailto:ukservicesales.ups@rehiko.com)

Rehiko web site

Service department – booking service, fault reporting etc.

Technical queries

Hardware sales

Extended warranty agreements etc

### IRELAND

[www.ups.rehiko.ie](http://www.ups.rehiko.ie)

[ieinfo.ups@rehiko.com](mailto:ieinfo.ups@rehiko.com)

Rehiko web site

Service department, technical queries, hardware sales and extended warranty agreements

### SINGAPORE

[www.ups.rehiko.sg](http://www.ups.rehiko.sg)

[salesups.sg@rehiko.com](mailto:salesups.sg@rehiko.com)

[serviceups.sg@rehiko.com](mailto:serviceups.sg@rehiko.com)

Rehiko web site

Hardware sales

Contract customer support, maintenance contracts renewals

## 9. Options

### 9.1 Introduction

Each UPS cabinet is fitted with a customer interface board, as shown in Figure 9.1, which enables various external monitoring and control applications to be connected to the UPS system to satisfy particular site requirements. These interfaces are described below.

### 9.2 Customer interface board

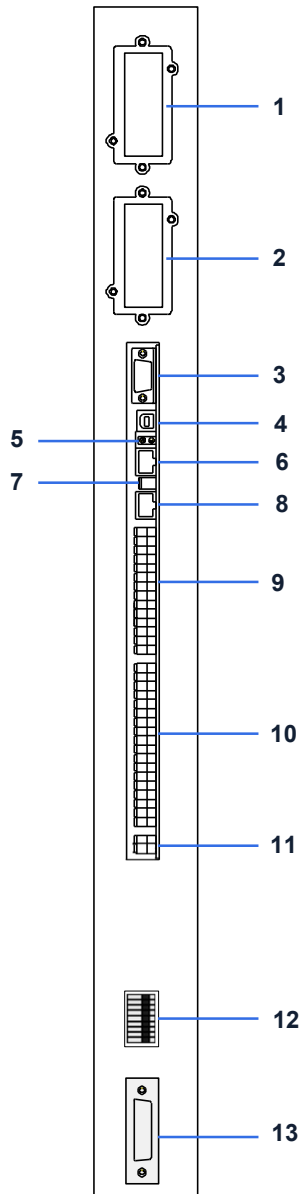

1	MODEM	Slot for optional Modem/Ethernet card ONLY.
2	SNMP	Slot for optional SNMP card ONLY.
3	JD1	Sub D9 female connector RS232 User interface – UPS system to computer.
4	USB	Standard USB interface – UPS system to computer.
5	LEDs	2 LEDs that indicate the interface board status.
6	JR3	RJ45 Port RS485 communication for remote panel.
7	DIP SW	Module selection used by multidrop configuration.
8	JR2	RJ45 Port RS485 communication for multidrop cable connected between all the UPS cabinets. Used with RJ45 splitter adapter to enable module daisy chaining.
9	X3	Terminal block used for external customer inputs.
10	X2	Terminal block with volt-free outputs for use with customer remote indications panel.
11	X1	Castell interlock function.
12	SW1-9	9-pole configuration DIP switch used to configure module for parallel operation.
13	JD8	Parallel communication bus connector. Used in parallel cabinet system only, and fitted with parallel adapter board to enable module daisy chaining.

Figure 9.1 UPS Cabinet customer interface board

A customer interface board, which is fitted to the front right-hand side of each UPS cabinet, provides various means of connecting 'cabinet' and 'system' level UPS monitoring and control interfaces to external devices (see Figure 9.1).

The customer interface board connections include:

- Dry-port inputs for customer remote control options (X3).
- Relay operated dry-port alarm outputs for remote monitoring (X2).
- RS232 computer interface for remote monitoring/control applications (JD1)
- RS232 computer interface for multidrop (JR2)
- USB port for computer monitoring applications
- An SNMP/CS141 card slot
- An SNMP slot for Modem/Ethernet card



**Key Point:** If the UPS is operating as a parallel cabinet system and the 'Multidrop' application is enabled, the customer interface board I/O is disabled in the 'slave' cabinet(s) and the interface connections should be made on the customer interface board fitted in the 'master' module only.

### 9.2.1 Serial RS-232/ USB Computer interface – JD1 & USB (Smart Port)

JD11 is an intelligent RS 232 serial port which allows the UPS cabinet to be connected to a computer for monitoring purposes. Its connector is a 9-pin female D-type and it can be connected to a computer using standard computer serial communications cable wired as shown below in Figure 9.2. The maximum length of the RS232 cable is 15m.

When used in conjunction with suitable software, this port allows the connected computer to continuously monitor the input mains voltage and UPS status, and display a message if there any UPS system changes.

The USB port on the customer interface board is connected in parallel with JD11 and output the same data stream.

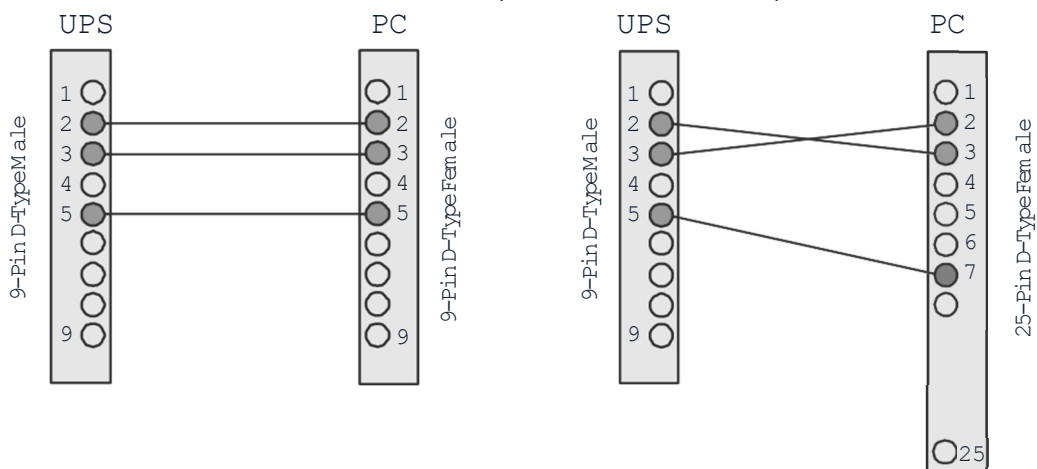

Figure 9.2 Connector Cable - PC Serial Port

### 9.2.2 Dry ports customer interface (X2, X3)

Customer I/O interface facilities are made to Phoenix spring terminal blocks (cable 0.5 mm<sup>2</sup> to 1.5 mm<sup>2</sup>). All voltage-free contacts are rated at 250VAC/8A, 30VDC/8A, 110VDC/0.3A, 220VDC/0.12A.

On the Master board the following ports are active:

- The Input ports (X2)
- The Output port (X3)

On the Slave boards the following parts are active.

- The Output ports X2
- All other input or output ports on the Slave boards are not activated

	Terminal	Contact	Signal	Display	Function
<b>INPUTS</b>					
<b>X3</b>	X3/14	Gnd	Gnd		Battery Temperature Sensing (If connected this input is battery temperature dependent)
	X3/13	In	+3.3V		
	X3/12	Gnd	Gnd	GENERATOR OPER ON	Customer Specific Input (1) (Default NC = Generator on line)
	X3/11	In	+12V		
	X3/10	Gnd	Gnd	Parallel Switch OPEN/CLOSED	External output circuit breaker (When used, both the external and the internal (IA2) output breakers have to be either open or closed in order to isolate or connect the UPS output.)
	X3/9	In	+12V		
	X3/8	Gnd	Gnd	EXT MAN BYP	External Manual Bypass (External IA1)
	X3/7	In	+12V		
	X3/6	Out	+12V		+12Vdc Power source (max 200mA load)
	X3/5	Gnd	Gnd		
	X3/4	Gnd	Gnd		
	X3/3	In	+12V	REMOTE SHUTDOWN	RSD Remote Shut Down Leave jumper JP5 in place if no Remote Shut Down input is connected
	X3/2			REMOTE SHUTDOWN	RSD Remote Shut Down (For external switch) Max 250VAC/8A, 30VDC/8A, 110VDC/0.3A, 220VDC/0.12A
X3/1					
<b>OUTPUTS</b>					
<b>X2</b>	X2/18	Com	Spare function		Common
	X2/17	NC			Auxiliary NO
	X2/16	NO			Auxiliary NC
	X2/15	Com	Alarm	COMMON ALARM	Common
	X2/14	NC			No Alarm Condition
	X2/13	NO			Common (System) Alarm active
	X2/12	Com	Status	LOAD ON MAINS	Common
	X2/11	NC			No Load On Bypass
	X2/10	NO			Load on Bypass (Mains) active
	X2/9	Com	Alarm	BATT LOW	Common
	X2/8	NC			Battery OK
	X2/7	NO			Battery Low active
	X2/6	Com	Status	LOAD ON INV	Common
	X2/5	NC			Load not On Inverter
	X2/4	NO			Load on Inverter active
	X2/3	Com	Alarm	MAINS OK	Common
	X2/2	NC			Mains Failure
	X2/1	NO			Mains Present
<b>CASTELL INTERFACE</b>					
<b>X1</b>	X1/2	230Vac	–	EXT MAN BYP	Castell Interlock Function External Manual Bypass closed (230VAC 2AT)
	X1/1	N	–		

Figure 9.3 Dry port connection details

### Remote shut down (emergency stop) option

On a standard UPS the remote shut down function is disabled; and if this option is required it must be activated by a hardware code on the **SETUP SERVICE** menu. Please contact your distributor to enable this operation.

The remote shut down facility comprises a normally-closed circuit connected between terminal X3/3 and X3/4 on the customer interface card located on the Rehiko PW 9500DPA front frame (see Figure 9.4).

If this option is used, it is recommended that a terminal block, with linking facilities, is installed between the UPS and the remote emergency stop button, as shown, in order to allow the removal, maintenance or testing of the remote emergency stop circuit without disturbing the normal UPS operation.

1. Use a screened cable with a single pair (0.5 mm<sup>2</sup> to 1.5 mm<sup>2</sup>) and maximum length of 100m.
2. Connect the cable as shown in Figure 9.4.

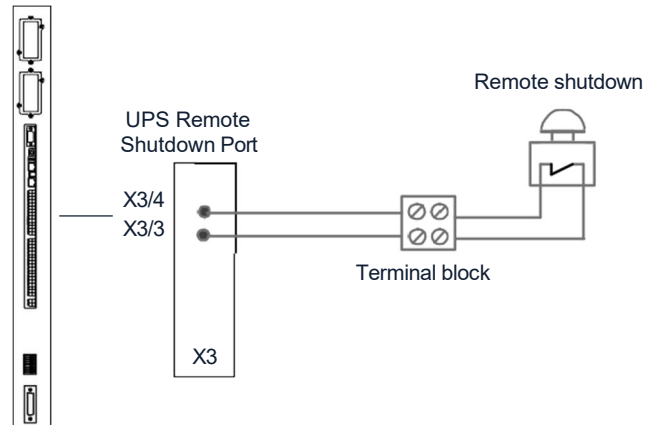

Figure 9.4 Remote emergency stop cabling



**Key Point:** In a single module installation the UPS is provided with an automatic 'emergency bypass' facility. In this case the standard remote shut down option is disabled and the remote shut down (emergency stop) operation must be designed into the external building/facilities system and include a means of opening the bypass path when operated.

### Generator ON facilities

The generator ON facility must use a normally-open contact which closes when a standby generator is running and supplying the UPS input power. This volt-free switched input can be used to inhibit the static bypass and battery charger whilst the UPS is being from the generator.

1. Use a screened cable with a single pair (0.5 mm<sup>2</sup> to 1.5 mm<sup>2</sup>) and maximum length of 100m.
2. Connect the cable as shown in Figure 9.5.

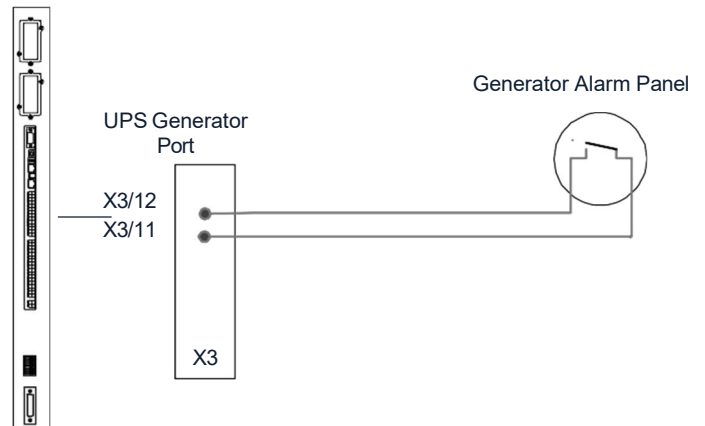

Figure 9.5 Generator ON Connection

### 9.2.3 RS485 Interface for multidrop – JR2

The optional 'Multidrop' feature, which is available only in a parallel system, allows the customer interface board in the master cabinet to collect data/messages from the other system cabinets via the cables connected to JD2. The received data is then processed at a centralised point on the 'master' customer interface board and made available to the user directly on the RS232 port (JD1). It is also transmitted to the SNMP/CS141 card if inserted in the relevant card-slot.



**Key Point:** When the multidrop feature is used the I/O facilities of customer interface boards in the 'slave' cabinets are all disabled, but the customer interface board fitted to the 'master' cabinet remains fully functional.

If the multidrop feature is requested, the commissioning engineer will install the required kit of parts and test the system to ensure it is fully functional as part of the UPS commissioning procedure.

### 9.2.4 RS485 Interface for remote panel – JR3

JR3 is used by the TFT touch-screen display and control unit.

### 9.2.5 SNMP Card slots

Simple Network Management Protocol (SNMP) is a world-wide, standardised communication protocol that can be used to monitor any network-connected device via a simple control language and display the results in an application running within a standard web browser.

The customer interface board contains two SNMP/CS141 slots; one is designed to house a Modem/Ethernet SNMP adapter card and the other a Modem/GSM adapter. SNMP connectivity can also be implemented using an external SNMP adapter connected to the UPS RS232 output (JD11), as shown in Figure 9.6.

The SNMP/Ethernet adapter is fitted with an RJ-45 connector which allows it to be connected to the network using a standard CAT-5 network cable. Once connected, the UPS-Management software agent installed in the SNMP adapter, then monitors the UPS operation and outputs its data in SNMP format to the connected network. In a multi-module UPS system the SNMP interface can communicate 'system-wide' data or data for an individual UPS module.

The SNMP adaptor requires a PC with terminal connections, and for normal operation at least one Ethernet connection. The SNMP card can be configured to send event/alarm emails, provide controlled server shut down (with optional licenses) and perform other tasks that can be integrated with BMS software over a local area network (LAN) for SNMP, or Modbus information over IP. An optional card is available to enable Modbus communications over RS485.

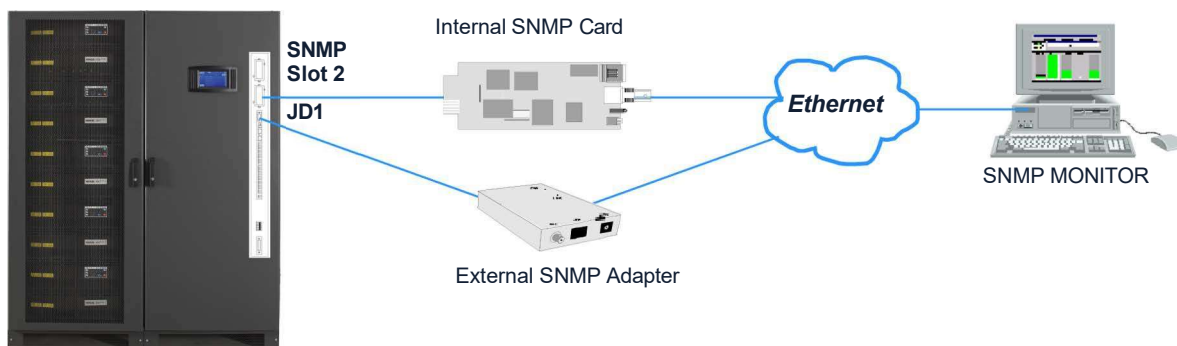

Figure 9.6 SNMP Internal and external adapters

## 9.3 UPS Monitoring and automated control software

### 9.3.1 The importance of UPS management

The utility supply is inevitably unreliable every now and then; and assuring continuous power to all the facilities connected to it can be a difficult task. The situation is further complicated if worldwide systems are managed via a Local Area Network (LAN) or Wide Area Network (WAN).

However, by using the Rehiko PW 9500DPA UPS system in conjunction with purpose-designed network management tools, a System Administrator can take measures to back-up data and prevent system errors or data loss even in the event of a relatively long utility supply outage. In the case of an abnormal utility supply, suitable UPS management software can also enable a System Administrator to monitor all concerned networks from a central point and identify bottlenecks at an early stage.

In spite of extensive system monitoring, serious damage can still occur if an administrator fails to intervene in a timely manner, and it is therefore important that the installed UPS software reacts automatically in such an event and shuts down the supplied system in a safe and controlled manner.

Rehiko considers it important to have a complete solution for its UPS systems, and offers its customers a number of remote control and monitoring tools to provide optimum protection.

### 9.3.2 PowerREPORTER™ management software

PowerREPORTER is a remote monitoring and management service which provides peace-of-mind protection by offering a continuous (24/7/365) watch over mission-critical facilities. Continuous monitoring is an affordable insurance policy to detect issues and provide an early warning before they develop into a crisis.

The main features and benefits offered by PowerREPORTER are:

- real time alarm or critical event email notification sent directly to Rehiko service centre
- acquisition of key performance data and productivity information to allow a better understanding of the UPS system performance and quickly troubleshoot downtime events
- improved service level. Combined with a service contract, PowerREPORTER ensures an engineer can determine if site attendance is necessary and bring relevant spare parts
- Monthly status report detailing trends and alarms

An optional battery analysis and care service; PowerNSURE - measures battery voltage, temperature, impedance and prolongs battery service life through the application of battery charge equalization.

### Functional description

PowerREPORTER communicates constantly with your UPS system to automatically detect any error or alarm messages. If it encounters an incident, PowerREPORTER will automatically transmit a status message, via email, to the Rehlko service centre providing details relating to the identified fault, a snapshot of the UPS performance parameters and a device identification string. The email automatically alerts the service centre personnel who then remotely diagnose the UPS incident and liaise with the company's field service team so that they can reach the facility with appropriate spare parts within the contracted service agreement time-frame.

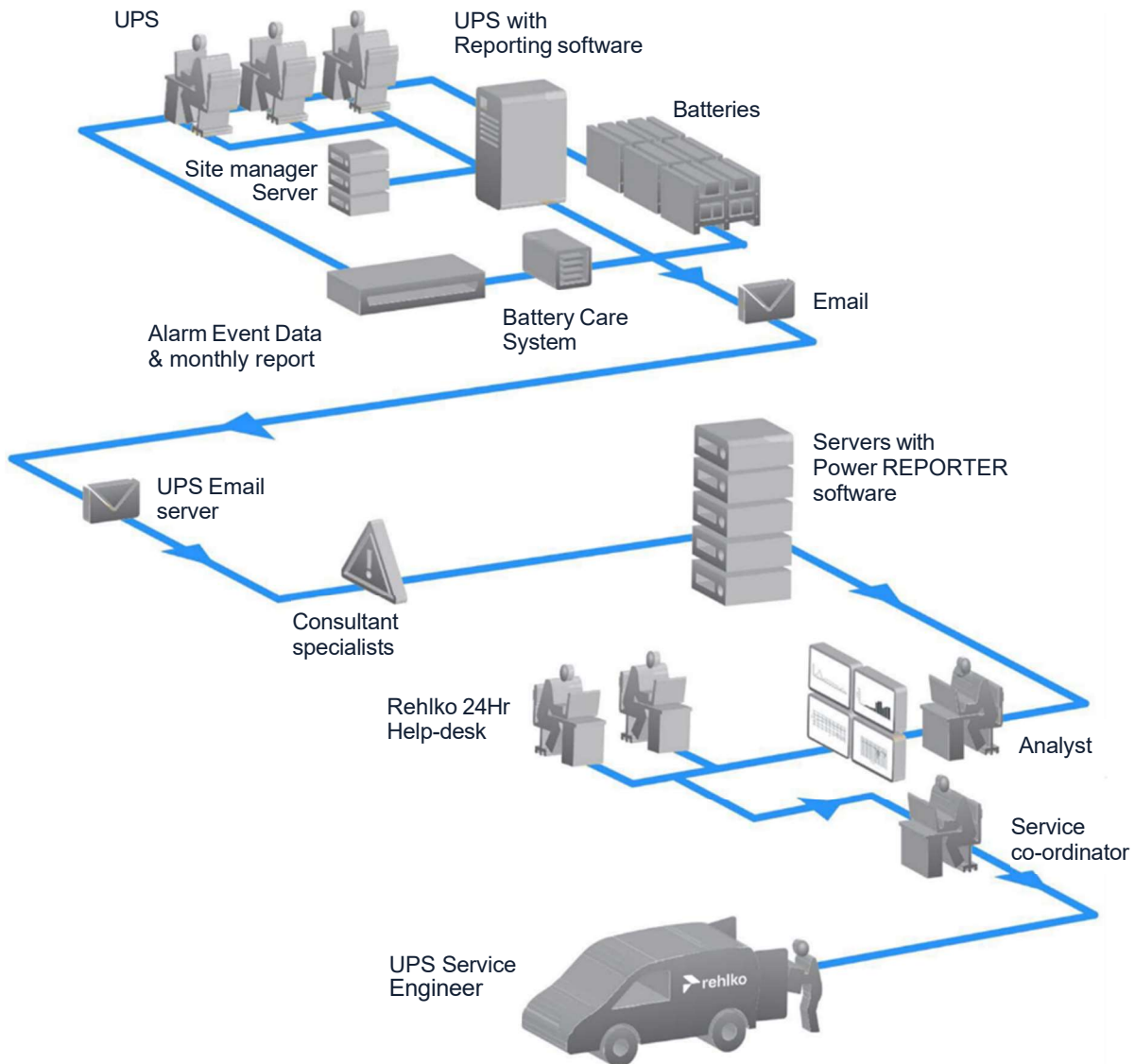

## 10. Specification

### 10.1 Introduction

This system comprises a cabinet that can be populated with up to five 100kVA power modules that operate in parallel within the cabinet to provide the cabinet's rated output. Each power module is a self-contained UPS and incorporates a rectifier, inverter and static bypass. Six of the cabinets shown can be connected together to form a 3 MVA parallel system.

### 10.2 Mechanical data

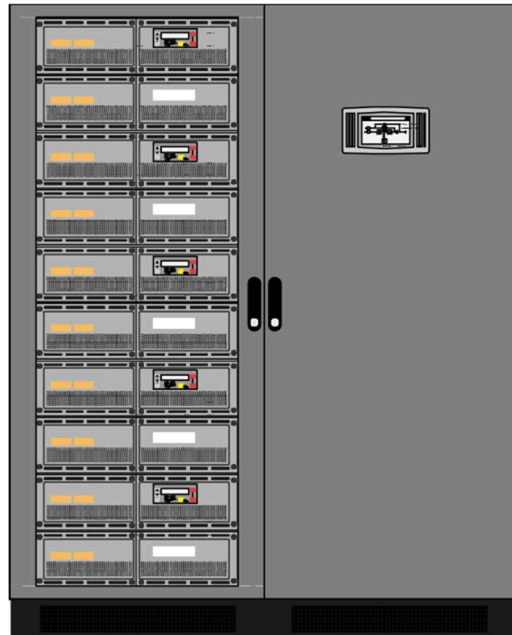

#### 10.2.1 UPS Cabinet



Maximum cabinet rating	500 kVA / 500kW (with 5 power modules fitted)
Dimensions (W x D x H) mm	1580 x 940 x 1975
UPS Type	On-line, transformerless, modular, decentralized parallel architecture
Parallel capability	Up to 6 frames (with up to 5 x 100 kVA modules in each frame)
Battery	Not included
Performance specification	VFI-SS-111
Weight	975 kg (with five power modules fitted)
Colour	Black (RAL 9005)
Positioning	Min. 300mm space required at the rear for ventilation Min. 1500mm space required at front for access Min. 400mm space required at the top for ventilation
Input/output power cabling	From the top or bottom

Remote signalling and alarms	
Dry port (volt-free contacts)	For remote signalling and automatic computer shutdown
Smart port (RS 232)	For monitoring and integration in network management
RS485 on RJ45 port	For multidrop purposes
SNMP card slot	For monitoring and integration in network management
Signalling input terminals	EMERGENCY OFF (normally closed) GENERATOR-ON (normally open) BATTERY TEMPERATURE SENSOR EXTERNAL BYPASS INTERLOCK

### 10.2.2 100 kVA UPS Power module

100 kVA UPS Power module		
		
	Active Sub-module	Passive Sub-module
Dimensions (W x H x D) mm	710 x 178 x 750	
Weight (kg)	55 kg (active module)	54 kg (passive module)
UPS Type	On-line, transformerless, modular, decentralized parallel architecture	

### 10.3 100 kVA UPS Module Data

General Data	
Output power factor	1.0
Output rated power @ 1.0 p.f.	100 kW
Output current I <sub>n</sub> @ 1.0 p.f.	145A (@400 V)
Efficiency AC-AC at various loads (at up to unity power factor)	Load: 100% 75.0% 50.0% 25.0% Eff: 95.6% 96.0% 96.1% 95.8%
ECO mode efficiency at 100% load	99% or better
Back feed protection	Standard
Rectifier Data	
Input voltage	3x380/220V+N, 3x400V/230V+N, 3x415/240V+N (Three phases, Neutral and Earth required)
Input voltage tolerance (ref to 3x400/230V) for loads in %	(-10% to +15%) for <100% load (-20% to +15%) for < 80% load (-30% to +15%) for < 60% load
Input frequency	35 Hz – 70 Hz (nominal 50/60 Hz)
Input power factor	PF=0.99 @ 100% load
Inrush current	<100% of rated current, limited by soft start
Input distortion THDI	<3.5% @ 100% load
Max. input current with rated output power and charged battery (output p.f. = 1.0)	152A
Max. input current with rated output power and discharged battery (output p.f. = 1.0)	167A
Inverter Data	
Output voltage (steady state rms)	3x380/220V or 3x400/230V or 3x415/240V (3 phase + Neutral)
Output voltage variation	± 1.5% (Normal and battery mode)
Output waveform	Sine wave
Output current (rms rated)	145 A
Output frequency	50 Hz or 60 Hz
Output frequency tolerance	Free running, quartz oscillator < ±0.1% Synchronized with mains < ±2% or < ±4% (selectable)
Permissible unbalanced load	100% (All 3 phases are regulated independently)
Phase angle tolerance	0 deg. (With 100% unbalanced load)
Inverter overload capability	110% load for 20 minutes; 125% load for 5 minutes; 150% load for 30 seconds.
Output short capability (rms)	(2.4 x I <sub>n</sub> ) A during 100 ms
Output voltage transient recovery time with 100% step load	Linear < ±4% Non linear < ±4% (EN62040-3)
Output voltage distortion (THD) @100% load (normal and battery mode)	< 2.0% With linear load < 4.0% With non linear load (EN62040-3)

Static Bypass Data	
Transfer time (inv-byp), (byp-inv), (Eco)	<1 ms, <5 ms, <6 ms
Rated current	160A
overload current	110% load continuous
Bypass short capability (RMS)	(10 x In) A during 20 ms

## 10.4 General Data

Environmental Data	
Audible noise at 100% / 50% load (fully populated cabinet)	75 / 67 dBA for normal (mains) operation. 73 / 66 dBA when operating on battery,
Operating temperature (UPS)	0°C to +40°C
Storage temperature (UPS)	-25°C to +40°C
Battery Temperature	+20°C (recommended for maximum battery life)
Relative air-humidity	Max. 95% (non-condensing)
Max. altitude (above sea level)	1000m (3300ft) without de-rating
Heat dissipation with 100% linear load	4500W, 15359 BTU/m per module (EN 62040-1-1:2003)
Heat dissipation with 100% non-linear load	5710W, 19488 BTU/m per module (EN 62040-1-1:2003)
Heat dissipation at no load	660 W per module
Airflow (25° - 30°C) with non-linear load	1200 m³/h per module (EN 62040-1-1:2003)

Battery data (external)	
Technology	VRLA, vented lead acid, NiCd, Li-Ion
Number of 12V blocks (even and odd number permissible) See note Limitation to runtime	40 to 50 @ 380/220V or 400/230V output 42 to 50 @ 415/240V output
Charger capability (each module)	60.0A
Ripple current (rms)	< 2.0%
Floating voltage	2.26 VDC (VLRA), 1.4 VDC (NiCd)
End of discharge voltage	1.65 VDC (VLRA), 1.05 VDC (NiCd)
Temperature compensation	Standard
Battery test	Automatic and periodic (selectable)

Communications options (fitted as standard)	
RJ45 Plug (Not used)	RJ45 Plug (for future options)
Customer interfaces: outputs DRY PORT X2	5 Volt-free contacts For remote signalling and automatic computer shut down
Customer interfaces: inputs DRY PORT X1	1 x Remote Shut-down [EMERGENCY OFF (normally closed)] 1 x Programmable Customer Inputs 1 x GEN-ON (normally open) 1 x Temperature sensor for battery charging control 1 x 12Vdc output (max 200mA)
Serial ports RS232 on Sub-D9	1 x System frame for monitoring integration in network management and service
USB	1x For monitoring and software management
Slot for SNMP card	For monitoring and integration in network management
Slot for Modem/Ethernet card	For monitoring and integration in network management
Remote signalling and alarms (fitted as standard)	
Dry port (volt-free contacts)	For remote signalling and automatic computer shut down
Smart port (RS 232)	For monitoring and integration in network management

RS485 on RJ45 port	For multi-drop purposes
SNMP card slot	For monitoring and integration in network management
Signalling input terminals	EMERGENCY OFF (normally closed) GENERATOR-ON (normally open) BATTERY TEMPERATURE SENSOR EXTERNAL BYPASS INTERLOCK
<b>Standards (UPS Modules)</b>	
Safety	EN 62040-1-1
Electromagnetic compatibility	EN 62040-2
Emission class	C2
Immunity class	C3
Performance	EN62040-3
Product certification	CE UKCA
Degree of protection	IP 20

### 10.4.1 Limitations to Runtime

At output voltage 415/240Vac 12V block minimum is 42

No. Batts (12V)	Temp (°C)	Load (%)	Max Runtime (mins)
50	25	100	10
48	25	100	15
46	25	100	30
44	25	100	Any
42	25	100	Any
40	25	100	20
50	35	90	10
48	35	90	15
46	35	90	30
44	35	90	30
42	35	90	30
40	35	90	20
50	40	80	10
48	40	80	15
46	40	80	30
44	40	80	30
42	40	80	30
40	40	80	20