



REHLKO *PW* 6000

Medium to high power three-phase uninterruptible power supply

(400–500 kVA)

User Manual

Document Control

ISSUE	DATE	REVISION SUMMARY
TS_835_01	21/08/2023	Rebranding to KUP International Version
TS_835_02	16/09/2024	Torque settings amended in chapter 3
TS_835_03	25/11/2025	Added power derating with reduced battery blocks
TS_835_04	02/06/2026	Rebranded to Rehlko, updated torque setting

Useful Contacts

UK

www.ups.rehlko.co.uk

ukservice.ups@rehlko.com

uktechnicalsupport.ups@rehlko.com

uksales.ups@rehlko.com

ukservicesales.ups@rehlko.com

Rehlko web site

Service department – booking service, fault reporting etc.

Technical queries

Hardware sales

Extended warranty agreements etc

IRELAND

www.ups.rehlko.ie

ieinfo.ups@rehlko.com

Rehlko web site

Service department, technical queries, hardware sales and extended warranty agreements

SINGAPORE

www.ups.rehlko.sg

salesups.sg@rehlko.com

serviceups.sg@rehlko.com

Rehlko web site

Hardware sales

Contract customer support, maintenance contracts renewals

All product, product specifications and data are subject to change without notice to improve reliability, function, design or otherwise. Rehlko has taken every precaution to produce an accurate, complete and easy to understand specification document and will assume no responsibility nor liability for direct, indirect or accidental personal or material damage due to any misinterpretation of, or accidental errors, in this manual.

© 2026 Rehlko

This document may not be copied or reproduced without written permission of Rehlko.

Contents

1. Safety	1
1.1 Description of symbols used in this manual	1
1.2 User precautions	1
2. General Description	2
2.1 Introduction	2
2.1.1 Reliability and quality standards	2
2.1.2 Key features	2
2.2 Rehiko PW 6000 (400-500kVA) model range	3
2.3 UPS module functional description	4
2.3.1 UPS module block diagram	4
2.3.2 UPS internal operating modes	5
2.3.3 System operating modes	7
2.4 Multi-module parallel system	8
2.4.1 Parallel system concept	8
2.4.2 Parallel control functions	8
2.4.3 Common battery	10
2.5 Module Control Panel (standard LCD)	11
2.5.1 Module mimic LED indicators	11
2.5.2 Operator buttons	12
2.5.3 Power Management Display (PMD)	13
2.6 TFT Module control panel	15
2.6.1 Display header bar	15
2.6.2 Mimic diagram screen	16
2.6.3 Home screen	17
2.7 Warranty	19
2.8 Extended Warranty	19
2.9 Contacting service	19
3. Installation Planning	20
3.1 Introduction	20
3.2 Taking receipt of the UPS	20
3.2.1 Reporting transportation damage	20
3.2.2 Local transportation	21
3.2.3 Storage	21
3.3 Unpacking	21
3.4 Planning the installation (environmental and mechanical)	21
3.4.1 Environmental considerations	21
3.4.2 UPS Cabinet installation	22
3.4.3 Top Cable Entry (TCE) extension cabinet installation	22
3.4.4 Battery installation	24
3.5 Planning the installation (cabling considerations)	24
3.5.1 General requirements	24
3.5.2 Parallel cabinet cabling recommendations	25
3.5.3 External maintenance bypass switch	27

3.5.4 Cable sizing	28
3.6 Electrical installation (cabling procedures)	29
3.6.1 Bottom entry cabling procedure	30
3.6.2 Top entry cabling procedure	33
3.6.3 Connecting the battery	36
3.7 Single/Dual feed conversion	37
3.8 Installation of remote monitoring and control facilities	38
3.8.1 Module communications interface facilities	38
4. Operating Instructions (LCD)	39
4.1 Introduction	39
4.1.1 Commissioning	39
4.1.2 Operating procedure summary	39
4.1.3 General warnings and precautions	40
4.2. How to start the UPS system from a fully powered-down condition	40
4.3 How to start the UPS system from the maintenance bypass	42
4.4 How to transfer the load to maintenance bypass	42
4.5 How to shut down the complete UPS system	43
4.6 Operating in bypass (ECO) mode	44
4.6.1 How to Turn ON the UPS system and operate in 'on bypass' (ECO) mode	44
4.6.2 How to Turn OFF the UPS system when operating in 'on bypass' (ECO) mode	44
4.6.3 How to transfer between 'on bypass' (ECO) and 'on inverter' mode	44
5. Operating Instructions (TFT)	45
5.1 Introduction	45
5.1.1 Commissioning	45
5.1.2 Operating procedure summary	45
5.1.3 General warnings and precautions	46
5.2 How to turn on the UPS system from a fully powered-down condition	47
5.2.1 Power-up the load on the maintenance bypass	47
5.2.2 Transfer the load to the static bypass line	48
5.2.3 Transfer the load to inverter	49
5.3 How to start the UPS system from the maintenance bypass	50
5.3.1 Power up the UPS system	50
5.3.2 Transfer the load to the static bypass line	51
5.3.3 Transfer the load to inverter	51
5.4 How to transfer the load to the maintenance bypass and turn OFF the UPS	51
5.4.1 Transfer the load to the static bypass	52
5.4.2 Transfer the load to the maintenance bypass	53
5.4.3 Turn OFF the UPS	53
5.5 How to shut down the complete UPS system	53
5.6 Operating in bypass (ECO) mode	54
5.6.1 How to Turn ON the UPS system and operate in (ECO) mode	54
5.6.2 How to transfer the load to the maintenance bypass and Turn OFF the UPS system	54
5.6.3 How to transfer between 'on bypass' (ECO) and 'on inverter' mode	54

6. Maintenance	55
6.1 Introduction	55
6.2 User responsibilities	55
6.3 Battery testing	55
7. Troubleshooting	56
7.1 Alarms	56
7.2 LCD Control panel	56
7.3 TFT Control panel	56
7.4 Troubleshooting table	57
7.5 Contacting service	57
8. Options	58
8.1 Introduction	58
8.2 Serial RS232 Computer interface – USB & JD1 (Smart Port)	59
8.3 RS485 Interface for multidrop – JR2	59
8.4 Dry ports customer interface (X1, X2)	60
8.4.1 Dry port connections	60
8.4.2 Remote Emergency Power Off (EPO) option	61
8.4.3 Generator ON facilities	61
8.5 SNMP Card slots	62
9 Specification	63
9.1 General Specifications	63

1. Safety

1.1 Description of symbols used in this manual



WARNING: The warning symbol is used where there is danger of an electrical shock, equipment damage or personal injury.



CAUTION: The caution symbol is used to highlight important information to avoid possible equipment malfunction or damage.

1.2 User precautions



WARNING: Keep this manual with the UPS for future reference.



WARNING: The UPS and peripheral equipment must be installed and commissioned by suitably qualified and trained personnel who are aware of the potential shock hazards.



WARNING: Do not attempt to install this UPS system until you are satisfied that ALL the safety instructions and hazard warnings contained in this manual are read and fully understood.



WARNING: High leakage current!

Ensure that the UPS has been correctly earthed before you connect the mains power supply!



WARNING: This UPS must not be started-up or put into use without having first been commissioned by a fully trained engineer authorised by the manufacturer.



WARNING: This UPS must be serviced by qualified personnel.

You run risk of exposure to dangerous voltages by opening or removing the UPS-covers! Rehiko will assume no responsibility nor liability due to incorrect operation or manipulation of the UPS.



WARNING: The Rehiko PW 6000 (160-300kVA) is a Class A UPS product (according to EN 62040-3). In a domestic environment the UPS may cause radio interference. In such an environment the user may be required to undertake additional measures.

2. General Description

2.1 Introduction

Congratulations on your purchase of the Rehiko PW 6000 (400-500kVA) UPS.

Continuous power availability is essential in today's dynamic IT and process-related work environments. It is equally important that any installed power protection system is sufficiently resilient and adaptable to handle any requirement changes brought about by the introduction of new server technologies, migration and centralization.

Such demands are well met by the Rehiko PW 6000 (400-500kVA) UPS system, which provides the foundation for continuous power availability of network-critical infrastructures both in enterprise data centres, where business continuity has paramount importance, and in process control environments, where manufacturing continuity is essential.

2.1.1 Reliability and quality standards

The Rehiko PW 6000 (400-500kVA) UPS is available over a model range of 400kVA to 500kVA and incorporates the latest technological developments in power engineering. Representing a completely new generation of high power three phase UPS systems, its advanced double conversion VFI (Voltage and Frequency Independent) topology responds fully to both the highest availability and environmentally friendly requirements compliant with IEC 62040-3 (VFI-SS-111) standards.

Rehiko specialises in the installation and maintenance of Uninterruptible Power Systems; and this powerful UPS is just one example of our wide range of state-of-the-art power protection devices that will provide your critical equipment with a steady and reliable power supply for many years.

2.1.2 Key features

High reliability, upgrade-ability, low operating costs and excellent electrical performance are just some of the highlights afforded by this innovative UPS solution. Other key features include:

- *Compact size, small foot print – Saving on expensive floor space*
- *Flexible battery management – Advanced management of battery charging and preventive failure diagnostics avoids premature deterioration of battery life*
- *Best in class AC-AC efficiency, up to 96% – Saving on energy and operational cost (TCO)*
- *Low input power factor (near unity) – Saving cabling and supply distribution costs during installation and the over the entire life cycle (TCO)*
- *Blade-server-friendly power – Full power available from 0.9 lead to 0.9 lag means that no de-rating is required with leading power factor loads and therefore no need to 'over-size' the UPS system to cater for the load.*
- *Very low input current distortion THDi – The THDi is $\leq 3.5\%$ @ 100% load, reducing the capital and installation costs of an optional standby generator if used.*
- *Ease of expansion – Additional UPS cabinets (up to a maximum of 10) can be connected to an existing parallel system without needing to disturb the load supply*

2.2 Rehiko PW 6000 (400-500kVA) model range

The Rehiko PW 6000 (400-500kVA) UPS line-up includes models ranging from 160 kVA up to 500 kW. This manual is specific to the 400 kW and 500 kW models. A detailed specification can be found in Chapter 8.



MECHANICAL DETAILS		STANDARD		+ TOP CABLE ENTRY (TCE) CABINET	
		2.25	500 kW	400 kW	500 kW
					
Rated output power	kVA/kW	400/400	500/500	400/400	500/500
Cabinet dimensions (w x h x d) (With elevation kit)	mm	1650 x 1994 x 850 (1650 x 2094 x 850)		2150 x 1994 x 850 (2150 x 2094 x 850)	
Weight	kg	950	1000	950+115	1000+115
Weight (TCE + single feed cables)	kg			950+245	1000+24
Weight (TCE + dual feed cables)	kg			950+285	1000+285

Figure 2.1 Rehiko PW 6000 (400-500kVA) Model range

A key-lockable door is fitted to the front of the cabinet to provide controlled access; and within the cabinet all the major power components are housed behind secured safety panels to further reduce the risk of accidental electrical shock.



WARNING: If you remove a safety panel you will be exposed to a sever shock hazard.

The safety panel panels should be removed only by a Rehiko trained engineer.

The Rehiko PW 6000 (400-500kVA) UPS can be used as a single, stand-alone UPS module or up to ten modules can be configured to operate as a parallel UPS system. A multi-module system is designed to increase the UPS system's output capacity and enhance the system's reliability by providing module redundancy.

Note: In this manual the terms 'multi-module system' and 'parallel system' are synonymous.



Key Point: ALL the UPS modules connected as a parallel system must have the same output rating, For example, it is not permissible to connect 400 kW and 500 kW UPS module together in a parallel system.

2.3 UPS module functional description

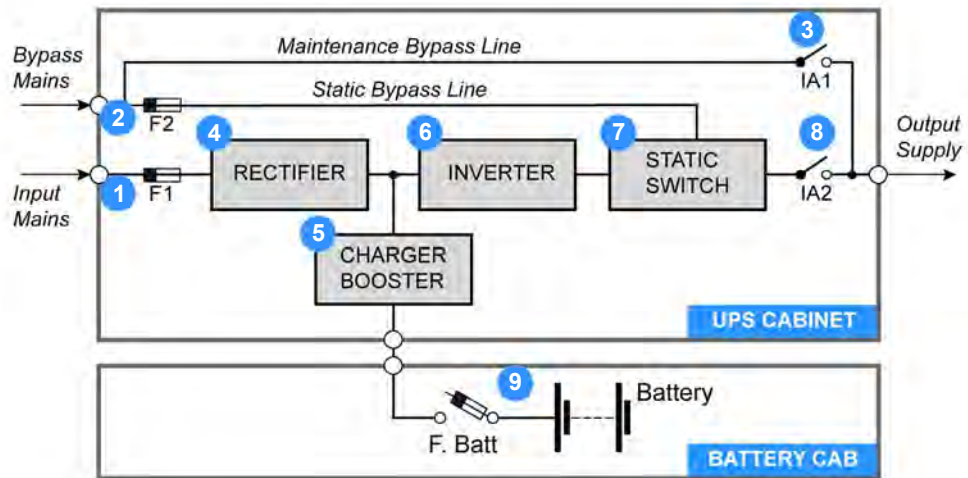

Figure 2.2 Rehko PW 6000 (400-500kVA) UPS module block diagram

2.3.1 UPS module block diagram

Figure 2.2 shows the major power blocks contained within the UPS system.

UPS Input supplies (1), (2)

The UPS is connected to two, 3-phase supplies, the ‘input mains supply’ and ‘bypass mains supply’. The input supply cables must be protected by an external isolation device (fuse/circuit breaker) to provide a means of disconnecting the mains supplies to the UPS. In practise, the bypass mains supply terminals are often linked to the input mains supply terminals within the UPS cabinet so the UPS cabinet only requires one mains supply connection – see paragraph 3.5.1 for details concerning ‘single feed’ & ‘dual feed’ input configurations.

Within the UPS cabinet the mains supplies are switched by isolators IA3 and IA4.

Maintenance bypass switch (3)

A maintenance bypass switch (IA1) provides a means of entirely bypassing the UPS power blocks and can be used to temporarily connect the load to the bypass mains supply if it is necessary to fully power down the UPS module for test/ repair purposes. Note that the maintenance bypass switch is only rated for the individual cabinet’s load, so where two or more cabinets are connected together to form a parallel system the internal maintenance bypass switch (IA1) should not be used. In a parallel system an external maintenance bypass facility must be incorporated into the system design which includes a system-rated maintenance bypass switch – a typical installation is shown on page 27.

Rectifier (4)

The rectifier converts the input mains supply to a DC power source that can satisfy the full inverter DC power demand over an input mains voltage range of -23% to +15%. This wide input voltage range means that the battery is not called upon during substantial power dips (brown outs), which helps maximise the battery life and availability. The rectifier control system uses leading-edge switched-mode techniques which achieves a UPS input power factor of almost unity over its operating range (0.99 at full rated linear load).

Battery booster/charger (5)

This block has bi-directional functions. When the UPS mains input supply is available, and the rectifier is turned on, the booster/charger acts as a multi-stage battery charger which uses an intelligent charging profile to optimise the battery life and ensure the battery recharges quickly following a deep discharge cycle.

When the UPS is operating from battery power the booster/charger boosts the battery voltage to provide a regulated DC input to the inverter to allow the inverter to operate correctly from battery power as the battery discharges.

Inverter (6)

The inverter converts the DC voltage produced by the rectifier (or the battery via the booster/charger) into a sinusoidal AC output voltage suitable to connect to the load. In addition to providing output voltage regulation, the inverter control logic also provides various levels of overload protection, frequency regulation and synchronisation, and output voltage error detection.

Static switch (7)

The static switch provides a means of connecting the UPS output to the inverter or static bypass line. The static switch control logic transfers the UPS output from the inverter to the static bypass line without a load-break in the event of an output overload or UPS (inverter) malfunction.

Parallel isolator, IA2 (8)

IA2 is a manually-operated switch that is connected between the static switch and the UPS output supply terminals. In a single-module installation IA2 can be used to isolate the UPS power electronics to enable repair/replacement procedures to be carried out while the load is connected to the maintenance bypass line, via IA1. In a 'redundant' parallel system IA2 can be similarly used to isolate a UPS module from the parallel system while the remaining modules continue normal operation.

Battery (9)

The UPS batteries are either installed in a dedicated battery cabinet or on a purpose-designed battery rack. The battery installation is bespoke but it must include a fuse located near the battery source to enable the batteries to be disconnected from the UPS. A range of external battery cabinets is available from Rehiko on request.

2.3.2 UPS internal operating modes

The following simplified block diagrams illustrate various UPS operating modes.

Load on Inverter

ON INVERTER is the normal UPS operating mode and is the only one that provides the load with continuously processed and backed-up power.

In this mode, the power rectifier converts the AC input mains supply to DC which provides the operating power for the inverter and charges the battery via the charger/booster. The inverter then converts its DC input to a controlled AC output that is suitable to supply the load.

The 'inverter side' of the static switch is closed and connects the inverter AC output to the output supply terminals via the closed parallel isolator switch (IA2).

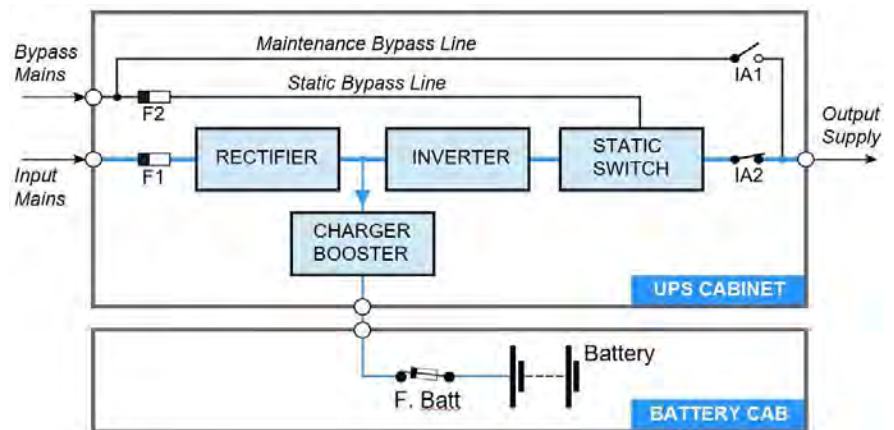

Figure 2.3 Load on inverter

When operating in the ON INVERTER mode, the inverter output frequency is synchronised to the bypass supply provided the bypass supply frequency remains within preset limits (normally ± 1 Hz). If the bypass supply fails altogether, the inverter frequency is controlled by a free-running oscillator that will maintain the output frequency at a constant 50/60Hz.

Load on Battery

If the input mains supply fails, or falls outside its preset voltage window, the rectifier shuts down and the battery provides an alternative DC power source for the inverter – which continues to operate until the battery is fully discharged.

When the battery is on load, a 'low battery' alarm is generated when the battery voltage falls to a preset level. This warns the operator to shut-down the load in an orderly manner if necessary (e.g. to save data) before the battery eventually reaches its end-of-discharge voltage and the UPS unavoidably shuts down. Various options are available to automate the load shut-down process, as described in the Options section of this manual.

In practice, especially in larger UPS installations, the UPS system often incorporates a standby generator which starts automatically in the event of a mains failure and provides an alternative UPS input supply source. In this scenario the battery is only required to support the inverter (load) until the generator comes on-line and, as a modern generator can be automatically started very quickly, this results in a relatively short battery discharge period – which helps to prolong the battery life.

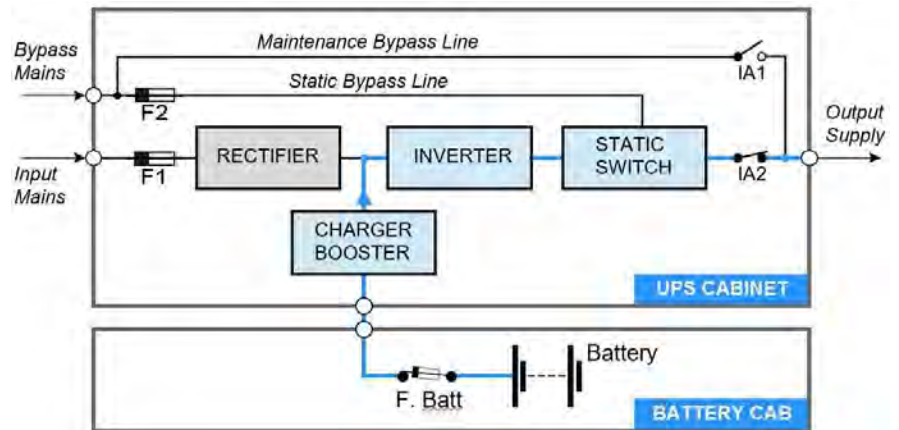

Figure 2.4 On battery

Load on-bypass

When operating in the ON BYPASS mode the UPS output is connected to the unprocessed static bypass line via the 'bypass side' of the static switch.

This mode can be manually selected from the UPS control panel and it is invoked automatically during UPS overload conditions or in the event of an inverter fault.

Depending on circuit conditions, when operating in this mode the rectifier and charger sections can be turned off entirely or remain running and continue to provide battery charging. Similarly, the inverter can also remain in an operating (standby) state ready to be brought back into use.

Note: This is the normal operating mode when using the UPS in ECO mode.

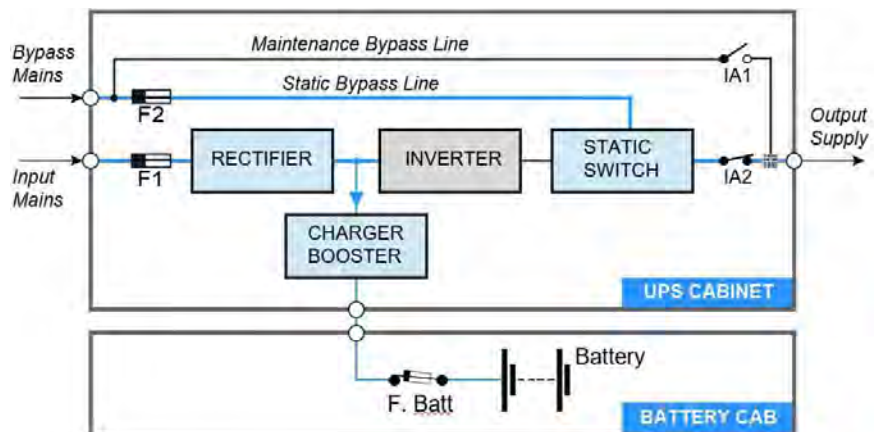

Figure 2.5 Load on bypass

Load on maintenance bypass

The manually closed maintenance bypass switch (IA1) connects the UPS output directly to the bypass mains supply. In a parallel system IA1 is not fitted in the UPS modules and is replaced by a 'system' maintenance bypass switch located in an external facility

To prevent possible inverter damage, it is important that the inverter output and maintenance bypass lines are never connected in parallel. Therefore the UPS control system includes a safety interlock to ensure that when transferring from the ON INVERTER mode to ON MAINTENANCE BYPASS mode the load is first transferred to the static bypass (ON BYPASS mode) before the maintenance bypass switch is closed.

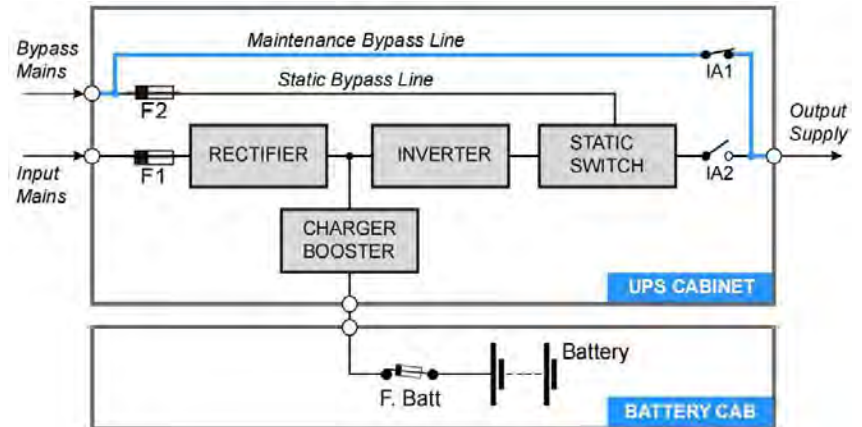

Figure 2.6 Load on maintenance bypass



CAUTION: Always follow the operating instructions in Chapter 4 of this manual when starting or shutting down the UPS.

2.3.3 System operating modes

Paragraph 2.3.2 described the various UPS internal operating modes: but UPS systems are also categorised according to the way in which they operate at a 'system' level, and are typically described as being either an 'on-line', 'off-line' or 'line interactive' UPS system. The Rehiko PW 6000 (400-500kVA) can be operated in all three of the above categories.

On-line operation

When used as an 'on-line' UPS the Rehiko PW 6000 (400-500kVA) module is configured to normally operate in the ON INVERTER mode.

In the unlikely event of an inverter fault, or during an overload, the UPS will transfer the load to the static bypass (ON BYPASS mode) automatically and without interruption (transfer time = 0). If the transfer is due to an output overload the system will transfer back to the ON INVERTER mode if the overload clears and the UPS will return to its normal operation.

Operating in the 'on-line' mode offers the greatest degree of load protection, especially in the event of a mains disturbance or failure, and is always recommended if the critical load will not tolerate even a very brief supply interruption.

Off-line (line interactive) operation

When the Rehiko PW 6000 (400-500kVA) is used in an 'off-line' or 'line-interactive' system the UPS module(s) normally operated in the ON BYPASS mode, with the load being supplied from the static bypass supply. However, the rectifier and battery charger are still powered up to maintain battery charging and the inverter is turned on but operating on standby.

In the event of a bypass supply error, or total failure, the load is automatically transferred to the inverter (ON INVERTER) by the static switch within 3 to 5 milliseconds. If the input mains supply is unavailable when the transfer takes place the inverter will support the load operating from battery power (ON BATTERY), as described above. If the bypass supply then returns to normal the load is transferred back to the static bypass and the inverter returns to standby.

This mode of operation is slightly more energy efficient than the 'on-line' mode due to the reduced rectifier/inverter losses during normal operation; and it is sometimes referred to as the "ECO" mode. However this mode is recommended only if the connected load equipment can tolerate power interruptions of 3 to 5 ms during the transfer period.



WARNING: The on-line system mode should always be used for critical load protection.

2.4 Multi-module parallel system

2.4.1 Parallel system concept

The outputs from up to ten Rehiko PW 6000 (400-500kVA) UPS modules can be connected together to form a parallel UPS system – an example of a three module parallel system is shown in Figure 2.7.

The Rehiko PW 6000 (400-500kVA) has a Decentralised Parallel Architecture (DPA), in that each UPS module contains its own static bypass and static switch. This eliminates the need for a separate bypass cabinet, which avoids a single point of failure that can exist in other, more traditional, parallel systems; and also allows an individual module to be electronically disconnected from the parallel system without affecting the remaining on-line modules.

A parallel module system offers system expandability and module redundancy, as described below:

System expansion

Most data centres present a low initial power demand which increases as the data centre grows to its full capacity; and it is essential that any installed power protection system can be expanded to meet a growing demand without compromising the existing load. This situation is easily managed in a Rehiko PW 6000 (400-500kVA) multi-module installation which allows additional modules to be connected to an existing parallel system without having to disrupt the load during the upgrade process.



Key Point: If a Rehiko PW 6000 (400-500kVA) module is purchased as a stand-alone, single module UPS it will require a field upgrade to make it suitable for parallel operation at a later time. For this reason, if you know that your load is likely to expand in the future it is advisable to install a parallel-capable module at the outset.

Module redundancy

A multi-module system designed with module redundancy contains at least one UPS module over and above that required to provide the specified system full load power.

For example, if the system shown in Figure 2.7 comprised 3x 400 kW modules it can be employed as a redundant module system for a load of 800 kW. In this case under, normal circumstances each module shares the load equally and supplies up to 266 kW at full load; but if one module fails, or is shut down, the two remaining modules can sustain the full rated load by each supplying 400 kVA. The ability to lose one module yet still supply the full load with processed, backed-up power significantly increases the overall system reliability.

2.4.2 Parallel control functions

In a multi-module parallel system the topology and internal operation of each UPS module is identical to that described previously for a stand-alone module. However, when operating as part of a parallel system an additional control layer is required to cater for critical 'system level' control functions such as load sharing, frequency synchronisation and load transfer, that must be observed by all the on-line UPS modules. This is achieved by connecting a 'parallel control bus' between the individual UPS modules to allow them to communicate with each other and execute all necessary synchronous control operations.

Inter-module frequency synchronisation and load sharing

Using sensing signals passed over the parallel control bus, each UPS module can compare its own frequency and output current with that of its neighbouring module. This allows each module's control logic to carry out the fine adjustments necessary to achieve balanced conditions.

The parallel control logic always observes one of the modules as being the 'master' and the other module(s) as 'slaves'. However, if the 'master' module goes faulty at any time the next module in the chain (a former 'slave') will immediately take over the role of master, and the former master module will turn off. The master/slave relationship is configured during commissioning.

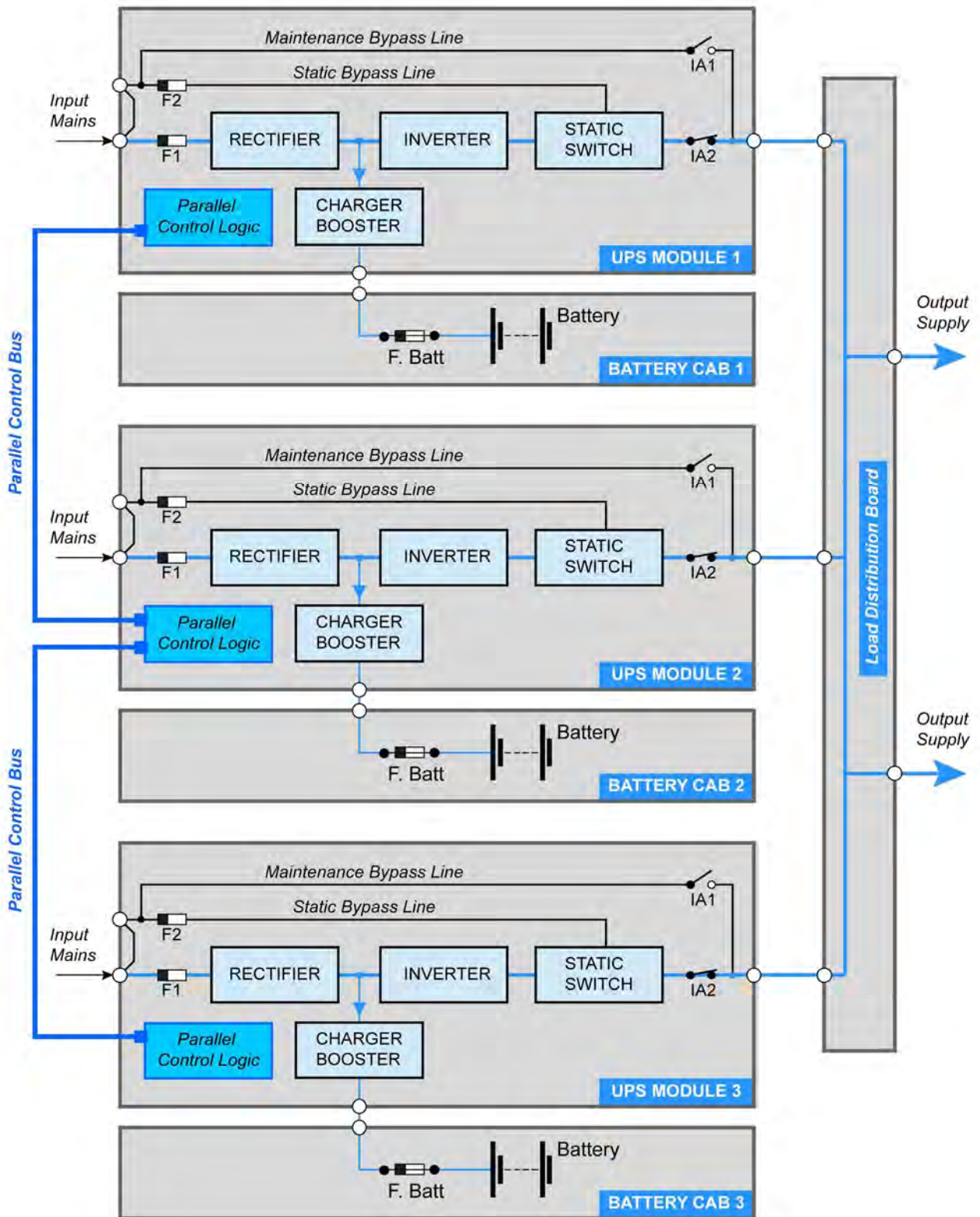

Figure 2.7 Rehiko PW 6000 (400-500kVA) UPS Parallel system

System-wide load transfer operation

All the modules that are connected to the load must be in an identical operating mode – i.e. it is not permissible for one module to operate in the ON INVERTER mode while the other modules are ON BYPASS, as such a situation would almost certainly damage the module(s). Therefore, if you activate the LOAD TO BYPASS command on *any one module* then all the modules will simultaneously switch to the ON BYPASS mode. Conversely, when operating on bypass if you select the command LOAD TO INVERTER on any one module then all the UPS modules will simultaneously transfer the load to their inverters – provided a sufficient number of modules are available to satisfy the system redundancy requirements.

Isolating a module from the system

If a parallel system incorporates module redundancy, a module can be isolated from the system for service/repair purposes without affecting the operation of the remaining modules or load.

Every module has a parallel (output) isolator (IA2) which can be used to isolate the module from the load bus. When IA2 is open there is no load power being drawn from the module and it can be shut down in the normal way using the ON/OFF controls on the UPS control panel; this will shut down the associated module only and will not cause the remaining modules to shut down or transfer the load to bypass.



WARNING: When the UPS module is shut down its output terminals will be live unless its external output isolator is opened.

2.4.3 Common battery

Although Figure 2.7 shows a separate battery installation connected to each UPS module, it is permissible to connect two or more modules to a common battery to allow them to share the battery charging. However by employing a separate battery bank for each module you avoid a potential single point of failure and increase the overall reliability by extending the system redundancy to include the batteries. We highly recommend the use of individual batteries for each module.

2.5 Module Control Panel (standard LCD)

The standard Rehiko PW 6000 (400-500kVA) module is controlled and monitored through an LCD-based module control panel located on the front of the cabinet. An alternative TFT touch screen, described in paragraph 2.6, is available.

By means the module control panel the operator can:

- Stop and start the UPS module
- Transfer the UPS output (load) between the inverter and bypass
- Monitor the UPS input/output voltage, current and frequency
- Monitor the battery charge/discharge voltage and current
- Monitor the battery status and autonomy time
- Interact with alarm and warning messages
- Configure the UPS operating parameters (service mode)*
- Interrogate the UPS events and alarm history (service mode)*
- Carry out diagnostic actions (service mode)*
- * *Service mode features are for trained engineer use and password protected*

The module control panel is composed of four parts, shown below:

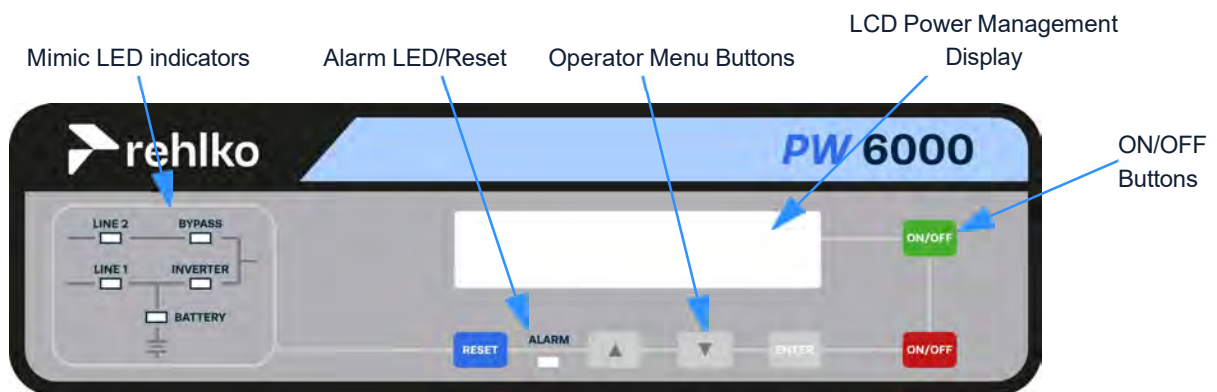

Figure 2.8 LCD Control panel

2.5.1 Module mimic LED indicators

The module mimic LEDs change colour between GREEN, RED and OFF to indicate the operational status of key UPS stages and thereby serve to show the active power path through the UPS.

- LINE 1 (rectifier) and LINE 2 (bypass) LEDs indicate the availability of the input mains and bypass mains supplies respectively.
- INVERTER and BYPASS LEDs illuminate green to indicate which of the two sources is supplying the UPS output.
- BATTERY illuminates green when the battery is being charged and flashes when the battery is discharging – e.g. when supplying the load following a mains failure. The indications change to red when the battery is faulty or fully discharged.
- The ALARM LED, located at the bottom centre of the control panel, provides a visual indication that an internal or external alarm condition has been detected. When an alarm condition is activated the LED is accompanied by an audible alarm.

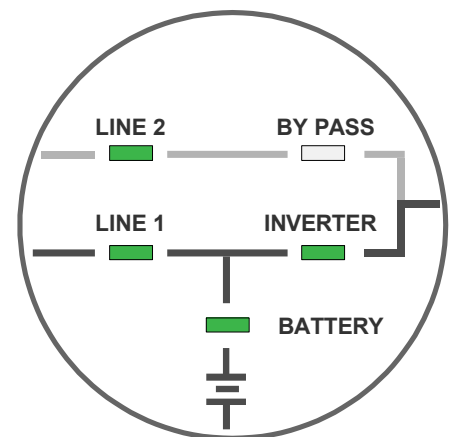

Figure 2.9 Module mimic diagram

LED Indication summary

INDICATOR	STATUS	INTERPRETATION
LINE 1	GREEN RED	Input Mains available Input Mains not available (Normal display during an input mains power failure)
LINE 2	GREEN RED	Bypass Mains OK Bypass Mains not OK (Bypass not present or bypass voltage / frequency error)
ALARM	OFF Flashing RED + buzzer RED	No alarm condition Alarm condition Alarm condition (has been reset)
INVERTER	OFF GREEN RED	Inverter turned OFF or load on bypass Load on inverter Inverter in unavailable, or locked out
BYPASS	OFF GREEN RED	Bypass not operating (Module is OFF or load on inverter) Load on bypass Static bypass is unavailable, or locked out
BATTERY	GREEN Flashing GREEN RED Flashing RED	Battery charger is ON and the battery is OK Load on battery and battery is discharging (Normal display during input mains failure) Battery faulty or discharged (High voltage, high temperature, failed battery test) Battery not detected. Battery is disconnected or fuse open, low battery voltage, (Note this is the default status before turning on the module).

2.5.2 Operator buttons

The operator buttons allow the user to:

- Set operating parameters and make adjustments via the menu-driven LCD display
- Start and stop the UPS, and transfer the load between inverter and bypass
- Select the UPS operating voltages, currents, frequencies and other parameters to monitor on the LCD display

Button function summary

BUTTON	FUNCTION
ON/OFF ON/OFF	Used to switch-on or switch-off the UPS
UP(▲)	Scroll upwards through a displayed menu
DOWN(▼)	Scroll downwards through a displayed menu
RESET	Cancels the audible alarm. If the alarm condition was transient the ALARM LED will also extinguish, otherwise the LED will remain ON (red)
ENTER	Confirms (selects) a chosen menu item

ON/OFF Buttons

The UPS can be switched ON or OFF by simultaneously pressing both ON/OFF buttons. The requirement to press both buttons is to help avoid accidental operation.

During normal operation, pressing the two ON/OFF buttons simultaneously will immediately shut down the UPS.

- In a single module installation this will disconnect the UPS output unless the load is first transferred to the maintenance bypass (see operating instructions).
- In a parallel module system the UPS module will shut down and its output will be disconnected from the parallel load bus. However, the load may or may-not transfer to bypass depending on whether or not the number of remaining live modules satisfies the system's redundancy – i.e. if there are a sufficient number of modules remaining to support the system load then the load will not be transferred.

To shut down all the modules in a parallel system you must press both ON/OFF buttons on every module.

2.5.3 Power Management Display (PMD)

Working in conjunction with the UP, DOWN and ENTER buttons, the LCD panel presents a range of menus to provide a simple interface for the user to operate the UPS module and monitor its performance – see Figure 2.11.

By default, during operation the LCD will display a UPS status screen similar to those shown below. From the status screen you can access the 'top level' control menu by pressing the UP or DOWN button; and from there you can further access any the nested sub-menus using the UP or DOWN buttons to scroll, and the ENTER button to make a selection.

Status screens

This status screen indicates that the UPS is operating 'on inverter' and providing protected power to the load.

LOAD PROTECTED	P01
-------------------	-----

This status screen indicates that the UPS will not support the load during a power failure, examples include 'on bypass' or batteries disconnected

LOAD NOT PROTECTED	P01
-----------------------	-----

This status screen indicates that the load is not being powered from the UPS, usually because the UPS has been switched off by the ON/OFF buttons.

LOAD OFF SUPPLY FAILURE	P01
----------------------------	-----

This status screen indicates that the UPS parallel switch (IA2) is open and the UPS module is disconnected from the parallel system. Although in a redundant parallel system the load might still be receiving protected power from the remaining on-line modules.

LOAD DISCONNECTED PARALLEL SWITCH OPEN	P02
---	-----

On the right hand side of the LCD-Display is a three digit indicator which shows the module's position in a multi-module system (maximum number of modules is 10).

- S Stands for **S**ingle unit. The UPS system comprises only one cabinet.
- P01 Stands for **P**arallel system and 01 identifies the cabinet as the 1st module (MASTER) in the system.
- P02 Stands for **P**arallel system and 02 identifies the cabinet as the 2nd module (SLAVE) in the system. This number can range from 02 to 10 depending on the cabinet's position in the parallel system.

Top level menu

The following sub-menus can be accessed from the top level menu:

EVENT LOG – The event log stores the last 64 UPS events in date/time stamp order. These include both 'fault' events, such as [OVERLOAD], and 'operational' events such as [LOAD TO BYP.].

MEASUREMENTS – This sub menu provides access to a range of input, output and battery parameter metering. – the battery voltage and current is monitored in two halves with respect to the battery string centre point. The positive (+) and negative (-) indications should be equal if the battery/charger is healthy.

COMMANDS – This sub menu provides access to a range of commands that might be used during day-to-day UPS operation. Those most commonly accessed are the [LOAD TO INVERTER] and [LOAD TO BYPASS] command which are used to transfer the load between inverter and bypass during the UPS start-up and shut down procedures.

[PERFORM BATT. TEST] Stops the charger and monitors the off-load battery voltage for 1 min. then transfers the load to battery for a further 1 min.

[PERFORM DEEP BATT. TEST] As above, but runs with battery on load until the low voltage alarm activates.

SET-UP DATA – This is a read-only menu and shows the UPS details input by the manufacturer/commissioning engineer.

[DYNAMIC PASSWORD] is normally set to NO

SET-UP USER – This sub menu allows the user to select the LCD display language, set the local date/time used to stamp the Event Log, set up the automatic battery test operation and configure the UPS options when running on standby generator.

SET-UP SERVICE – This manual is used by the commissioning engineer and is password-protected to restrict access.

[SET GENERATOR OP.].[BATT CHARGE LOCK] turns off the battery charger when the UPS is operating on generator.

[SET GENERATOR OP.].[BYPASS LOCK] inhibits load transfer to bypass when the UPS is operating on generator.

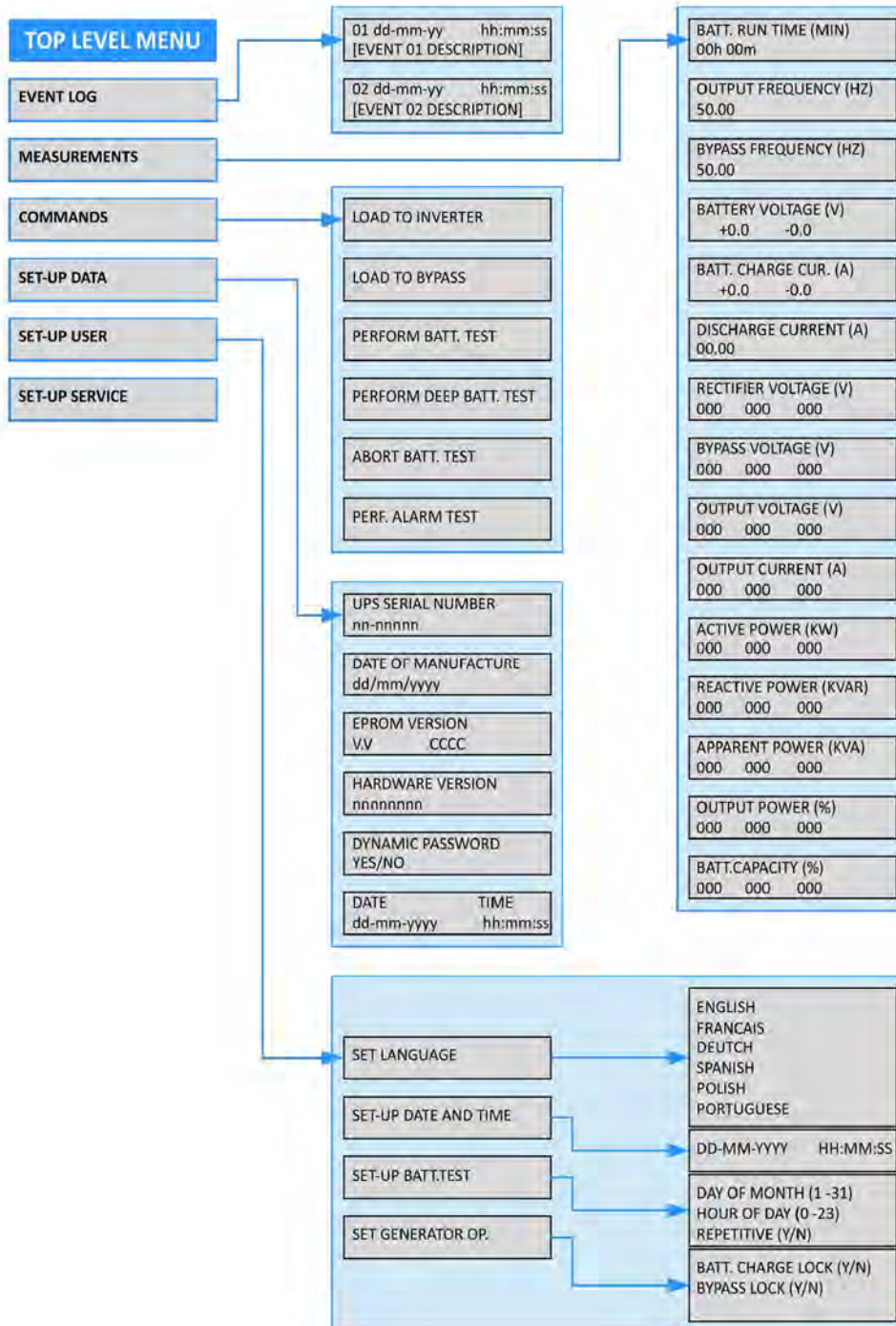

Figure 2.10 Module control panel menus

2.6 TFT Module control panel

The TFT control panel is designed around a microprocessor-based touch screen display and is a direct replacement for the standard LCD module control panel. It offers all the display and control functions of the LCD panel but made accessible through in a user-friendly touch screen interface. When the UPS is energised the display runs through an initialisation process for several seconds then displays the default mimic diagram screen shown below. The screen's back light turns off after three minutes of inactivity and turns on again automatically when the screen is touched.

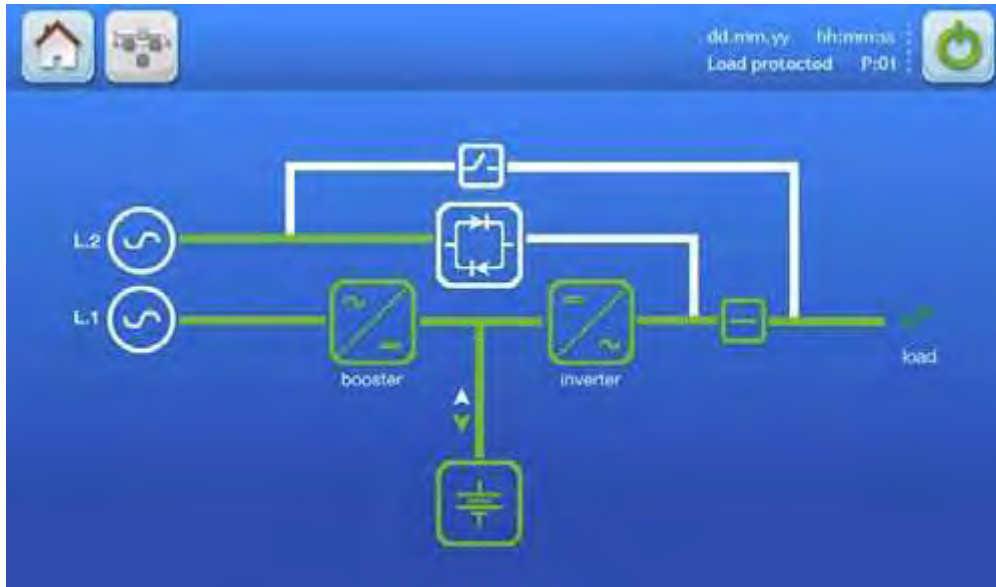

Figure 2.11 Mimic diagram screen (default)

2.6.1 Display header bar

A header bar containing various navigation buttons and status information is displayed at the top of every screen

A	Home	Accesses the HOME screen.				
B	Mimic diagram	Accesses the MIMIC diagram screen.				
C	Warning	The warning symbol is only visible in the presence of an alarm or monitored event. Touching this icon will silence the audible alarm and open the EVENTS screen.				
D	Date	Current date indication. Set in the USER menu and used to date-stamp the alarms/events log.				
E	Time	Current time indication. Set in the USER menu and used to time-stamp the alarms/events log.				
F	ON/OFF	Turns the UPS module ON/OFF. Requires a confirmation message to be accepted.				
G	UPS number	In a single module installation this would indicate S01. In a parallel system, each UPS module is allocated a sequential number. The number shown here is used to identify a particular module –e.g. P01 indicates the UPS number 01.				
H	Load Status	Indicates whether or not the load is protected, when the user is in the module navigation level.				

Figure 2.12 Display header bar

2.6.2 Mimic diagram screen

This is the default screen and shows the power flow through the UPS module and indicates its operating status. This screen can be accessed from any other screen by pressing the MIMIC icon (highlighted) in the display header bar.

The functional status of each block is identified by its line colour, as shown below in Figure 2.14, and the green connecting lines indicate the power flow in the system.

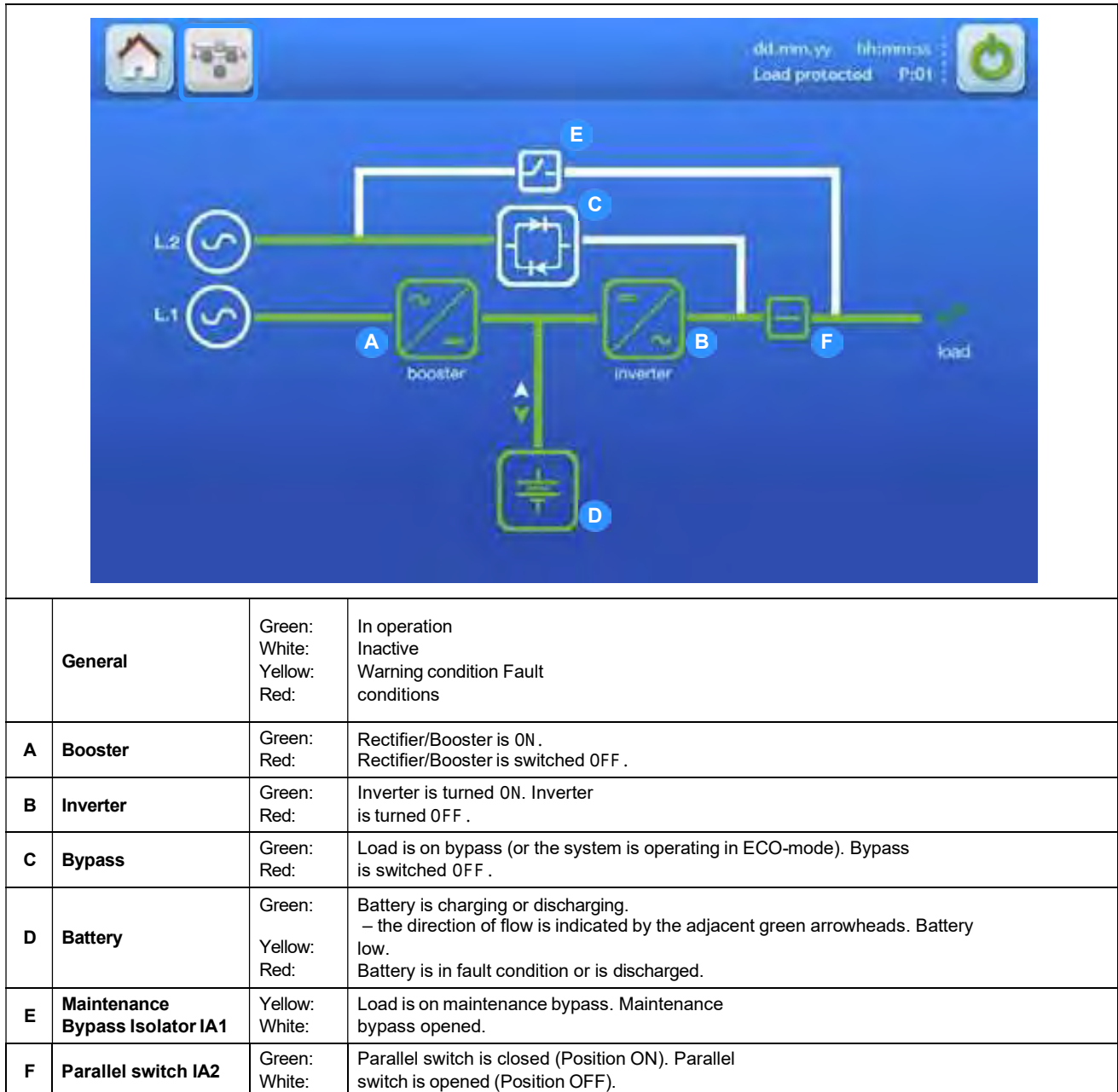

Figure 2.13 Mimic display screen

Three meters are included on the mimic display screen to indicate the rectifier, inverter, bypass and load operating parameters. The displayed battery parameters include the battery temperature and remaining autonomy time. The meter display source is selected by touching the associated interactive block on the mimic display.

2.6.3 Home screen

The home screen is accessed by pressing the HOME icon (highlighted) on the display header bar on any screen. It contains six touch-sensitive icons that provide access to various control, monitoring and set-up function screens.



Figure 2.14 Home display screen

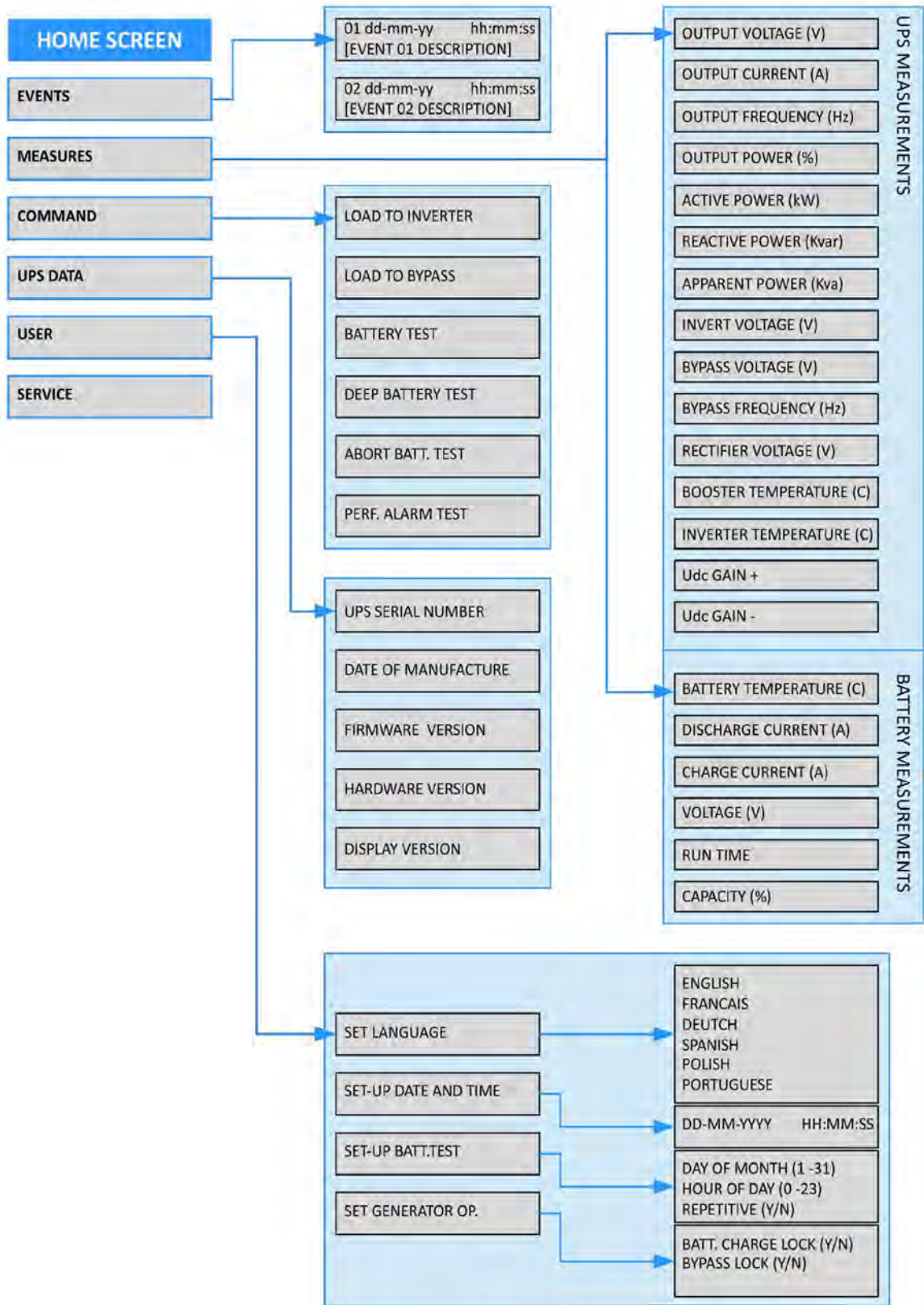

Figure 2.15 TFT Home Screen menus

2.7 Warranty

The Rehiko PW 6000 (400-500kVA) UPS is supplied with a limited warranty that the UPS and its component parts are free from defects in materials and workmanship for a period of one year from the date of original commissioning, or fifteen months from the date of original delivery, whichever is the sooner. This warranty is the only warranty given and no other warranty, express or implied, is provided.

This warranty is invalidated if the UPS is used without having first been commissioned by a fully trained and authorised person. This warranty does not apply to any losses or damages caused by misuse, abuse, negligence, neglect, unauthorised repair or modification, incorrect installation, inappropriate environment, accident, act of God or inappropriate application.

If the UPS fails to conform to the above within the warranty period then Rehiko will, at its sole option, repair or replace the UPS. All repaired or replaced parts will remain the property of Rehiko.

As a general policy, Rehiko does not recommend the use of any of its products in life support applications where failure or malfunction of the product can be reasonably expected to cause failure of the life support device or to significantly affect its safety or effectiveness. Rehiko does not recommend the use of any of its products in direct patient care. Rehiko will not knowingly sell its products for use in such applications unless it receives in writing assurances satisfactory to Rehiko that the risks of injury or damage have been minimized, the customer assumes all such risks and the liability of Rehiko is adequately protected under the circumstances.



CAUTION: *The UPS system may contain batteries which must be re-charged for a minimum of 24 hours every six months to prevent deep-discharging. Batteries that have been, for whatever reason, deeply-discharged are not covered by the warranty.*

2.8 Extended Warranty

The Standard Warranty may be enhanced by protecting the UPS with an Extended Warranty Agreement (maintenance contract). An Extended Warranty Agreement enhances the standard warranty by providing:

- Regular preventative maintenance inspections
- Guaranteed speed of response to operational problems
- 24 hour telephone support
- Fully comprehensive (excluding batteries) cover

2.9 Contacting service

Rehiko has a service department dedicated to providing routine maintenance and emergency service cover for your UPS. If you have any queries regarding your UPS please contact us.

UK

www.ups.rehiko.co.uk

ukservice.ups@rehiko.com

uktechnicalsupport.ups@rehiko.com

uksales.ups@rehiko.com

ukservicesales.ups@rehiko.com

Rehiko web site

Service department – booking service, fault reporting etc.

Technical queries

Hardware sales

Extended warranty agreements etc

IRELAND

www.ups.rehiko.ie

ieinfo.ups@rehiko.com

Rehiko web site

Service department, technical queries, hardware sales and extended warranty agreements

SINGAPORE

www.ups.rehiko.sg

salesups.sg@rehiko.com

serviceups.sg@rehiko.com

Rehiko web site

Hardware sales

Contract customer support, maintenance contracts renewals

3. Installation

3.1 Introduction

This chapter contains essential information concerning the unpacking, positioning, installing and cabling of the Rehiko PW 6000 (400-500kVA) UPS.



Key Point: If you are installing an external battery cabinet supplied by Rehiko you should refer to the manual that is provided with the cabinet for installation instructions.



WARNING: All cabling operations must be supervised by an authorised electrician or other suitably qualified person. All installation procedures must be carried out in strict accordance with the instructions contained in this manual. Rehiko will take no responsibility for any personal injury or material damage caused by the incorrect installation, cabling or operation of this product.



WARNING: Once the UPS equipment is installed it must be commissioned by an engineer approved by Rehiko before it is powered-up. Rehiko will take no responsibility for any personal injury or material damage caused by the application of electrical power to this equipment before it has been fully commissioned.

3.2 Taking receipt of the UPS

The UPS and accessories are delivered on a purpose designed pallet that is easy to move using a forklift or pallet jack.



CAUTION: Observe the following precautions when off-loading and moving the UPS:

- Always keep the packages in an upright position.
- Do not drop the equipment.
- Do not stack the pallets.

Depending on the method of shipping, the UPS is packed in a cardboard or wooden container designed to protect it from mechanical and environmental damage. Further protection is provided by wrapping the equipment with a plastic sheet.

Before you accept the shipment ensure that the received package(s) correspond to the description shown in the delivery documentation. Note that some ordered optional equipment packages might be shipped inside the UPS cabinet.

Carefully examine the packing container for signs of physical damage. The external 'Tip&Tel' ("FRAGILE" and "ARROW") indicators should be intact if the equipment has been transported in an upright position.

3.2.1 Reporting transportation damage



WARNING: If the Tip&Tell indicators indicate that the UPS has been tilted in transit DO NOT connect the UPS to the mains electricity supply.

If the 'Tip&Tel' indicators are ruptured or there are other signs of suspected transportation damage you must inform the carrier and Rehiko immediately.

Other claims for shipping damage must be filed immediately when found, and the carrier must be informed of ALL claims within seven days of receipt of the equipment. If the equipment is to be stored for longer than seven days before it is installed, you should unpack it and inspect it for signs of internal damage before you put it into storage. Note that some optional equipment packages might be shipped inside the UPS cabinet and these too should be checked for damage.

If the equipment is damaged you should store the packing materials for further investigation.

3.2.2 Local transportation

When you transport the UPS equipment after it has been off-loaded please observe the following precautions.



CAUTION: Local transportation:

- When moving the UPS cabinet using a forklift or pallet jack, insert the lifting equipment forks into the front and rear shipping brackets to lift the cabinet securely and prevent it from toppling over.
- Do not at any time tilt the cabinet by more than 10° from vertical.



WARNING: Potential dangers:

- If the equipment cabinet is tilted by more than 10° it could cause internal damage. If tilting occurs do not connect the UPS to the mains electrical supply.
- The cabinet weight can cause serious personal injury and/or structural damage to the surrounding area if dropped in transit. Always take extreme care when moving the equipment.

3.2.3 Storage

If you plan to store the UPS prior to its installation it should be kept (preferably in its shipping packaging) in a clean, dry environment with a temperature between -25°C to +70°C and RH <90%. If the storage period is likely to exceed seven days the packaging should be removed and the UPS inspected for shipping damage before it is placed into storage. If there is no apparent damage you should either refit the packaging or cover the UPS with a dust-cover to prevent the ingress of dust and dirt.

3.3 Unpacking

1. If the cabinet is shipped inside a wooden case remove the screws at the base and sides of the case then carefully remove the case from the equipment pallet.
2. Cut the wrappers and remove the packing container by pulling it upwards.
3. Remove the plastic sheeting covering the UPS.
4. Remove any anchor bolts securing the cabinet to the pallet then remove the UPS from the pallet.
5. Retain the packaging materials for possible future shipment of the UPS.
6. Examine the UPS for signs of damage and notify your supplier immediately if any damage is found.
7. Check that the details on the UPS nameplate corresponds to the purchased material mentioned in the delivery note. The rating specifications can be found on a nameplate attached to the inside of the UPS door.

3.4 Planning the installation (environmental and mechanical)

3.4.1 Environmental considerations

1. The route to the installation location must allow the equipment to be transported in an upright position.
2. The floor at the proposed installation site and en-route from the off-loading point must be able to safely support the weight of the UPS and battery equipment, plus fork lift or trolley jack during transit.
3. The minimum clearances required around the UPS for cooling air flow and service access is shown in Rehiko
4. A temperature of 20°C is necessary to achieve the optimum battery life span. The cooling air entering the UPS modules must not exceed +40°C.
5. The floor material should be non-flammable and strong enough to support the heavy load.
6. In summary, the UPS should be located where:
 - a. Humidity is < 95% and temperature is 0~20°C. Ideally 20°C to for optimal battery life.
 - b. Fire protection standards are respected.
 - c. Cabling can be performed easily.
 - d. Adequate cooling air flow is available.
 - e. The air conditioning system can provide a sufficient amount of air cooling to keep the room at, or below, the maximum desired temperature.

- f. No dust or corrosive/explosive gases are present.
- g. The location is vibration free.

3.4.2 UPS Cabinet installation

Mechanical

As the cabinet can be install without side or rear access, you should carry out any necessary pre-installation of the power and control cables to ensure that the cables are fully accessible once the UPS is moved to its final position. The standard module is designed for bottom cable entry only, but top cable entry is possible with the addition of the Top Cable Entry (TCE) extension cabinet (see below). Note that when a TCE cabinet is installed, cable entry can be from top, bottom or a combination of the two.



IMPORTANT NOTE:

Rear access is required to change the module's input supply configuration between single-feed and dual-feed. If the module is to be located where rear access will be restricted you must ensure you change the input supply configuration (if required) before the cabinet is moved to its final position.

Clearances

All the control switches necessary to operate the equipment are accessible from the front of the cabinet and all cables enter the cabinet via the bottom-front or top (with an additional extension cabinet), therefore no side or rear cabinet access is needed.

The UPS is force-cooled by conditioned air entering the grills in the cabinet doors and extracted by fans mounted on the cabinet roof. A minimum of 400 mm is required above the cabinet to allow adequate cooling air flow.

Although the clearance diagram shows a minimum clearance of 1000 mm at the front of the cabinet, we recommend that this is increased where possible, to allow safe passage in front of the UPS cabinet with the doors open.

It is necessary to open the doors to 115° to gain full service access to some components, so if the cabinet is located adjacent to a partition or wall that extends beyond the front of the cabinet a clearance of up to 250 mm should be provided between the side of the cabinet and the wall to allow the doors to open adequately, as shown in Figure 3.1 (C2). Note that no space required between cabinets in a parallel system.

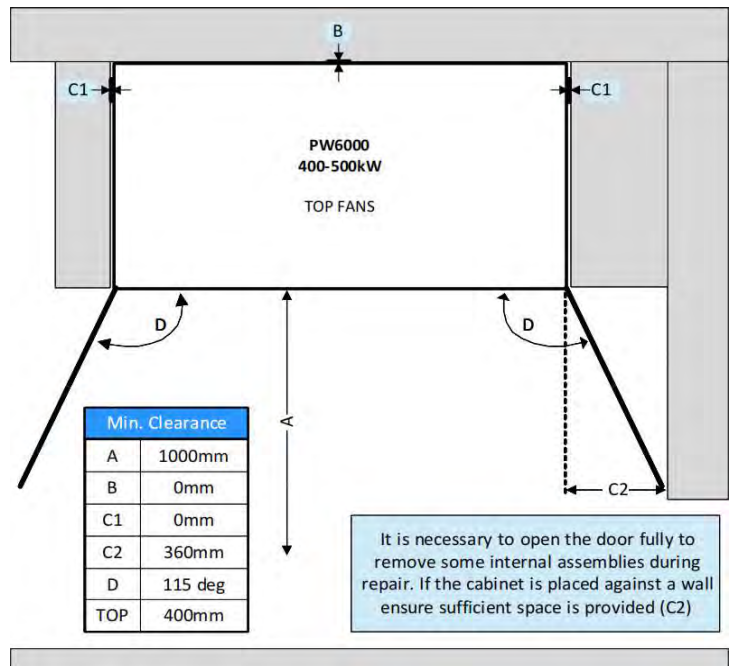

Figure 3.1 UPS Cabinet clearance recommendations

3.4.3 Top Cable Entry (TCE) extension cabinet installation

As mentioned above, a standard PW 6000 (400-500kVA) UPS cabinet is designed for bottom cable entry only. However, an optional Top Cable Entry (TCE) extension cabinet can be attached to the left of the standard UPS cabinet to facilitate top cable entry (or a combination of both top and bottom cable entry).

The optional TCE installation kit comprises:

- A purpose designed TCE cabinet enclosure containing all the necessary power connection busbars.
- A hardware accessory pack that is used to attach the TCE enclosure to the UPS cabinet.

- A set of ready-made cables for connecting the TCE enclosure to the UPS power terminals.

The enclosure is delivered on a specifically designed pallet that can be moved easily using a forklift or a pallet jack. The accessories pack is shipped inside the enclosure and the cable set is delivered in a separate package.

Installation notes

The TCE enclosure is attached to the left side of the UPS cabinet using the hardware accessories pack that is shipped inside the enclosure. These notes outline the effects of installing the TCE enclosure on the installation procedures given earlier in this chapter.

1. When installing the TCE enclosure, all the information and recommendations contained in paragraph 3.4 are still valid except for the unit weight and dimensions. The TCE enclosure weighs 115 kg and will add a further 500 mm to the width of the UPS cabinets (see Figure 2.1).
2. The recommended clearances shown in Figure 3.1 remain valid.
3. All external cable and fuse sizing data provided in paragraph 3.5.4 remain valid

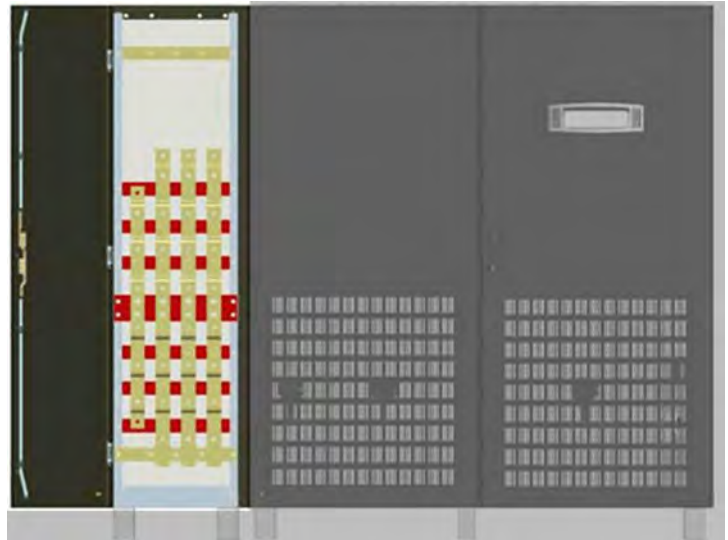

Figure 3.2 Optional top cable entry (TCE) enclosure in-situ



WARNING: When handling the TCE enclosure, or its packaging, please observe the precautions mentioned in paragraph 3.2.2.

TCE Enclosure mechanical installation

You must ensure that the UPS cabinet is correctly positioned at its intended final location before you install the enclosure.

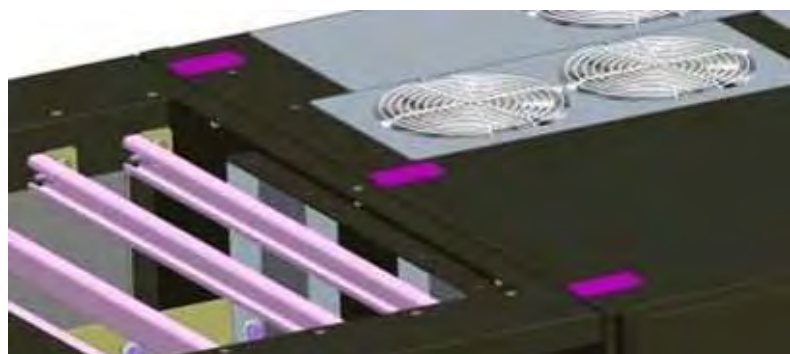

Figure 3.3 U-brackets Figure 3.4 Cabinet tie bars

1. Unpack the TCE enclosure and remove any internal packing materials, taking care not to discard the hardware accessory pack which contains all the hardware and screws required to install the TCE enclosure.
2. Attach the two U shaped brackets to the left base of the UPS cabinet using 2x M5 screws to secure each bracket, as shown in Figure 3.3 – affix the screws through the base of the UPS into the brackets.
3. Position the TCE enclosure adjacent to the UPS cabinet, ensuring that the front of the cabinets are properly aligned.

4. Attach the base of the TCE enclosure to the two U shaped brackets using 2x M5 screws to secure each bracket – affix the screws through the base of the enclosure into the brackets.
5. Using 6x M5 screws, secure the tops of the cabinets together by fitting three tie bars, as shown in Figure 3.4.

3.4.4 Battery installation

The battery installation is bespoke. We recommend that where possible the battery is contained in a purpose-designed cabinet installed immediately adjacent to the UPS cabinet. It can be positioned on either side of the UPS cabinet but ideally it should be installed to the right of the UPS to minimise the length of the interconnecting DC cables.

If the batteries are to be mounted on external battery racks, rather than in a cabinet, the battery cables must be sized to take into account the DC voltage drop between the battery installation and UPS. Contact Rehiko for installation advice and support if necessary.

3.5 Planning the installation (cabling considerations)

3.5.1 General requirements

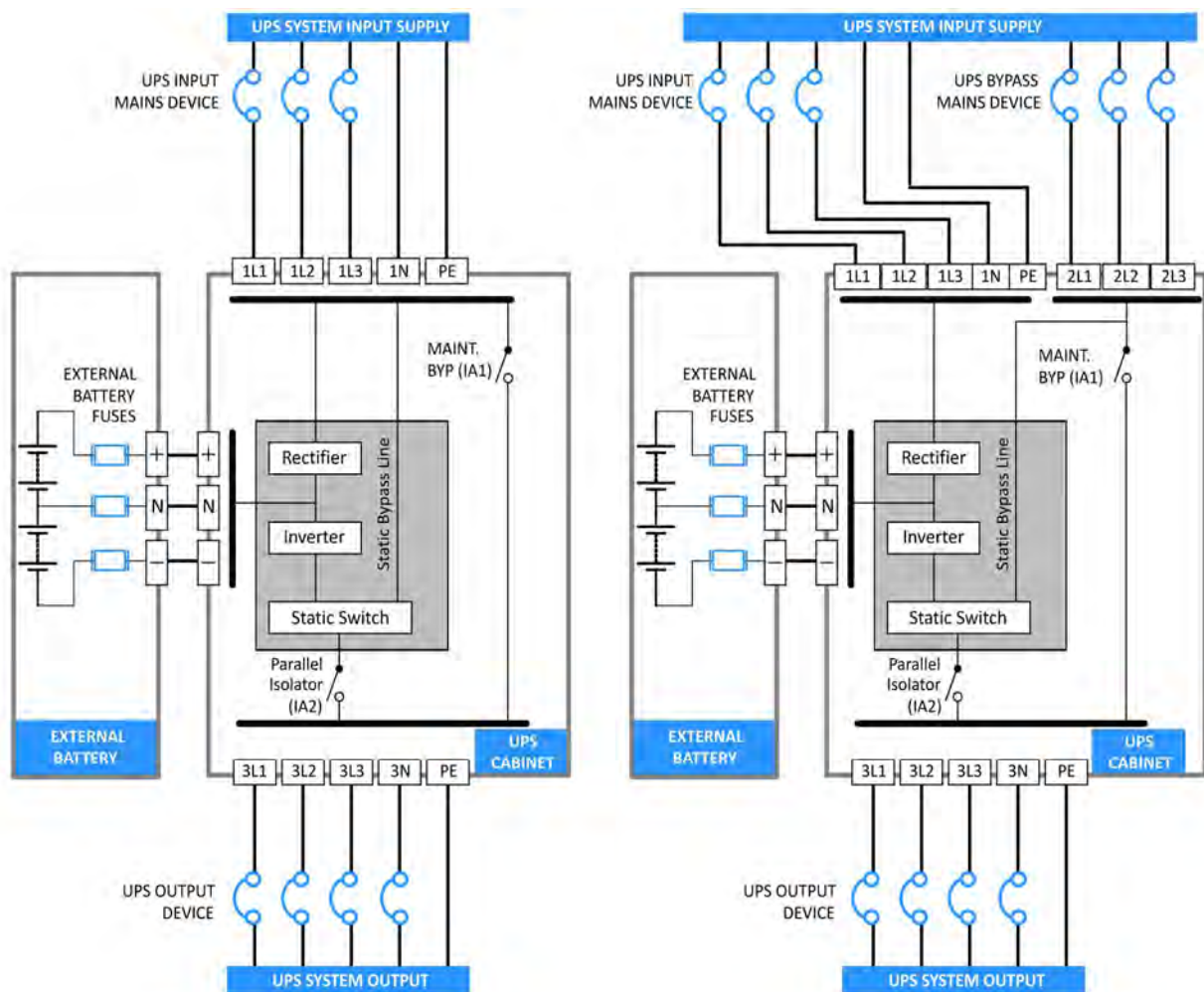

Figure 3.5 Power connections for single feed (left) and dual feed installations

The UPS cabinet can be designed for a single feed input, where the input mains and bypass mains terminals are linked internally, or for a dual feed input where the links are removed and the bypass mains is connected to a dedicated mains supply. The two configurations are shown in Figure 3.5. It is the customer's responsibility to design and install the UPS supply and distribution circuits and provide the external fuses, isolators and cables necessary to connect the UPS input supply, output

supply and battery. The information contained in this section should assist in the planning and preparation of the UPS power cabling.

As shown in Figure 3.5, the UPS input mains and bypass mains should be connected to the UPS via a circuit breaker or suitably rated fused input device to provide both overload protection for the UPS and a means of isolating the UPS from the mains supply.

Similarly, the UPS output should be connected to the load equipment via a suitably rated UPS output device.

The battery installation requires fuses fitted in the battery positive, negative, and mid-point (neutral) feeds, as shown in Figure 3.5. Rehlko can supply a range of matching battery cabinets containing the necessary fuses and switchgear on request.

3.5.2 Parallel cabinet cabling recommendations

All the UPS cabinets in a parallel system must be connected to the same mains power source and the cables from the UPS supply panel to each cabinet should be of equal length. Similarly, the output cables connected between the UPS cabinets and the UPS system output distribution panel should be of equal length, as shown in Figure 3.6. This helps to balance the load sharing between the cabinets.

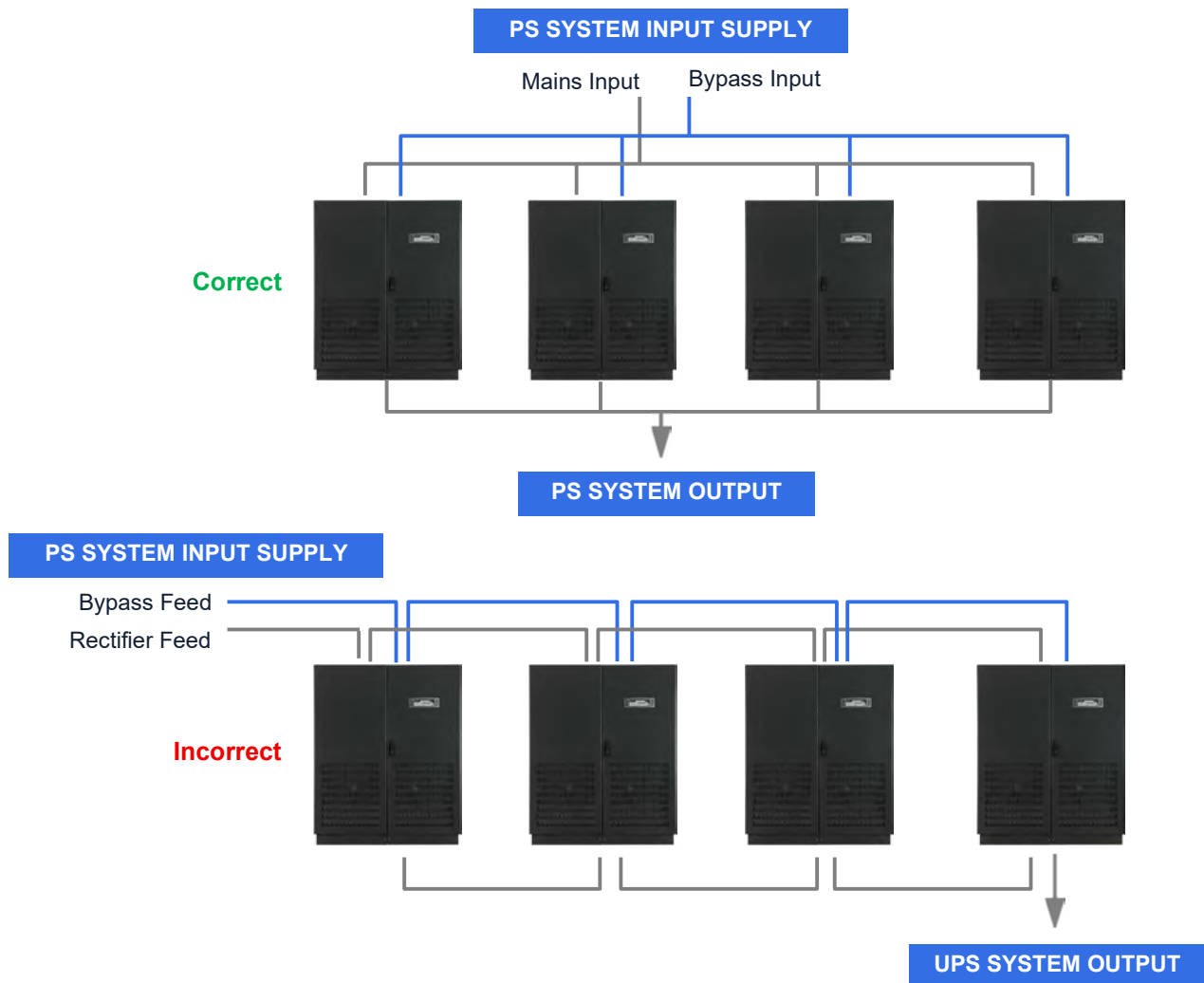

Figure 3.6 Parallel cabinet cabling recommendations

Input neutral grounding

The input neutral must be permanently connected to enable the rectifier to operate correctly and allow the UPS to function properly when it is operating on battery power.



Key Point: As the input neutral must be unswitched and connected to the UPS at all times. DO NOT use, a 4-pole input switch or isolator at the LV supply board on a TN-S system.

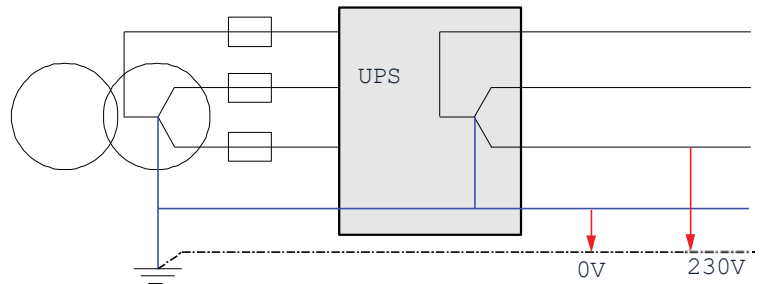

Figure 3.4 Permanent, grounded input neutral

Figure 3.4 Permanent, grounded input neutral

External Backfeed protection

A UPS shall prevent hazardous voltage or hazardous energy from being present on the UPS input AC distribution after interruption of the input AC power. This is achieved by mandatory backfeed protection. Unless optional internal protection is included in UPS frame, such protection shall be provided by others and be installed as part of building installation. The backfeed protection shall be implemented in the form of an air gap, separating the upstream circuit from UPS when AC input fails. This is typically achieved through a contactor installed over the common AC input line or over each separate AC input line. Preferred location is just after the overcurrent protective devices serving each UPS input line. Such contactors shall have the coil supplied by the AC upstream circuit, to be engaged when AC upstream voltage is ON or dis-engaged when AC upstream voltage is OFF.

Specifications:

The device shall be three-poles, creating an air gap of at least 3 mm.

The thermal current shall meet the external overcurrent protection's rating described in the coming sections.

Electrical contractor is required to attach following "Voltage backfeed warning label" as close as possible to the external isolator:

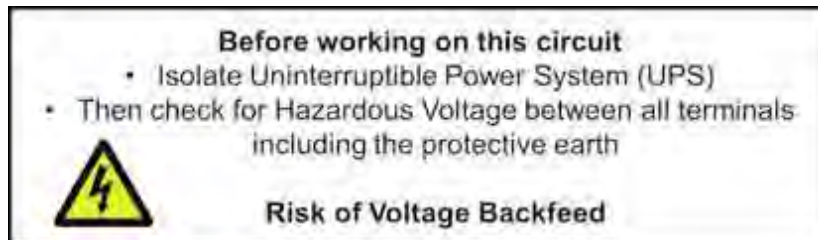

3.5.3 External maintenance bypass switch

An external maintenance bypass is a required part of a multi-cabinet system but is optional in the case of a single cabinet installation.

The external bypass is bespoke to the installation but generally comprises three switches rated to carry the full system load and connected in a similar fashion to that shown in Figure 3.8.

The switches may be installed in a dedicated external Maintenance Bypass switch cabinet or included in an existing (or dedicated) switchgear panel. Rehiko can supply a range of external maintenance bypass solutions to suit all of its UPS systems.

Note: The UPS start-up procedure recommends that you turn on the load while the UPS is operating on maintenance bypass if the load produces a large inrush current.

Single UPS cabinet installation

An external maintenance bypass facility is not an essential part of a single cabinet installation as the internal maintenance bypass switch (IA1) is fully load rated for the cabinet output.

However, in a single module installation it is not possible to fully power-down the UPS (for test/repair) when the internal maintenance bypass switch (IA1) is closed, because the bypass mains supply is required to power the maintenance bypass circuit.

This situation can be overcome by adding an external maintenance bypass (MBP) facility, similar to that shown in Figure 3.8, which can supply the load through the external BYPASS switch while allowing the UPS cabinet input and output power terminals to be totally isolated by opening the external MBP INPUT and OUTPUT switches.

Parallel system installation

When two, or more, UPS cabinets are connected as a parallel system an external maintenance bypass facility is as essential part of the UPS installation, and the individual maintenance bypass switches (IA1) are not installed in the UPS cabinets.

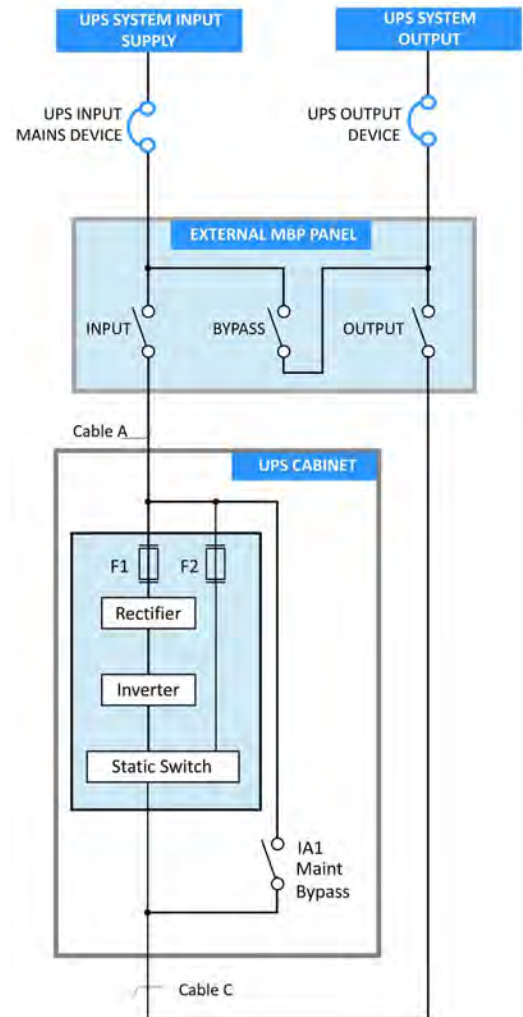

Figure 3.8 External Maintenance Bypass

3.5.4 Cable sizing

Figure 3.9 identifies (in red) the power cables, fuses and other protective devices that must be provided by the customer. The table shows the maximum UPS input and output current for each set of cables together with the cable termination details. This is provided to assist the customer in selecting appropriately rated power cables and external switchgear.



Key Point: All external fuses, isolators and power cables must be rated and installed in accordance with the prescribed IEC standards or local regulation – e.g. BS7671.

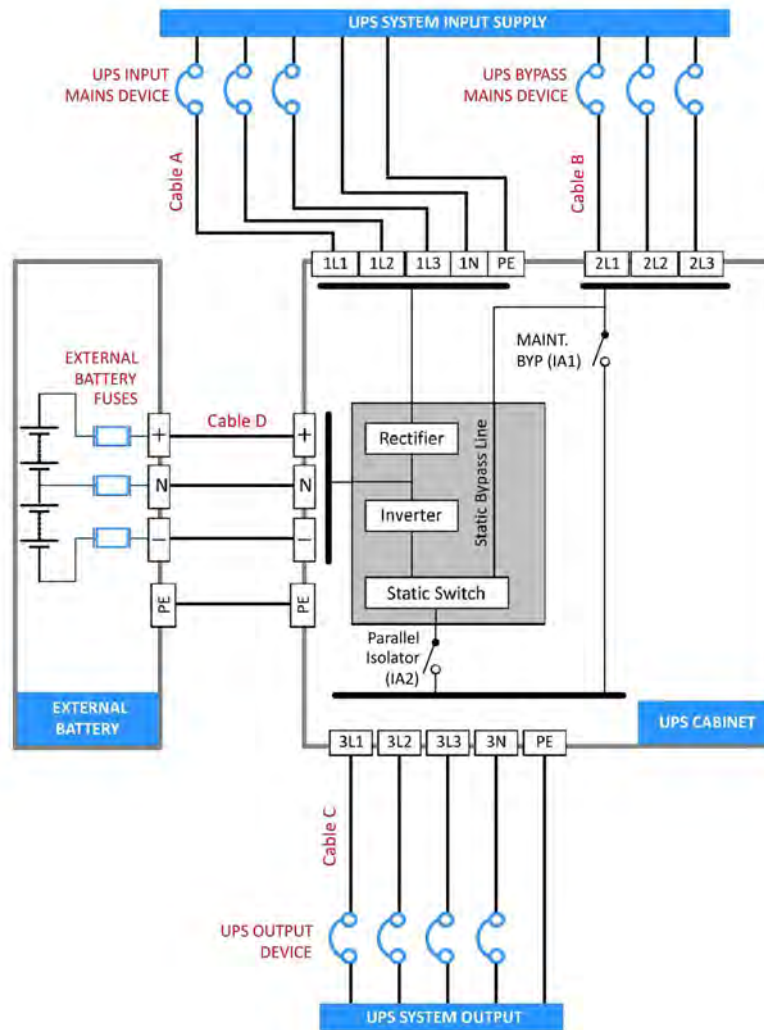

MODEL	INPUT MAINS (A)		BYPASS MAINS (B)		OUTPUT (C)		BATTERY (D)
	Max Current	Terminal	Max Current	Terminal	Max Current	Terminal	Terminal
400 kW	679 A	3x (5 x M12)	578A	3x (4 x M12)	578 A	3x (5 x M12)	3x (4 x M12)
500 kW	848 A	3x (5 x M12)	722 A	3x (4 x M12)	722 A	3x (5 x M12)	3x (4 x M12)

Current ratings shown for 400V, 100% Linear load and maximum battery charging.

All terminals should be tightened to a torque of 75 Nm

Figure 3.9 Cable sizing

3.6 Electrical installation (cabling procedures)

This section contains two procedures. The first procedure (paragraph 3.6.1) applies to a standard UPS module using bottom cable entry, and the second (paragraph 3.6.2) describes the top cable entry procedure to be used in conjunction with the optional Top Cable Entry (TCE) cabinet.

Safety notes

Please ensure you read and understand the following safety notes before you begin the UPS electrical installation.

1. Do not connect the UPS until its mechanical installation is completed.
2. All the operations detailed in this section must be supervised by an authorised electrician.
3. After the electrical installation is completed, the initial UPS start-up must be performed by qualified commissioning engineer authorised by Rehiko.



WARNING: Do not apply electrical power to the UPS before it has been commissioned and handed over.

4. Do not work on the UPS if there is water or moisture present.
5. Before you begin the electrical installation of the UPS ensure that the UPS input and output (load) supplies are isolated and locked-out at their respective distribution boards. Warning notices should be posted to prevent any inadvertent operation of the UPS supply isolators.
6. Check that the fuses and cables provided by the customer are suitably rated in accordance with the prescribed IEC standards or local regulations (for example BS7671).
7. For your personal protection, ensure the following conditions are met before you work on the equipment:
 - a. No mains voltage is present at the UPS mains/bypass distribution board terminals.
 - b. All loads are shut down and disconnected at the load distribution board.
 - c. The UPS is fully shut down and voltage-free.
 - d. The UPS Maintenance Bypass Isolator IA1 is open (OFF) – located in an external switch cabinet in a parallel module system.
 - e. The UPS Isolators IA2, IA3 and IA4 are open (OFF).

3.6.1 Bottom entry cabling procedure

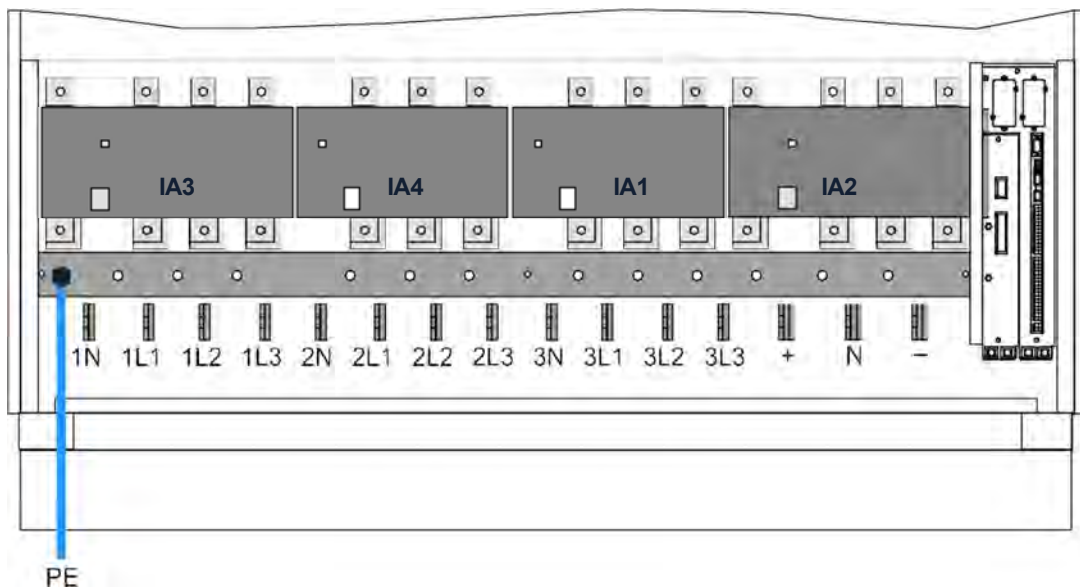

Figure 3.10 UPS cabinet power terminals

In a bottom cable entry installation the UPS power cables are connected to busbars located just below the power isolators near the bottom of the cabinet. Figure 3.10 identifies the power connections.

Note: although Figure 3.10 shows all four UPS power isolators, the Maintenance Bypass Switch (IA1) is not fitted to a parallel module UPS cabinet because an external maintenance bypass facility will be installed.

Due to the required high current rating of the UPS power cables, the supply connections are usually made using several cables connected in parallel rather than using a single large cable. This makes the cables easier to handle and allows smaller radius bends to be applied when routing the cables to the UPS terminals.

Each power connection busbar therefore has three holes through which the paralleled power cables can be attached and secured using M12 bolts. For example, Figure 3.11 illustrates the battery positive (red), neutral (blue) and negative (white) connections with each one made using three parallel-connected cables. For reasons of clarity the busbar connections are referred to as the 'rear', 'middle' and 'front' holes in the following procedures.

Bottom cable entry requires a cable support kit to be installed below the power terminals to provide a means of holding the cables securely in place. The kit contains several cabinet-wide support bars that are fitted behind of each row of cables and must be installed progressively as the power cables are connected, as described below.

A cable support kit, containing all the necessary fittings and securing hardware, is shipped separate to the UPS cabinet.

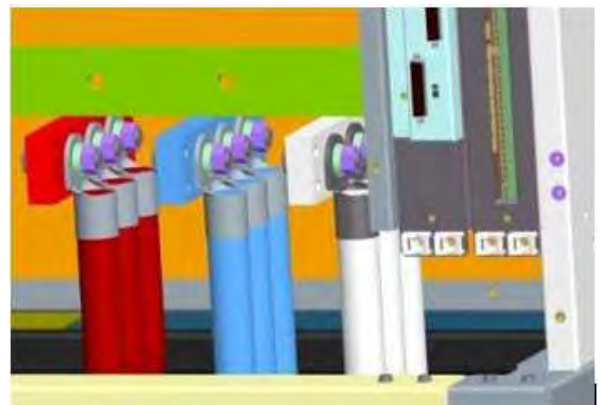

Figure 3.11 Power connections

1. Ensure the UPS module is configured appropriately for single/dual input supply operation.
2. After the UPS cabinet has been moved to its final position, remove and discard the two transport bars – shown in Figure 3.12.
3. Temporarily remove the front bottom bar. (It will be refitted later in the procedure.)

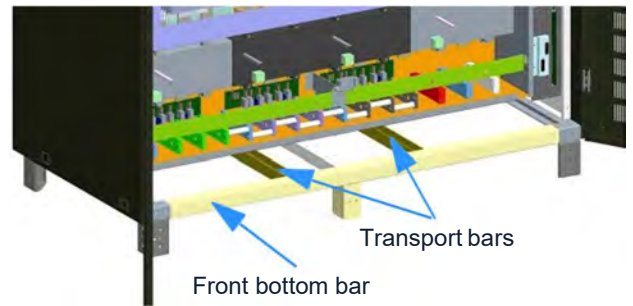

Figure 3.12

4. Install the four profiles (A), (B), (C), (D) as illustrated in Figure 3.13. Each profile should be secured using two M5 screws tightened to 6.0 Nm.

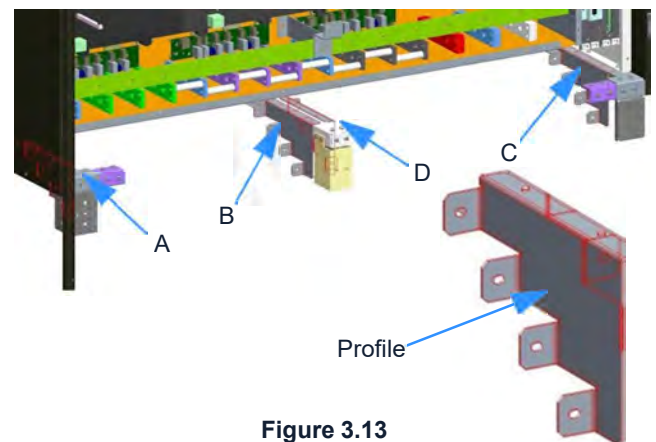

Figure 3.13

5. Fit two cable support bars (E), (F) between the rear-most lugs on profiles (A), (B), (C) as shown in Figure 3.14. Secure each bar using two M5 nuts and bolts tightened to 6.0 Nm.
6. Connect the appropriate power cables to the rear holes in the busbar terminals (1N, 1L1, 1L2, 1L3), (2N, 2L1, 2L2, 2L3 in dual input system), (3N, 3L1, 3L2, 3L3), (Batt +, Batt N, Batt -).

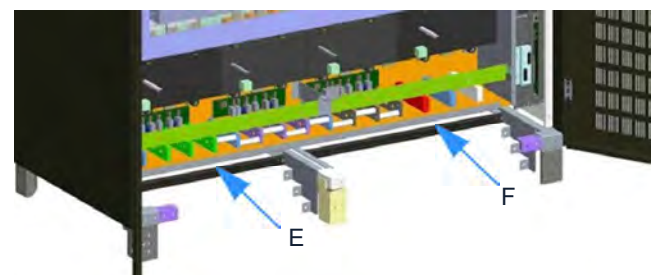

Figure 3.14

7. Once the rear cables are connected, secure them to the rear cable securing bars just fitted.
8. Fit two cable securing bars (G), (H) between the next set of lugs on profiles (A), (B), (C) as shown in Figure 3.15. Secure each bar using two M5 nuts and bolts tightened to 6.0 Nm.
9. Connect the appropriate power cables to the middle holes in the busbar terminals (1N, 1L1, 1L2, 1L3), (2N, 2L1, 2L2, 2L3 in dual input system), (3N, 3L1, 3L2, 3L3), (Batt +, Batt N, Batt -).

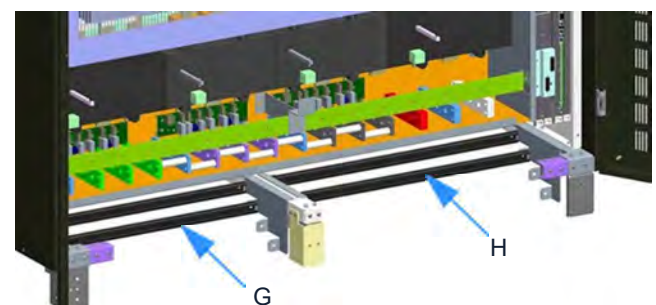

Figure 3.15

Note: For reasons of clarity the cables connected to the rear holes are not shown in Figure 3.15.

10. Once the middle cables are connected, secure them to the middle cable securing bars just fitted.

11. Fit two cable securing bars (I), (J) between the next set of lugs on profiles (A), (B), (C) as shown in Figure 3.16. Secure each bar using two M5 nuts and bolts tightened to 6.0 Nm.
12. Connect the appropriate power cables to the front holes in the busbar terminals (1N, 1L1, 1L2, 1L3), (2N, 2L1, 2L2, 2L3 in dual input system), (3N, 3L1, 3L2, 3L3), (Batt +, Batt N, Batt -).
13. *Note: For reasons of clarity the cables connected to the rear and middle holes are not shown in Figure 3.16.*
14. Once the front cables are connected, secure them to the front cable securing bars just fitted

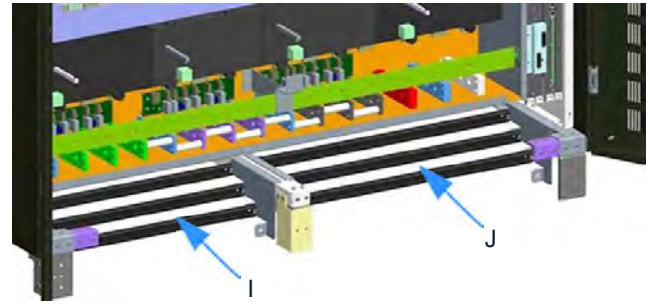

Figure 3.16

15. Fit the final two cable securing bars (K), (L) between the front set of lugs on profiles (A), (B), (C) as shown in Figure 3.17. Secure each bar using two M5 nuts and bolts tightened to 6.0 Nm.
16. Connect the Input, Bypass and output Earth cables to the earth busbar (M).
17. *Note: For reasons of clarity the cables connected to the power busbars are not shown in Figure 3.15.*
18. Once the earth cables are connected, secure them to the cable securing bars just fitted.
19. Finally, refit the front bottom bar that was removed at the beginning of this procedure.
20. This completes the module bottom entry power cabling.

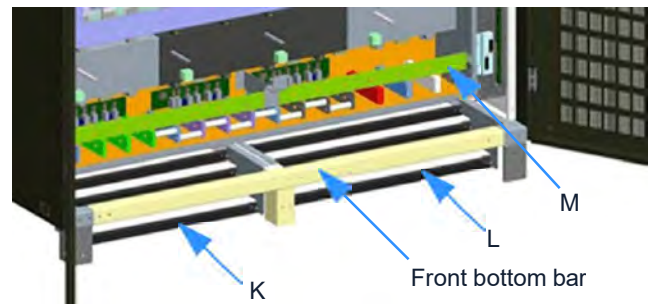

Figure 3.17



WARNING: The UPS must be commissioned by a Rehiko approved engineer. **DO NOT APPLY POWER TO THE UPS BEFORE IT HAS BEEN FULLY COMMISSIONED.**

3.6.2 Top entry cabling procedure

Cable connection identification

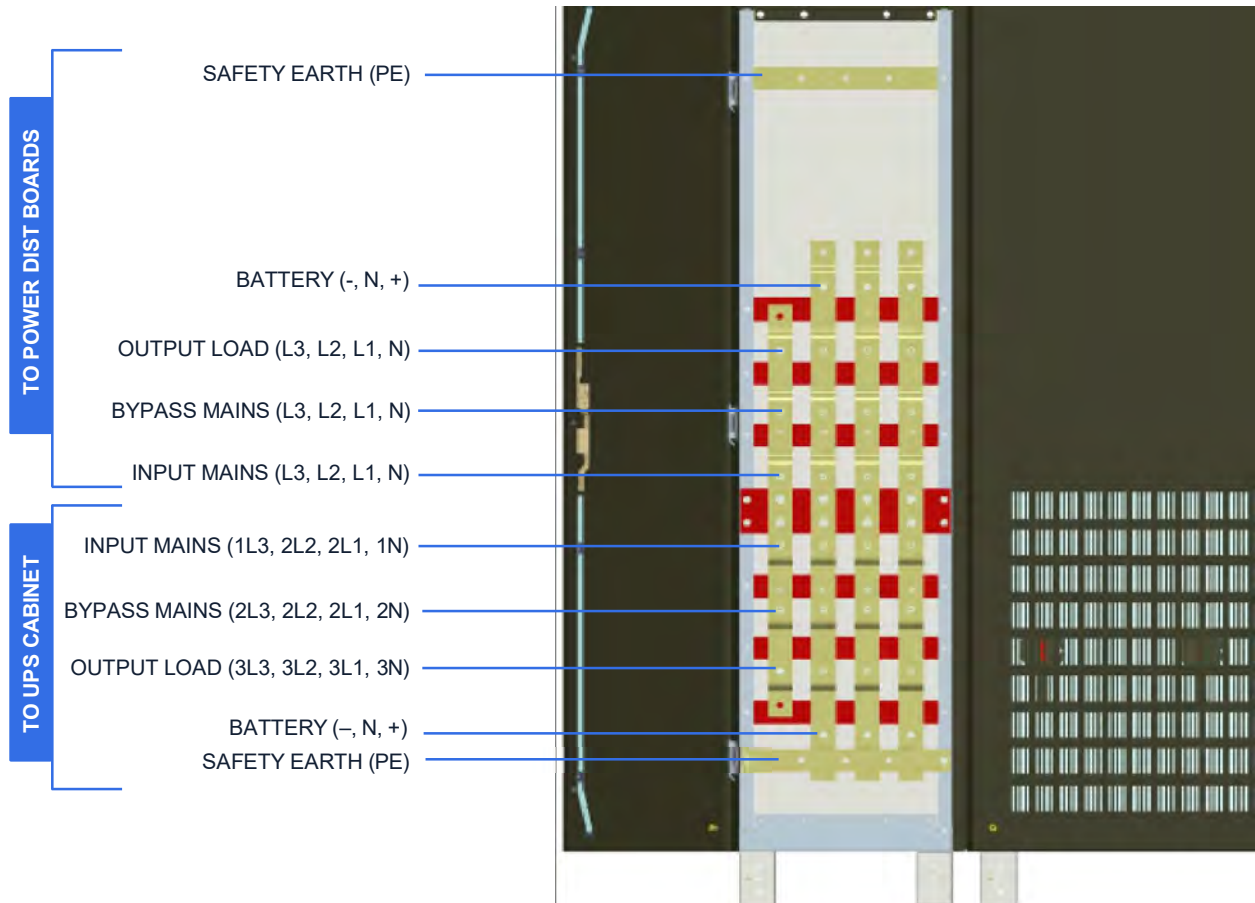

Figure 3.18 Power cables connection identification

If the UPS installation requires top cable entry a purpose designed extension cabinet must be attached to the left of the UPS cabinet as detailed in paragraph 3.4.3. The TCE cabinet contains vertically-mounted busbars for each of the UPS input, output and battery power connections, as shown in Figure 3.18.

The TCE cabinet is connected in two stages: the UPS cabinet is first connected to the bottom of the TCE cabinet busbars using link cables that are supplied with the cabinet, then the external power cables are connected to the top of TCE busbars.

Note that it is possible to have a combination of top and bottom entry cable entry: for example an installation might require top entry for the input and output AC power cables, but employ bottom cable entry to connect to an adjacent battery cabinet. Where this is the case, the cable support kit described in paragraph 3.6.1 must be installed to support those cables entering directly through the bottom of the UPS cabinet.

For reasons described earlier, the UPS power connections are usually made using several cables connected in parallel rather than using a single large cable. The connections at each end of the busbars therefore have two, offset M12 holes through which the cable can be attached. Figure 3.19 shows the recommended method of connecting three parallel cables.

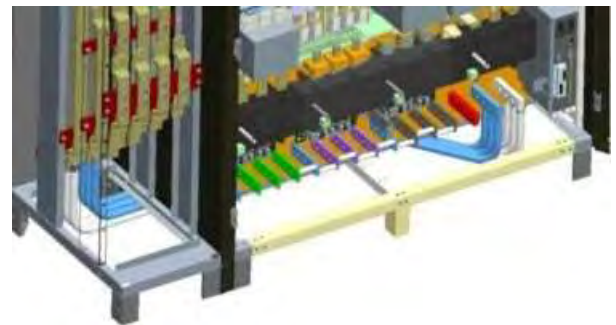
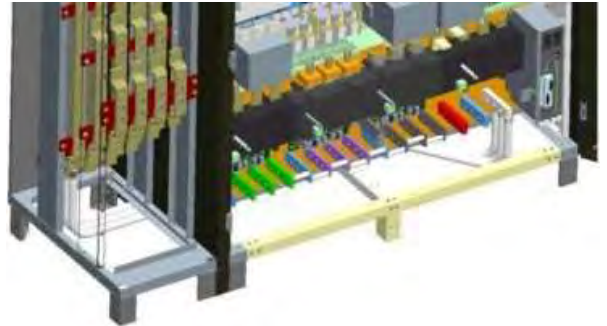

Figure 3.19

Interconnection cabling procedure

Note: This procedure is made easier if you temporarily remove the TCE and UPS left door for access.

1. Connect the battery negative cables to the TCE enclosure battery negative busbar (see also Figure 3.19).
2. Lay the battery negative cables on the ground towards the back of the UPS cabinet, as shown.
3. Connect the battery negative cables to the UPS cabinet's battery negative busbar (see also Figure 3.10).
4. Connect the battery neutral cables to the TCE enclosure battery neutral busbar.
5. Place the battery neutral cables on top of the battery negative cables installed above, then connect them to the UPS cabinet's battery neutral busbar.



6. Connect the battery positive cables to the TCE enclosure battery positive busbar.
7. Place the battery positive cables on top of the battery neutral cables installed above, then connect them to the UPS cabinet's battery positive busbar.

The completed battery cabling should appear similar to that shown in the accompanying diagram.

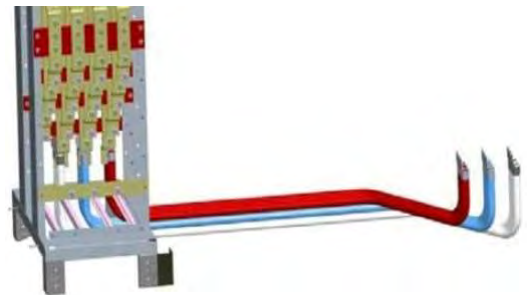

8. Repeat the above procedure for the UPS output cables. Begin by connecting the 3L3 cables between the TCE enclosure and the UPS cabinet. Placing the cables on the ground immediately in front of the battery cables.

9. Next connect the 3L2, 3L1 and 3N cables in turn placing each set of cables on the ones below.

The completed output cabling should appear similar to that shown in the diagram alongside.

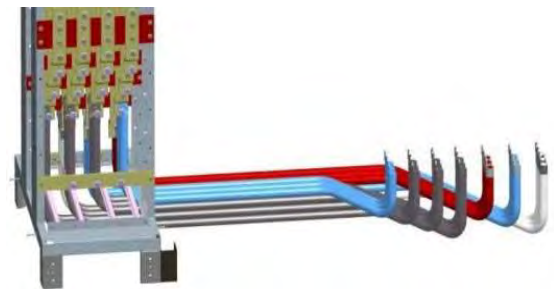

10. Repeat the above procedure for the bypass input cables (dual feed system only). Begin by connecting the 2L3 cables between the TCE enclosure and the UPS cabinet. Placing the cables on the ground immediately in front of the UPS output cables.

11. Next connect the 2L2, 2L1 and 2N cables in turn placing each set of cables on the ones below.

The completed output cabling should appear similar to that shown in the diagram alongside.

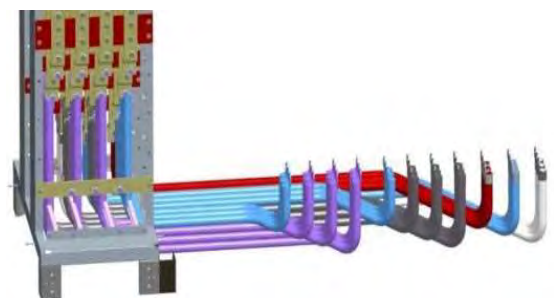

12. Repeat the above procedure for the input mains (rectifier) cables.

Begin by connecting the 1L3 cables between the TCE enclosure and the UPS cabinet. Placing the cables on the ground immediately in front of the bypass input cables.

13. Next connect the 1L2, 1L1 and 1N cables in turn placing each set of cables on the ones below.

The completed output cabling should appear similar to that shown in the accompanying diagram.

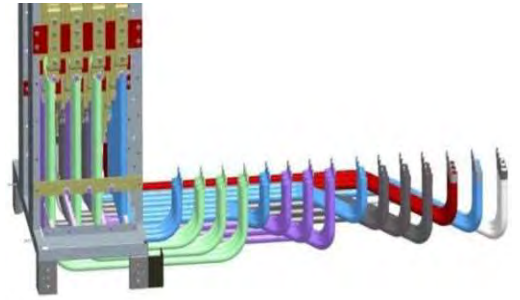

14. Finally, repeat the above procedure for the protective earth cables.

Begin by connecting the PE3 cable between the TCE enclosure and the UPS cabinet. Placing the cables on the ground immediately in front of the input mains cables.

15. Next connect the PE2 and PE1 cables in turn placing each set of cables on the ones below.

16. This completes the interconnecting cabling which should now appear similar to that shown in the accompanying diagram.

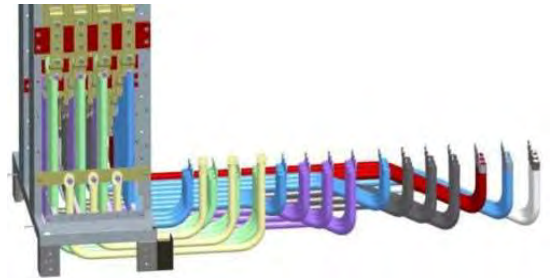

Note: If you removed the UPS cabinet left door for access you can now refit it. Remember to connect the earth bonding wire to the door once it is fitted.

External cabling procedure

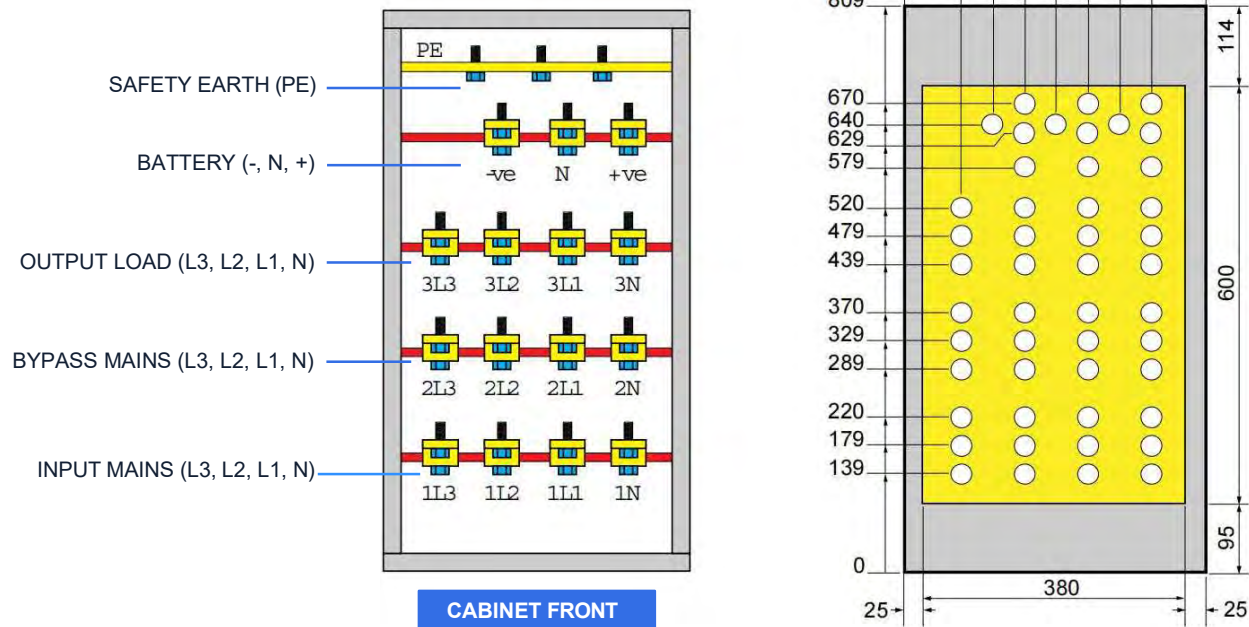

Figure 3.20 TCE Cabinet top view

Figure 3.20 shows the location of the various power busbars when viewed from the top of the TCE cabinet. The right-hand drawing illustrates the position of the busbar terminals below the aluminium top plate, which can be removed for drilling and fitting suitable cable glands. Note that this illustration is provided for guidance only and does not specify the exact positioning of required gland holes.



WARNING: Before you begin this procedure you must ensure that the UPS external power supplies are isolated at source. Observe the safety notes on page 29.

Figure 3.20 shows that when looking from the top of the TCE cabinet the terminal busbars are arranged in sequence as Earth (PE), Battery, UPS Output, Bypass Mains and Input Mains. When you connect the power cables it is normally easiest to work forward from the back connections, as follows:

1. Connect the protective earth (PE) cables from the input distribution panel, output distribution panel and battery cabinet to the earth busbar at the top rear of the TCE cabinet.
2. Ensure that the external battery fuses are removed, then connect the battery cabinet to the battery negative, neutral, and positive busbars in the TCE cabinet.
3. Connect the UPS output cables (3L1, 3L2, 3L3, 3N) between the TCE and the load distribution panel.
4. If the UPS is configured for a dual input supply, connect the UPS bypass cables (2L1, 2L2, 2L3, 2N) between the TCE and the bypass mains distribution panel.
5. Connect the UPS input mains cables (1L1, 1L2, 1L3, 1N) between the TCE and the input mains distribution panel.
6. This completes the UPS power cabling.

Note: If you removed the TCE cabinet door for access you can now refit it. Remember to connect the earth bonding wire to the door once it is fitted.



WARNING: The UPS must be commissioned by a Rehiko approved engineer. **DO NOT APPLY POWER TO THE UPS BEFORE IT HAS BEEN FULLY COMMISSIONED.**

3.6.3 Connecting the battery

IMPORTANT NOTE

High voltage battery strings can be extremely dangerous and **should not** be installed by the customer's installation team. The batteries must be installed and connected to the UPS by a Rehiko service engineer.

It is the customer's responsibility to provide appropriate containment for the DC power cables between the UPS cabinet and battery cabinet where necessary – e.g. cable trays or trunking. Contact Rehiko for further installation advice if required.

3.7 Single/Dual feed conversion



Key Point: Back access must be fully available to change the UPS input supply configuration between single-feed and dual-feed. If the cabinet is to be located where rear access will be restricted, you must ensure the input supply configuration is correctly set before it is moved to its final position.

Unless otherwise specified, the UPS module is usually configured for a single feed input connections when it leaves the manufacturers. If required, you can convert the module to a dual feed input configuration using the following procedure:



CAUTION: UPS back panel weighs approximately 20kg. Take care when handling.

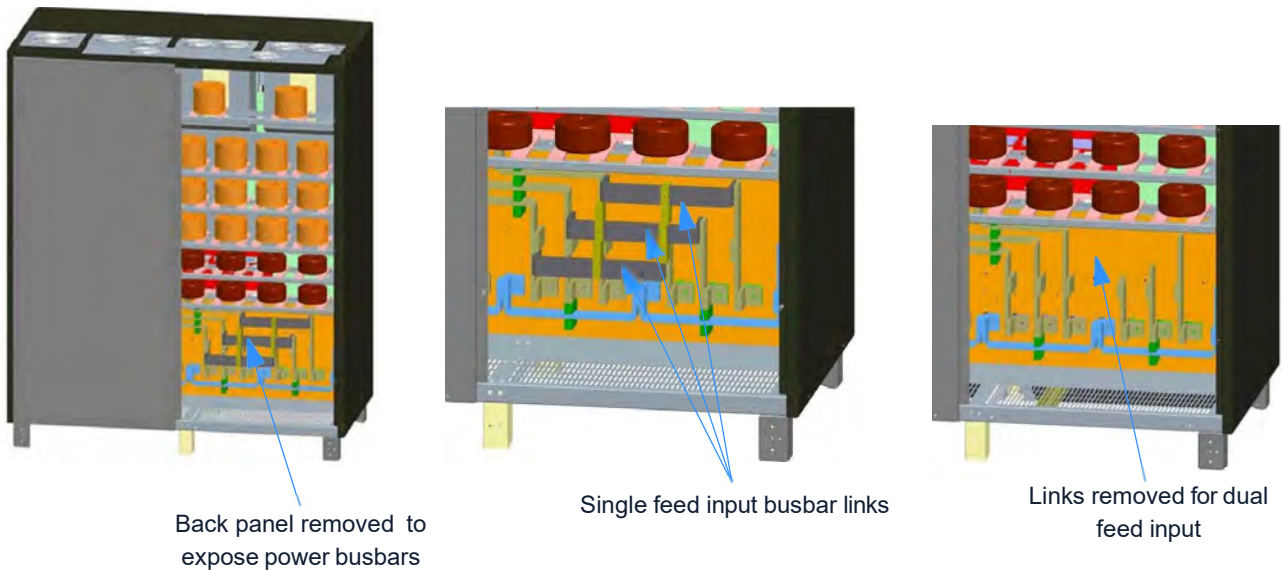

Figure 3.21 Input configuration links

1. Gain access to the rear of the UPS module.
2. Remove the 10x M5 screws securing the UPS cabinet's right hand back panel then carefully remove it and stow it safely.
3. Remove the three busbar links identified in Figure 3.21. They are secured by 6x M10 nuts and bolts.
4. When the busbar links are removed, cover the holes exposed in the main busbars by refitting the 6x M10 nuts and tightening them to 5.0 Nm.
5. Refit the UPS right-hand back panel and secure it with the 10xM5 bolts removed earlier, tightening them to 6.0 Nm.

Note: Use the above procedure in reverse order if it is necessary to convert the UPS from a dual feed to single feed input.



WARNING: The UPS must be commissioned by a Rehiko approved engineer. **DO NOT APPLY POWER TO THE UPS BEFORE IT HAS BEEN FULLY COMMISSIONED.**

3.8 Installation of remote monitoring and control facilities

3.8.1 Module communications interface facilities

Each UPS cabinet is fitted with a communications interface board which enables various external monitoring and control applications to be connected to the system to satisfy particular site requirements.

Details of the interface facilities and available options are provided in Chapter 8. Any connected features will be checked by the commissioning engineer when the UPS system is commissioned.



CAUTION: When the UPS is connected to a parallel system a 'parallel control' cable must be connected between each module (JD8). This must be installed and configured by the commissioning engineer; however, depending on the modules' positioning, it may be necessary for the customer to provide any necessary containment. Contact Rehlko for further installation advice if required.

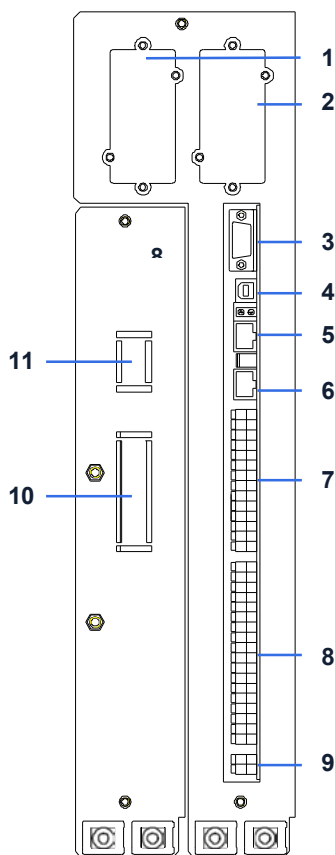

KEY	IDENT	FUNCTION
1	Modem	Slot for optional Modem/Ethernet card only
2	SNMP	Slot for optional SNMP card
3	JD1	RS232 PC Interface on Sub D9 Female
4	USB	RS232 PC Interface on standard USB
5	JR2	RS485 on RJ45 port. Remote panel interface
6	JR1	RS485 on RJ45 port. Multidrop interface
7	X3	Customer wired inputs
8	X2	Volt-free switched alarm/status outputs
9	X1	Castell interlock function
10	JD8	For parallel bus adapter card (JD5/JD6)
11	SW1-9	Multi-cabinet configuration DIP switch

Figure 3.22 UPS Communications Interface Board connectors

4. Operating Instructions (LCD)

This chapter contains the operating instructions using the standard LCD Module Control Panel. If the UPS module is fitted with a TFT Control Panel please refer to the Operating Instructions in Chapter 5.



WARNING: Rehiko will not accept responsibility for the equipment or the safety of any personnel if the UPS system is operated before it has been fully commissioned.

The manufacturer's warranty will be invalidated if power is applied to any part of the UPS system before it has been fully commissioned and handed over to the customer.

4.1 Introduction

4.1.1 Commissioning

The Rehiko PW 6000 (400-500kVA) UPS is a high quality, complex electronic system which must be commissioned by an authorised Rehiko engineer before it is put into use.

The commissioning engineer will:

- check the UPS electrical and mechanical installation, and operating environment
- install and connect the UPS batteries
- check the UPS configuration settings
- check the installation and operation of any optional equipment
- perform a controlled UPS start-up
- fully test the system for correct operation
- provide customer operator training and equipment handover

4.1.2 Operating procedure summary

Under normal circumstances all the UPS modules in a parallel-module system are turned on and operating in their 'on-inverter' mode. If one module fails in a 'redundant module' system the faulty module shuts down but it will not affect the remaining module(s), which will continue to operate normally and provide protected load power. The failed module can then be replaced by a trained UPS service engineer if necessary without affecting the operation of the UPS system.

If a UPS module fails in a 'capacity' rated (or single module) system, the load immediately transfers to the static bypass and will be connected to the unprotected bypass mains power supply.

A parallel-module UPS system requires an external maintenance bypass facility which wraps around the entire UPS system – this is optional in a single cabinet installation. The external maintenance bypass is bespoke to the installation and can be installed in a separate cabinet or switchgear panel (see *paragraph 3.5.3*). If an external maintenance bypass is installed you should familiarise yourself with its operation before using the UPS operating procedures contained in this chapter.

All the switches and control panel operations mentioned in this chapter are identified and described in chapter 2.

The commissioning engineer will hand-over the system in a fully working condition with all the UPS modules turned on and operating in the 'on-inverter' mode (or 'on bypass' if the customer wishes to use the system in ECO mode).

This chapter contains the following procedures:

- *How to start the UPS system from a fully powered-down condition - see paragraph 4.2*
- *How to start the UPS system from the maintenance bypass - see paragraph 4.3 .*
- *How to transfer the load to maintenance bypass - see paragraph 4.4 .*
- *How to shut down the complete UPS system - see paragraph 4.5*
- *Operating in bypass (ECO) mode - see paragraph 4.6*

4.1.3 General warnings and precautions



WARNING: The procedures given below must be performed by a trained operator.



WARNING: When the UPS system is operating on BYPASS or via the MAINTENANCE BYPASS SWITCH, the load supply is unprotected if the bypass mains supply fails. It is essential that the load user is informed of this possibility before you select the BYPASS operating modes.



WARNING: When the UPS is shut down, power is still applied to the UPS input/bypass terminals unless the input/bypass mains is isolated at the UPS supply switchgear panel. In a single module installation it is not permissible to turn off the external input/bypass mains supply when the load is connected via the internal maintenance bypass switch (IA1) as this will also disconnect the load power and under these circumstances the UPS will always contain live mains voltages.



Key Point: In order to reduce the possible effects of any high inrush currents that might occur when the load is initially turned on, we recommend that you power-up the load when the UPS system is operating on maintenance bypass, as described in this procedure.

IMPORTANT NOTE (MAINTENANCE BYPASS SWITCH)

In the following procedures, all references to the 'Maintenance Bypass Switch' apply to the internal maintenance bypass switch (IA1) in the case of a single cabinet if it is not connected to an external maintenance bypass facility.

Where an external maintenance bypass facility is installed (standard in a parallel-module system) all references to the 'Maintenance Bypass Switch' apply to the maintenance bypass switch in the external facility. You should familiarise yourself with the operation of the external maintenance bypass circuit before using the following UPS operating procedures.

4.2 How to start the UPS system from a fully powered-down condition

Initial conditions (on ALL modules in a parallel system):

This procedure assumes the following initial conditions:

- The UPS maintenance bypass switch is open.
- The external UPS output isolation device is open.
- The battery fuses are open.
- The UPS input and bypass mains (split bypass) supplies are turned OFF at the switchgear panel.
- The UPS parallel isolator (IA2) is open.

Power-up the load:

1. Turn ON the UPS system input/bypass mains supply.
 - a. Power will be applied to the UPS module(s), but it will be turned OFF.
2. On the module control panel, verify that:
 - a. The LINE 1 LED is green.
 - b. The BATTERY LED is flashing red.
 - c. All other mimic LEDs are OFF
 - d. The LCD displays LOADOFF, SUPPLYFAILURE.
If necessary press the RESET button to obtain this display.
3. Close the external UPS system output isolation device.
4. Close the UPS maintenance bypass switch (See the IMPORTANT NOTE above)
5. Turn on the load equipment.
 - a. The load is now powered through the maintenance bypass.

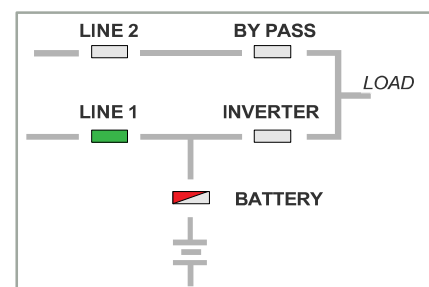

- b. The module control panel mimic indications do not change.
 - c. The LCD displays MANUALBYPISCLOSED.
6. Press the RESET button.
- a. The LCD displays LOADOFF, SUPPLYFAILURE.

Start the UPS module(s):

- 7. Carry out steps 8 to 13 on each UPS module in turn in a parallel-module system.
- 8. On the module control panel, simultaneously press both ON/OFF buttons. The UPS module will begin to power up over approximately 60s.
- 9. On the module control panel, after 60s verify that:
 - a. The LINE 1 LED is green.
 - b. The LINE 2 LED is green.
 - c. The BYPASS LED is green.
 - d. The INVERTER LED is red.
 - e. The BATTERY LED is flashing red.
 - f. The LCD displays LOADNOTPROTECTED.
- 10. Close the external battery fuse.
- 11. On the module control panel, verify that:
 - a. The BATTERY LED flashes green then changes to a solid green within 5 minutes.
- 12. Close the UPS parallel isolator switch (IA2).
- 13. On the module control panel, verify that:
 - a. The LCD displays PARALLEL SW CLOSED.
- 14. Before you continue, ensure that the indications on the module control panels of ALL modules in a parallel-module system are identical, and as described above.

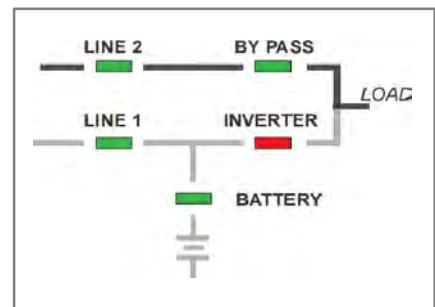
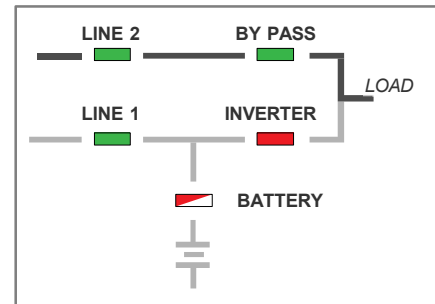

Transfer the load to inverter:

- 15. If the BYPASS LED is green (on ALL modules), open the maintenance bypass switch.

Note: If the BYPASS LED is not green, repeat step 7 then seek trained advice if it still fails to light green.
- 16. On the module control panel:
 - a. Press the UP key once to access the menu system.
 - b. Use the UP /DOWN keys to move the cursor so that it is adjacent to COMMANDS and then press the ENTER key.
 - c. Use the UP /DOWN keys to move the cursor so that it is adjacent to LOAD TO INVERTER and then press the ENTER key.
 - d. The UPS module output should transfer to inverter and the module control panel mimic indications should be as shown here.
- 17. Scroll through the measurements menu and check that the module's input and output supply indications are correct.

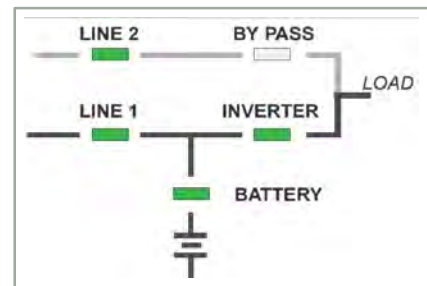

Key Point: The UPS system is now operating in its 'on-inverter' mode and the load is fully protected.

4.3 How to start the UPS system from the maintenance bypass



Key Point: If the load is not already turned on, turn it on now, while the UPS system is operating on maintenance bypass, before you continue with this procedure.

Initial conditions:

This procedure assumes the following initial conditions.

- The UPS input and bypass mains (split bypass) supplies are turned ON at the switchgear panel.
- The external UPS system output isolation device is closed.
- The load equipment is turned on and receiving power through the UPS maintenance bypass.

Powering up the UPS system:

If the UPS system is operating on maintenance bypass it can be powered up using the procedure described in paragraph 4.2 ("How to start the UPS system from a fully powered-down condition") beginning at step 7.

4.4 How to transfer the load to maintenance bypass

The load can be transferred to the maintenance bypass supply, and the UPS modules turned off, when troubleshooting a 'system level' fault or replacing a UPS module in a 'capacity' rated system. This procedure is normally carried out by a trained service engineer and is not usually part of the day-to-day management of the UPS system.



CAUTION: The load is not protected when operating on the Maintenance Bypass.

Initial conditions:

This procedure assumes one of the following initial conditions.

1. The UPS system is operating normally, on-inverter– continue with step 3:

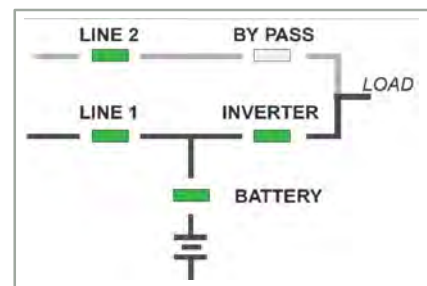

2. The UPS system is operating with the load on bypass due to a system fault, severe overload, loss of redundancy or operating in 'ECO' mode – continue with step 7:

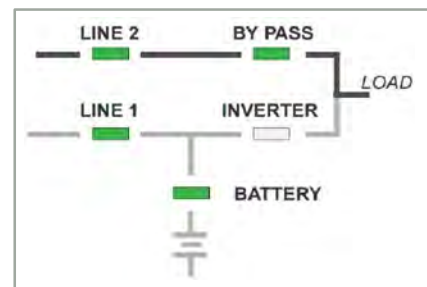

Transfer the UPS to on-bypass mode:

3. On the UPS control panel (on any module in a parallel-module system) press the ENTER key once to access the menu system.
4. Using the UP/DOWN keys, move the cursor so that it is adjacent to COMMANDS and then press the ENTER key.
5. Using the UP/DOWN keys, move the cursor so that it is adjacent to LOAD TO BYPASS and then press the ENTER key.
 - a. The UPS system will transfer the load to static bypass (on all UPS modules in a parallel-module system).
6. *On all modules* check and confirm that:
 - a. The INVERTER LED has extinguished.
 - b. The BYPASS LED is green.
 - c. The LCD displays LOAD NOT PROTECTED.

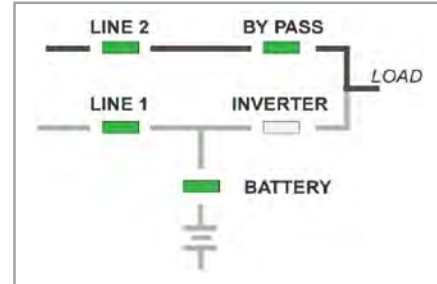

Transfer the load to maintenance bypass:

7. Close the maintenance bypass switch.
8. On the system control panel, verify that:
 - a. The INVERTER LED is red.
 - b. The BYPASS LED is green.
 - c. The module control panel will display MANUAL BYP IS CLOSED.
9. Press the RESET button (*on all UPS modules*) to cancel the audible alarm.

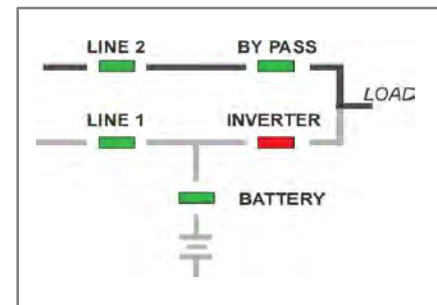

Turn off the UPS module:

10. Carry out steps 11 to 13 on each UPS module in turn.
11. On the module control panel, simultaneously press both ON/OFF buttons and verify that:
 - a. All LEDs turn OFF except for LINE 1 and BATTERY (flashing green).
12. Open the module's parallel isolator (IA2).
13. Open the external battery fuse(s).
 - a. The BATTERY LED will flash red.
14. The load is now connected directly to the mains supply via the maintenance bypass circuit.
15. In the case of a single cabinet installation using the internal
 - a. maintenance bypass switch (IA1), the external UPS input/bypass isolators must remain closed to support the load, and the UPS cabinet's input/bypass and output power terminals will remain live.
 - b. Where an external maintenance bypass facility is used, the UPS system input supply can be turned off – see the operating instructions for the bespoke external maintenance bypass facility for details.

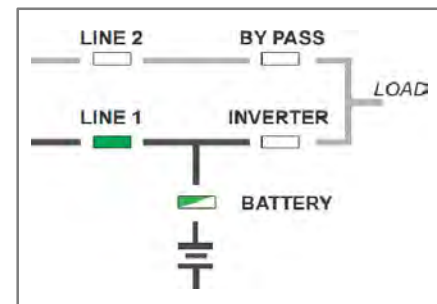

4.5 How to shut down the complete UPS system

The UPS system can be completely shut down if the load does not require power for an extended period of time.

1. Transfer the load to the maintenance bypass and turn OFF the UPS module(s) as described in paragraph 4.4.
2. Isolate all load equipment by opening the external UPS system output isolation device.
3. Open the maintenance bypass switch.

4. Turn OFF the UPS input mains and bypass mains supplies. Where used, refer to the operating instructions for the bespoke external maintenance bypass facility for additional details of how to isolate the UPS mains supply if necessary.
5. The UPS cabinet is now voltage free.

4.6 Operating in bypass (ECO) mode

When operating the UPS system in bypass (ECO) mode, the load is powered normally through the UPS bypass supply and switches to the inverter ('on inverter' mode) automatically if the bypass supply fails.



CAUTION: *There will be a short supply break when the UPS switches to the 'on-inverter' mode, so you should elect to operate in the 'on bypass' mode only if a load can withstand a brief supply break.*

4.6.1 How to Turn ON the UPS system and operate in 'on bypass' (ECO) mode

1. Use the standard operating instructions in paragraph 4.2 but do not perform the "Transfer the load to inverter:" stage (step 15 onwards).

4.6.2 How to Turn OFF the UPS system when operating in 'on bypass' (ECO) mode

1. Use the standard operating instructions in paragraph 4.4 beginning at step 7 – as the load is already operating on bypass.

4.6.3 How to transfer between 'on bypass' (ECO) and 'on inverter' mode

The UPS can be manually switched between the 'on bypass' and 'on inverter' mode through the module control panel load transfer menu.

Transfer the UPS to on-bypass mode:

1. On the UPS control panel (on any module in a parallel-module system) press the ENTER key once to access the menu system.
2. Using the UP/DOWN keys, move the cursor so that it is adjacent to COMMANDS and then press the ENTER key.
3. Using the UP/DOWN keys, move the cursor so that it is adjacent to LOAD TO BYPASS and then press the ENTER key.
 - a. The UPS system will transfer the load to static bypass (on all UPS modules in a parallel-module system).
4. *On all modules* check and confirm that:
 - a. The INVERTER LED has extinguished.
 - b. The BYPASS LED is green.
 - c. The LCD displays LOAD NOT PROTECTED.

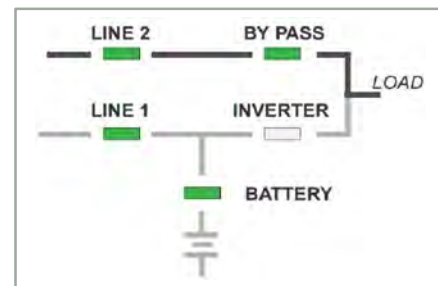

Transfer from 'on bypass' to 'on inverter' mode:

5. If the BYPASS LED is green (on ALL modules), open the maintenance bypass switch.

Note: If the BYPASS LED is not green, seek trained advice if it still fails to light green.
6. On the module control panel:
 - a. Press the UP key once to access the menu system.
 - b. Use the UP/DOWN keys to move the cursor so that it is adjacent to COMMANDS and then press the ENTER key.
 - c. Use the UP/DOWN keys to move the cursor so that it is adjacent to LOAD TO INVERTER and then press the ENTER key.
 - d. The UPS module output should transfer to inverter and the module control panel mimic indications should be as shown here.

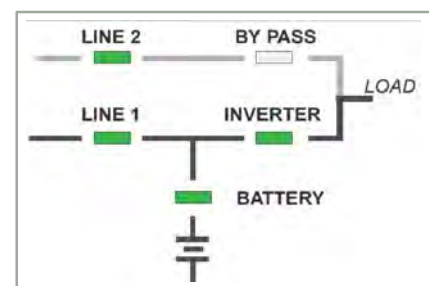

5. Operating Instructions (TFT)

This chapter contains the operating instructions using the TFT Display Panel. If the UPS module is fitted with an LCD Control Panel please refer to the Operating Instructions in Chapter 4.



WARNING: Rehiko will not accept responsibility for the equipment or the safety of any personnel if the UPS system is operated before it has been fully commissioned.

The manufacturer's warranty will be invalidated if power is applied to any part of the UPS system before it has been fully commissioned and handed over to the customer.

5.1 Introduction

5.1.1 Commissioning

The Rehiko PW 6000 (400-500kVA) UPS is a high quality, complex electronic system which must be commissioned by an authorised Rehiko engineer before it is put into use.

The commissioning engineer will:

- check the UPS electrical and mechanical installation, and operating environment
- install and connect the UPS batteries
- check the UPS configuration settings
- check the installation and operation of any optional equipment
- perform a controlled UPS start-up
- fully test the system for correct operation
- provide customer operator training and equipment handover

5.1.2 Operating procedure summary

Under normal circumstances all the UPS modules in a parallel-module system are turned on and operating in their 'on-inverter' mode. If one module fails in a 'redundant module' system the faulty module shuts down but will not affect the remaining module(s), which will continue to operate normally and provide protected load power. The failed module can then be replaced by a trained UPS service engineer if necessary without affecting the operation of the UPS system.

If a UPS module fails in a 'capacity' rated (or single module) system, the load immediately transfers to the static bypass and will be connected to the unprotected bypass mains power supply.

A parallel-module UPS system requires an external maintenance bypass facility which wraps around the entire UPS system – this is optional in a single cabinet installation. The external maintenance bypass is bespoke to the installation and can be installed in a separate cabinet or switchgear panel (see *paragraph 3.5.3*). If an external maintenance bypass is installed you should familiarise yourself with its operation before using the UPS operating procedures in this chapter.

All the switches and control panel operations mentioned in this chapter are identified and described in chapter 2.

The commissioning engineer will hand-over the system in a fully working condition with all the UPS modules turned on and operating in the 'on-inverter' mode (or 'on bypass' if the customer wishes to use the system in ECO mode).

This chapter contains the following procedures:

- *How to turn on the UPS system from a fully powered-down condition - see paragraph 5.2*
- *How to start the UPS system from the maintenance bypass - see paragraph 5.3*
- *How to transfer the load to the maintenance bypass and turn OFF the UPS - see paragraph 5.4*
- *How to shut down the complete UPS system - see paragraph 5.5*
- *Operating in bypass (ECO) mode - see paragraph 5.6*

5.1.3 General warnings and precautions



WARNING: The operating procedures given below must be performed by a trained operator.



WARNING: When the UPS system is operating on BYPASS or via the MAINTENANCE BYPASS SWITCH, the load supply is unprotected if the bypass mains supply fails. It is essential that the load user is informed of this possibility before you select a BYPASS operating mode.



WARNING: When the UPS is shut down, power is still applied to the UPS input/bypass terminals unless the input/bypass mains is isolated at the UPS supply switchgear panel. In a single module installation it is not permissible to turn off the external input/bypass mains supply when the load is connected via the internal maintenance bypass switch (IA1) as this will also disconnect the load power. Under these circumstances the UPS will ALWAYS contain live mains voltages.



Key Point: To reduce the possible effects of any high inrush currents that might occur when the load is initially turned on, we recommend that you power-up the load when the UPS system is operating on maintenance bypass, as described in the start-up procedure.



Key Point: Depending on the model of the TFT assembly fitted to your UPS, the display may be slightly different to that shown in this chapter. In particular the 'rectifier' power block might be labelled as 'booster.' These two terms are interchangeable and do not imply any variation in function or operation.

IMPORTANT NOTE (MAINTENANCE BYPASS SWITCH)

In the following procedures, all references to the 'Maintenance Bypass Switch' apply to the internal maintenance bypass switch (IA1) in the case of a single cabinet if it is not connected to an external maintenance bypass facility.

Where an external maintenance bypass facility is installed (standard in a parallel-module system) all references to the 'Maintenance Bypass Switch' apply to the maintenance bypass switch in the external facility. You should familiarise yourself with the operation of the external maintenance bypass circuit before using the following UPS operating procedures.

Note: As you step through these operating procedures several events will be logged in the UPS events register, accompanied by the appearance of the WARNING triangle in the TFT Header bar and, in some cases, accompanied by an audible alarm. When this occurs you can cancel the audible warning by pressing the triangular warning symbol. The TFT Control Panel is described in paragraph 2.6

5.2 How to turn on the UPS system from a fully powered-down condition

There are three distinct stages to this procedure:

1. Place the system on 'maintenance bypass' and turn on load equipment.
2. Transfer the load from the maintenance bypass to the UPS internal static bypass line.
3. Finally, transfer the load to the UPS inverter.

This procedure assumes the following initial conditions:

- The UPS load is turned off
- The UPS maintenance bypass switch is open
- The UPS external output isolation device is open
- The battery fuses are open
- The UPS input and bypass mains (split bypass) supplies are turned OFF at the supply switchgear panel
- The UPS parallel isolator (IA2) is open

5.2.1 Power-up the load on the maintenance bypass:

1. Repeat step 2 to 7 for every module in a parallel-module system.
2. Turn ON the UPS system input/bypass mains supply.
 - a. Power will be applied to the UPS module, but it will be turned OFF.
 - b. The TFT control panel will initialise and the display will turn on after a few seconds.
3. On the TFT control panel, verify that:
 - a. LOAD OFF status is displayed in the header bar.
 - b. The mimic screen indicates the input to the rectifier as green, but the rectifier and inverter are inhibited (red).
 - c. The battery indication is yellow (battery not connected).

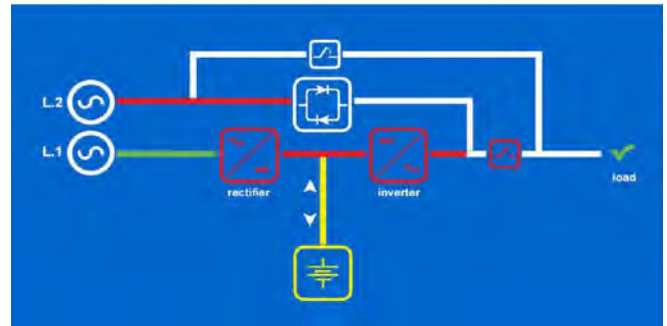

Note: In the above illustration the UPS parallel isolator (IA2) is shown as a red, open switch contact. However in a single module installation IA2 is not monitored and it is always depicted as a green, closed contact.

4. Press the ON/OFF button on the display header bar, and confirm the ON selection in the pop-up box.
 - a. The UPS module will turn ON and automatically close the static bypass.
5. On the TFT control panel, verify that:
 - a. LOAD NOT PROTECTED status is displayed in the display header.
 - b. The mimic screen indicates the rectifier and static bypass are operating (green).
 - c. The inverter is OFF (white)
 - d. IA2 is open – so there is no power connected to the UPS output.

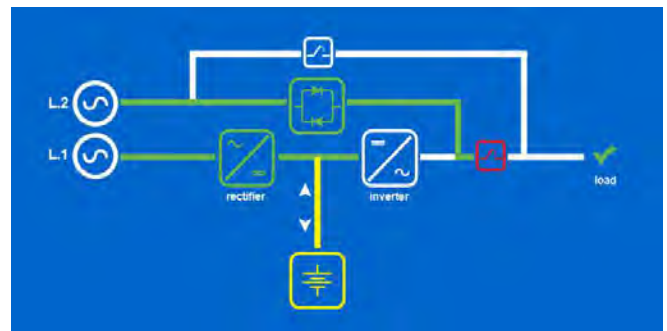

6. Close the battery fuses.
 - a. The battery will be connected and begin charging.
7. On the TFT control panel, verify that:
 - a. The battery line and the battery charge indicator arrowhead changes to green.
8. Close the UPS external output isolation device (for ALL modules in a parallel-module system).

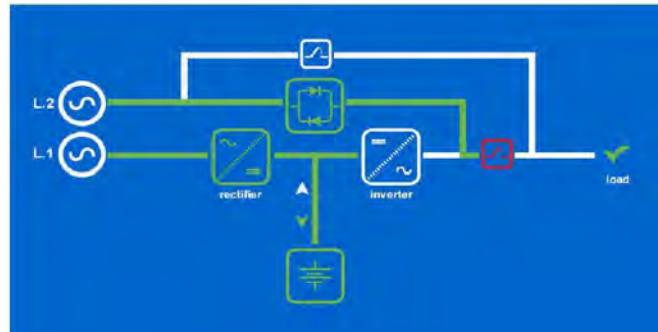

9. Close the maintenance bypass switch.
 - a. The bypass supply will now be connected to the UPS output terminals.
10. On the TFT control panel, verify that:
 - a. LOAD NOT PROTECTED status is displayed in the display header.
 - b. Bypass switch is closed (yellow).
 - c. The bypass line connecting the bypass supply (L2) to the UPS output is yellow.
 - d. The inverter is locked-out (red).
11. Turn ON the UPS load equipment.

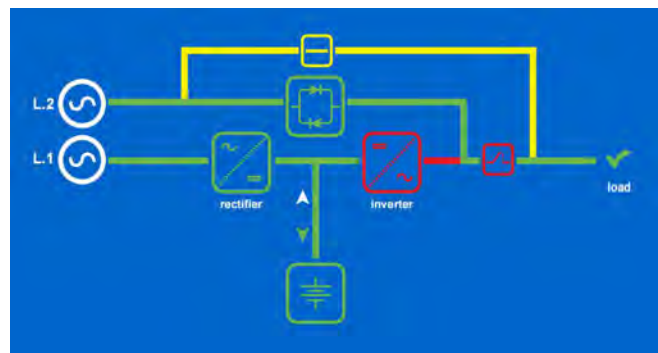

Key Point: The load is now fully powered up but connected to the maintenance bypass line and is therefore unprotected against any supply aberrations.

5.2.2 Transfer the load to the static bypass line:

12. Carry out steps 13 and 14 on each UPS module in turn in a parallel-module system.
13. Close the parallel isolator (IA2).
 - a. The load is now connected to the static bypass line in parallel with the maintenance bypass.
14. On the TFT control panel, verify that:
 - a. The parallel isolator switch icon is shown closed and changed to green.

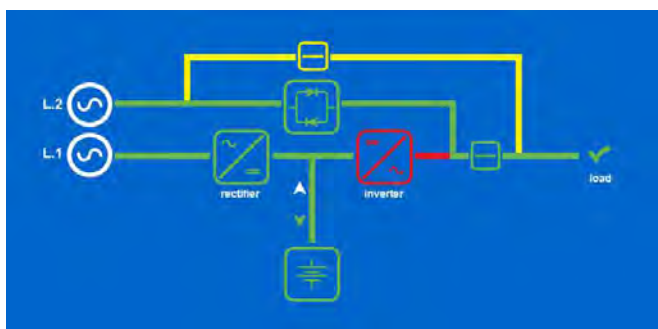

WARNING: For a parallel-module system, do not proceed if the TFT mimic indication on any module is not as shown.

15. Open the maintenance bypass switch.
 - a. The load is now powered via the static bypass.
16. On the TFT control panel, verify that:
 - a. The maintenance bypass switch is OPEN (white).
 - b. The inverter symbol has changed from red (locked out) to white (OFF).

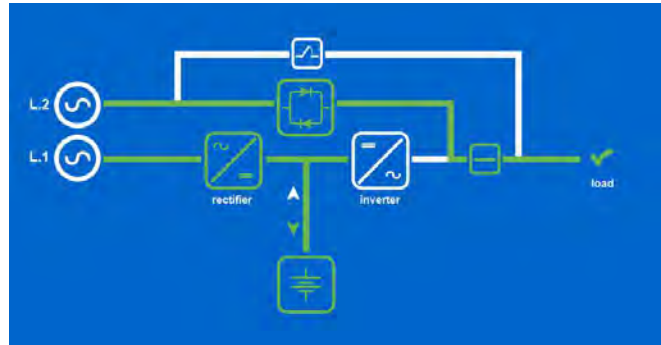

CAUTION: Before you continue, ensure that the indications on the TFT control panels of ALL modules in a parallel-module system are identical, and as shown above.

5.2.3 Transfer the load to inverter:

17. Press the Home screen icon on the display header (on any one module in a parallel-module system).
18. From the Home screen press the Commands icon.
19. Select Load to Inverter.
 - a. The static bypass will turn off and the load will transfer to the inverter without a supply break.
20. On the TFT control panel, verify that:
 - a. The static bypass is turned off (white)
 - b. The inverter is turned on (green).
 - c. The battery is being charged.
 - d. LOAD PROTECTED status is displayed in the header bar.
21. Scroll through the measurements menu and check that the module's input and output supply indications are correct.

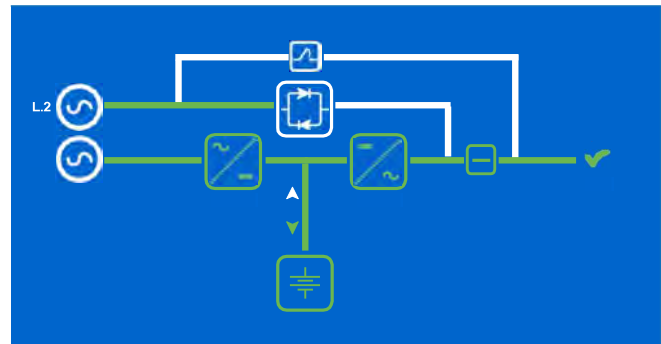

Key Point: The UPS system is now operating in its 'on-inverter' mode and the load is fully protected.

5.3 How to start the UPS system from the maintenance bypass

This procedure can be used to start the UPS system where the load is already connected to the maintenance bypass supply. In the case of a single module system using the internal maintenance bypass switch (IA1), the UPS input/bypass supplies will already be turned ON; however, when dealing with a parallel-module system (or a single module using an external maintenance bypass facility) these supplies might be turned OFF.

There are three distinct stages to this procedure:

1. Turn ON the UPS and close the static bypass.
2. Transfer the load from the maintenance bypass to the UPS internal static bypass line.
3. Finally, transfer the load to the UPS inverter.

This procedure assumes the following initial conditions:

- The UPS module(s) is turned OFF
- The external UPS system output isolation device is closed.
- The UPS parallel isolator (IA2) is open.
- The load equipment is turned on and receiving power through the UPS maintenance bypass.



Key Point: If the load is not already turned on, turn it on now, while the UPS system is operating on maintenance bypass, before you continue with this procedure.

5.3.1 Power up the UPS system:

1. Turn ON the UPS system input/bypass mains supply if it is not already ON.
2. Press the ON/OFF button on the display header bar, and confirm the ON selection in the pop-up box.
 - a. The UPS module will turn ON and automatically close the static bypass.
3. On the TFT control panel, verify that:
 - a. LOAD NOT PROTECTED status is displayed in the display header.
 - b. The mimic screen indicates the static bypass is closed (yellow).
 - c. The rectifier and static bypass are operating (green).
 - d. The inverter is locked out (red).
 - e. The battery indication is yellow (battery not connected).
 - f. IA2 is open, so the only power connected to the UPS output is derived from the maintenance bypass line.

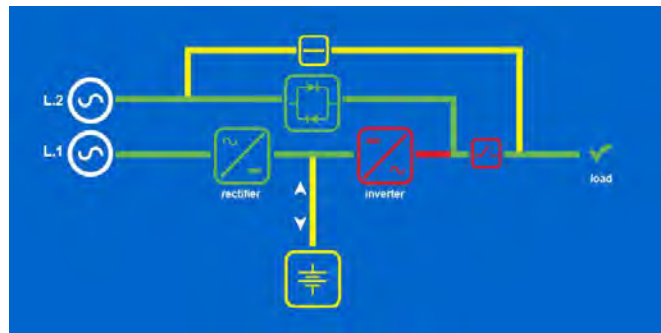

4. Close the battery fuses.
 - a. The battery will be connected and begin charging.
5. Close the UPS parallel isolator (IA2).
6. On the TFT control panel, verify that:
 - a. The battery line and the battery charge indicator arrowhead changes to green.
 - b. The parallel isolator switch icon is shown closed and changes to green.
7. Repeat step 1 to 6 for each module in a parallel-module system.

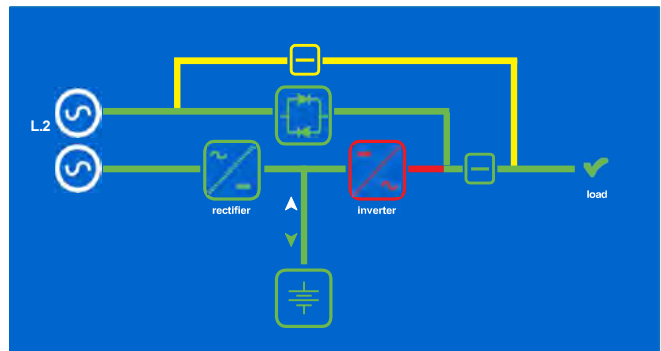



CAUTION: Before you continue, ensure that the indications on the TFT control panels of ALL modules in a parallel-module system are identical, and as shown above.

5.3.2 Transfer the load to the static bypass line:

8. Open the maintenance bypass switch.
 - a. The load is transferred to the static bypass line.
9. On the TFT control panel(s), verify that:
 - a. The maintenance bypass switch is open and the maintenance bypass line changes to white.
 - b. The inverter symbol changes from red (locked out) to white (OFF).

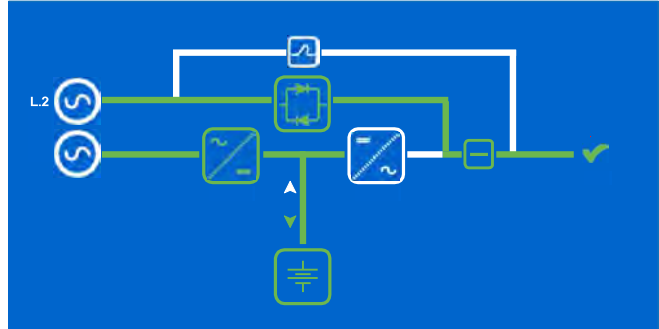

5.3.3 Transfer the load to inverter:

10. Press the Home screen button on the display header.
11. From the Home screen press the Commands button.
12. Select Load to Inverter.
 - a. The static bypass will turn off and the load will transfer to the inverter without a supply break.
13. On the TFT control panel(s), verify that:
 - a. The static bypass is turned off (white)
 - b. The inverter is turned on (green).
 - c. The battery is being charged.
 - d. LOAD PROTECTED status is displayed in the header bar.
14. Scroll through the measurements menu and check that the module's input and output supply indications are correct.

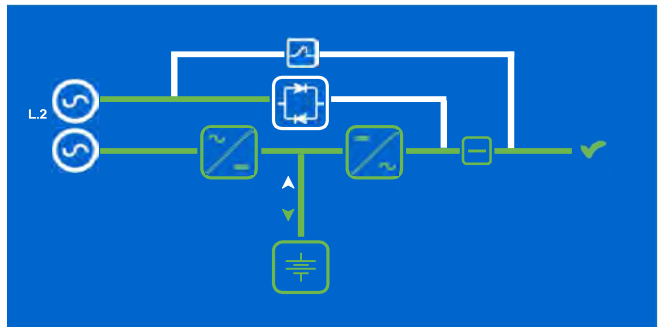

Key Point: The UPS system is now operating in its 'on-inverter' mode and the load is fully protected.

5.4 How to transfer the load to the maintenance bypass and turn OFF the UPS

The load can be transferred to the maintenance bypass supply, and the UPS module turned off, when troubleshooting a 'system level' fault or if the UPS processed power is not required for a period of time. This procedure is normally carried out by a trained service engineer and is not usually part of the day-to-day management of the UPS system.



CAUTION: The load is not protected when operating on the Maintenance Bypass.

Initial conditions:

This procedure assumes one of the following initial conditions.

1. The UPS system is operating normally, with the load powered from the inverter – start the procedure at paragraph 5.4.1.

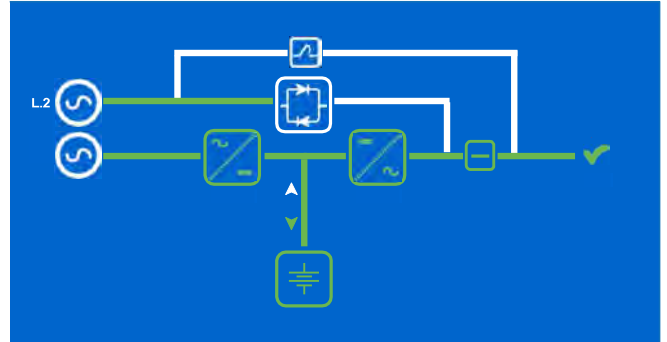

2. The UPS system is operating with the load on bypass due to a system fault, severe overload, loss of redundancy, or operating in 'ECO' mode – start the procedure at paragraph 5.4.2.

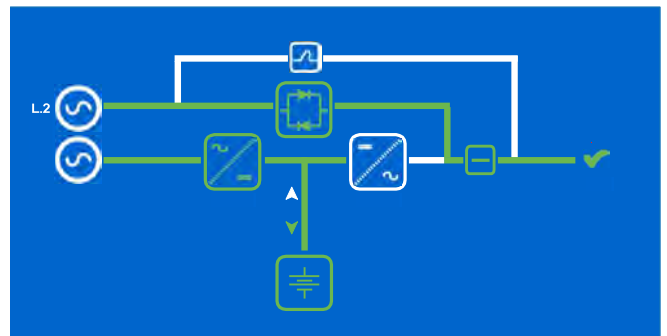

5.4.1 Transfer the load to the static bypass:

3. Press the Home screen button on the display header.
4. From the Home screen press the Commands button.
5. Select Load to bypass.
 - a. The inverter will turn off and the load will transfer to the static bypass line.
6. On the TFT control panel(s), verify that:
 - a. The static bypass is turned ON (green)
 - b. The inverter is turned OFF (green).
 - c. The battery is being charged.
 - d. LOAD NOT PROTECTED status is displayed in the header bar.

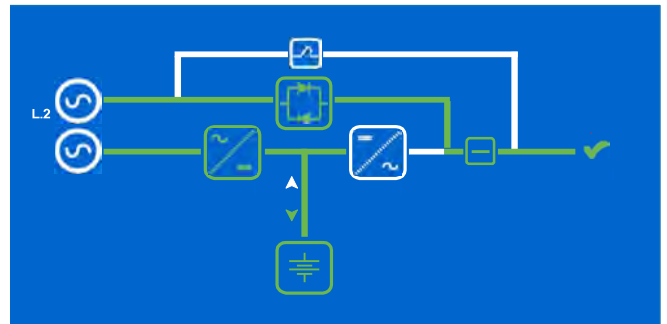

5.4.2 Transfer the load to the maintenance bypass:

7. Close the maintenance bypass switch.
 - a. The load will transfer to the maintenance bypass line connected in parallel with the static bypass line.
8. On the TFT control panel(s), verify that:
 - a. The maintenance bypass is closed (yellow).
 - b. The inverter is turned locked out (red).
 - c. The battery is being charged.

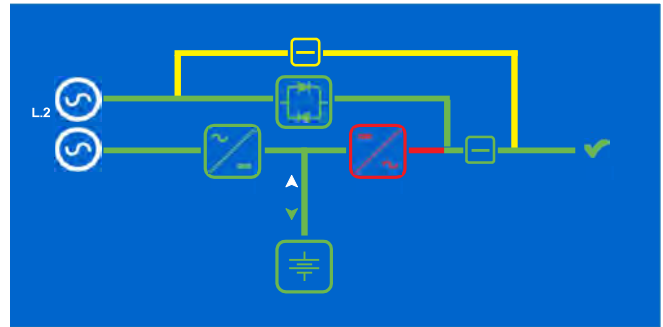

9. Open the battery fuses.
10. Open the UPS parallel isolator (IA2).
11. On the TFT control panel, verify that:
 - a. The battery line changes to yellow.
 - b. The parallel isolator switch icon is shown open and changes to red.

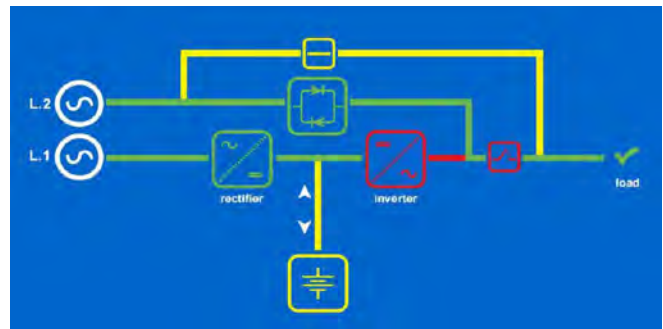

5.4.3 Turn OFF the UPS

12. Press the ON/OFF button on the display header bar, and confirm the OFF selection in the pop-up box.
 - a. The UPS module will turn OFF.
13. On the TFT control panel, verify that:
 - a. LOAD NOT PROTECTED status is displayed in the header bar.
 - b. The mimic screen indicates the rectifier and inverter are inhibited (red).

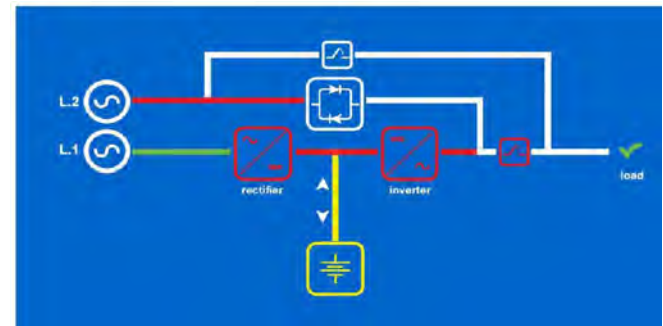

WARNING: If load power is still required via the maintenance bypass, do not turn off the UPS input/bypass mains supply when using the internal maintenance bypass switch (IA1) in a single module UPS system otherwise you will lose the supply.

5.5 How to shut down the complete UPS system

The UPS system can be completely shut down if the load does not require power for an extended period of time.

1. Transfer the load to the maintenance bypass and turn OFF the UPS module(s) as described in paragraph 5.4.
2. Isolate all load equipment by opening the individual load switches and external UPS system output isolation device(s).
3. Open the maintenance bypass switch.
4. Turn OFF the UPS input mains and bypass mains supplies. Where used, refer to the operating instructions for the bespoke external maintenance bypass facility for additional details of how to isolate the UPS mains supply completely if necessary.
5. The UPS cabinet is now voltage free.

5.6 Operating in bypass (ECO) mode

When operating the UPS system in bypass (ECO) mode, the load is powered normally through the UPS static bypass supply and switches to the inverter ('on inverter' mode) automatically if the bypass supply fails.



CAUTION: There will be a short supply break when the UPS switches to the inverter mode, so you should only choose to operate in the 'on bypass' (ECO) mode if the connected load can withstand a brief supply break.

5.6.1 How to Turn ON the UPS system and operate in (ECO) mode

When starting from a fully powered down condition

1. Use the standard operating instructions in paragraph 5.2 but do not perform paragraph 5.2.3 onwards.

When starting from being on the maintenance bypass

1. Use the standard operating instructions in paragraph 5.3 but do not perform paragraph 5.3.3 onwards.

5.6.2 How to transfer the load to the maintenance bypass and Turn OFF the UPS system

1. Use the standard operating instructions in paragraph 5.4 starting at paragraph 5.4.2 onwards.

5.6.3 How to transfer between 'on bypass' (ECO) and 'on inverter' mode

The UPS can be manually switched between the 'on bypass' and 'on inverter' mode through the TFT control panel commands menu.

Transfer the load to inverter:

2. Press the Home screen button on the display header.
3. From the Home screen press the Commands button.
4. Select Load to Inverter.
 - a. The static bypass will turn off and the load will transfer to the inverter without a supply break.
5. On the TFT control panel(s), verify that:
 - a. The static bypass is turned off (white)
 - b. The inverter is turned on (green).
 - c. The battery is being charged.
 - d. LOAD PROTECTED status is displayed in the header bar.

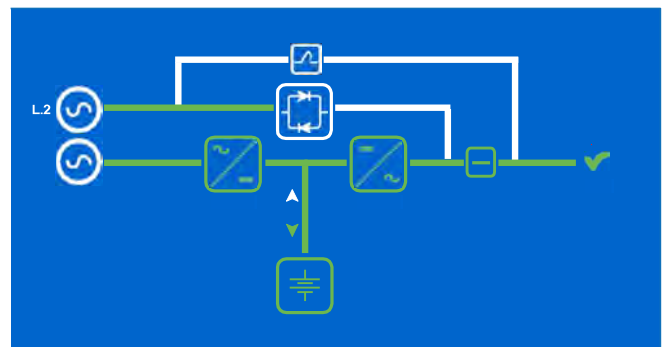

Transfer the UPS to on-bypass mode:

1. Press the Home screen button on the display header.
2. From the Home screen press the Commands button.
3. Select Load to bypass.
 - a. The inverter will turn off and the load will transfer to the static bypass line.
4. On the TFT control panel(s), verify that:
 - a. The static bypass is turned ON (green)
 - b. The inverter is turned OFF (green).
 - c. The battery is being charged.
 - d. LOAD NOT PROTECTED status is displayed in the header bar.

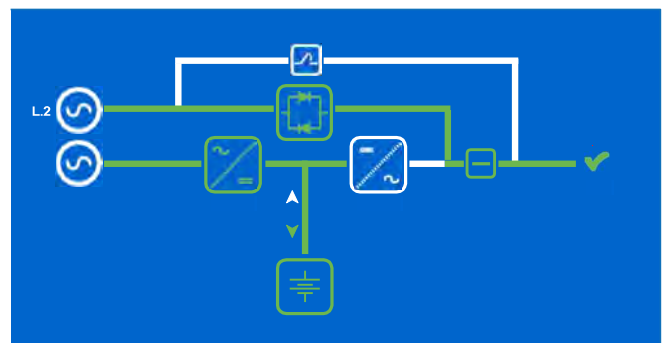

6. Maintenance

6.1 Introduction



WARNING: The procedures described in this chapter must be performed by an authorised electrician who has received the appropriate level of training on this UPS system.

The UPS maintenance requirements of the user are minimal as there are no user-serviceable parts contained within the UPS cabinet. However, the UPS contains life limited components that require to be replaced at regular intervals, we recommend that the UPS and batteries are inspected and checked for calibration on a 6 monthly basis as part of a preventative maintenance schedule to maximise the system's working life and reliability.

6.2 User responsibilities

The UPS equipment should be inspected daily to ensure that the environment in which it is operating is kept cool and dust free at all times, and that the operating temperature and humidity is within the limits given in the specifications chapter of this manual. The UPS equipment should also be maintained in accordance with the manufacturer's recommendation and any life limited components replaced at the required intervals and critical updates are performed.

Any active alarm or status indication that indicates that the UPS is not functioning correctly should be dealt with immediately by referring to the troubleshooting chapter of this manual or contacting the manufacturer's service desk.

Routine maintenance



WARNING: When working inside the UPS cabinet there is a risk of exposure to potentially lethal AC and DC voltages. All work that requires internal cabinet access must be carried out by trained personnel only.

The commissioning engineer will leave a service record book inside the front of the UPS which will be used to log the UPS future service history. To ensure optimum UPS operation we recommend that the system's operating parameters are checked and logged every six months, and recalibrated where necessary.

Preventative maintenance inspections form an integral part of all Extended Warranty Agreements (maintenance contracts) offered by Rehiko. For further details on Extended Warranty Agreements see page 19.

A preventative maintenance inspection of the following:

- | | |
|--|--|
| • Site/environment conditions | • Battery status and condition |
| • Integrity of electrical installation | • Load characteristics |
| • Cooling airflow | • Integrity of alarm and monitoring systems |
| • Rectifier /booster operation and calibration | • Correct operation of all installed options |
| • Inverter operation and calibration | • Manufacturer recommended updates |
| • Static switch operation | • Condition of life limited components |

6.3 Battery testing

A battery test can be initiated from the UPS control panel and takes approximately 3 minutes to complete.

The test, which can be carried out independent of the operating mode (off-line or on-line) and whether or not the load is connected, should be undertaken only if there are no alarm conditions and the battery is initially fully charged.

7. Troubleshooting

7.1 Alarms

Numerous UPS operating conditions are monitored and will initiate an alarm or warning event notification on the UPS control panel if an error is detected or an abnormal condition occurs. In the event of an alarm you should:

1. Silence the audible warning.
2. Identify the cause of the alarm by inspecting the UPS module control panel 'event' register.
3. Interpret the cause of the alarm (see below) and seek assistance from your nearest service centre if the cause of the alarm is beyond simple rectification.

IMPORTANT NOTE

Certain alarm conditions may 'latch-on' even after the cause of the alarm is no longer present. For example, if there is a brief mains failure during unattended operation the MAINS FAIL alarm will activate and it may still indicate a fault condition even after the mains supply has returned to normal. Similarly, a LOAD ON BYPASS alarm might have been caused by an inverter overload

If any alarm appears, the first action to take is to attempt to RESET it.

If the alarm indication resets then it was probably caused by a transient condition; the UPS has responded correctly and no further action is required. Investigative action is necessary if it is not possible to reset the alarm, or if the alarm is repetitive, which may require assistance from the UPS Limited Service Department.

7.2 LCD Control panel

The LCD Control panel is described on page 11, "*Module Control Panel (standard LCD)*". If an alarm occurs the red ALARM led will flash accompanied by an audible warning:

1. Cancel the audible warning by pressing the RESET button. If the alarmed condition was transient the audible warning will stop and the red warning light will extinguish. If the red warning remains ON it indicates that the cause of the alarm is still present and must be investigated.
2. Investigate the cause of the alarm by making a note of the EVENT LOG, which is accessed from the MAIN MENU – this will present a list of time-stamped events that took place preceding the detected alarm.
3. Access the MEASUREMENTS screen from the MAIN MENU and note the UPS input/output/battery parameters.
4. Refer to the troubleshooting table below for possible fault resolutions and seek advice if necessary.

7.3 TFT Control panel

The TFT Control panel is described on page 15, "*TFT Module control panel*".

If an alarm occurs the amber WARNING icon will be displayed in the control panel header bar accompanied by an audible warning:

1. Cancel the audible warning by pressing the WARNING icon. This will silence the audible warning and open the EVENTS screen, which will present a list of time-stamped events that took place immediately preceding the detected alarm.
2. Investigate the cause of the alarm by making a note of the EVENTS in the EVENT LOG immediately preceding the alarm.
3. Pressing the Home screen icon on the display header bar then selecting Measures. This will open the metering screens from which you can observe and note the value of the UPS input/output/battery parameters etc.

Refer to the troubleshooting table below for possible fault resolutions and seek advice if necessary.

7.4 Troubleshooting table

ALARM CONDITION	MEANING	SUGGESTED SOLUTION
UPS FAULT	There is a fault in the UPS and therefore normal operation cannot be guaranteed	Call the authorised service centre for assistance
MAINS BYP/RECT FAULT	Mains power supply is outside prescribed tolerance	The input power to UPS is too low or missing. If site power appears to be OK, check the input circuit breakers etc. supplying the UPS.
OUTPUT SHORT	There is a short circuit at the output of UPS (on load side)	Check all output connections and repair as required
OVERLOAD	Load exceeds the UPS rated power	Identify which piece of equipment is causing the overload and remove it from the UPS. Do not connect laser printers, photocopiers, electric heaters, kettles etc. to the UPS.
OVERTEMPERATURE	UPS temperature has exceeded the allowed value	Check the temperature of the UPS is less than 30° C. If the ambient temperature is normal call the authorised service centre for assistance.
BATTERY CHARGER OFF	The attached battery and the battery charger set-up do not correspond or battery charger fault	Call the authorised service centre for assistance.
INVERTER FAULT	Inverter is faulty	Call the authorised service centre for assistance.
SYNCHRON FAULT	The inverter and mains are not synchronised	The frequency of the input voltage to the UPS is outside operational limits and the UPS static bypass has been temporarily disabled.
BATTERY IN DISCHARGE	Battery is near end of autonomy	Shut down the load connected to UPS before the UPS switches itself off to protect its batteries
MANUAL BYP IS CLOSED	Maintenance bypass closed. Load supplied by mains	This alarm is only displayed if the UPS is on maintenance bypass

7.5 Contacting service

Rehiko has a service department dedicated to providing routine maintenance and emergency service cover for your UPS. If you have any queries regarding your UPS please contact us.

UK

www.ups.rehiko.co.uk

ukservice.ups@rehiko.com

uktechnicalsupport.ups@rehiko.com

uksales.ups@rehiko.com

ukservicesales.ups@rehiko.com

Rehiko web site

Service department – booking service, fault reporting etc.

Technical queries

Hardware sales

Extended warranty agreements etc

IRELAND

www.ups.rehiko.ie

ieinfo.ups@rehiko.com

Rehiko web site

Service department, technical queries, hardware sales and extended warranty agreements

SINGAPORE

www.ups.rehiko.sg

salesups.sg@rehiko.com

serviceups.sg@rehiko.com

Rehiko web site

Hardware sales

Contract customer support, maintenance contracts renewals

8. Options

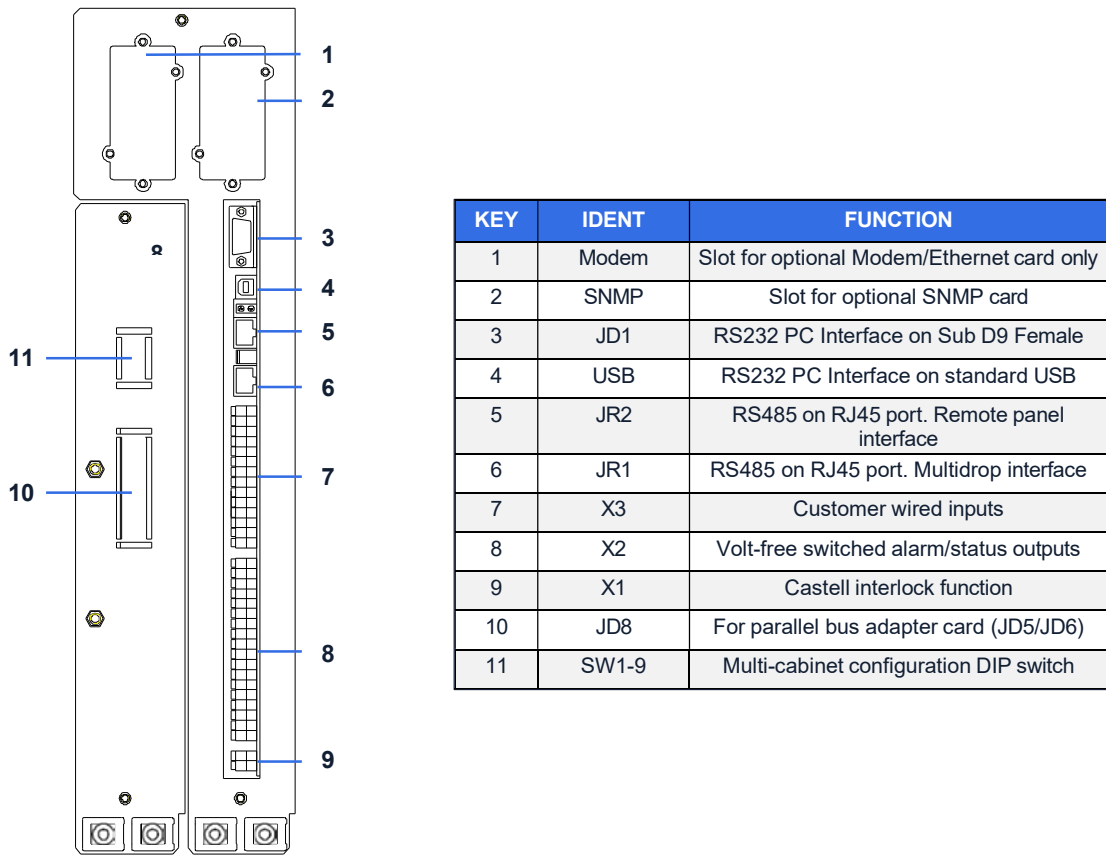

Figure 8.1 UPS Interfacing connectors

8.1 Introduction

Each UPS cabinet is fitted with a communication interface board, as shown in Figure 8.1, which enables various external monitoring and control applications to be connected to the UPS to satisfy particular site requirements.

These interfaces are described below.

- RS232 Computer serial interface – USB & JD1 (see paragraph 8.2)
- RS485 Interface for multidrop – JR1 (see paragraph 8.3)
- Dry port customer interface – X2, X3 (see paragraph 8.4)
- SNMP/ Modem slots for remote monitoring/control – (see paragraph 8.5)

8.2 Serial RS232 Computer interface – USB & JD1 (Smart Port)

JD1 is a 9-pin, female, D-type connector which can be connected to a computer for monitoring purposes. When used in conjunction with suitable software, it allows continuous monitoring of the input mains voltage and UPS status, and displays various status messages if there any UPS system changes.

This port can be connected using standard computer serial communications cable wired as shown below in Figure 8.2. The maximum length of the RS232 cable is 15m.

The USB port on the customer interface board is connected in parallel with JD1 and outputs the same data stream.

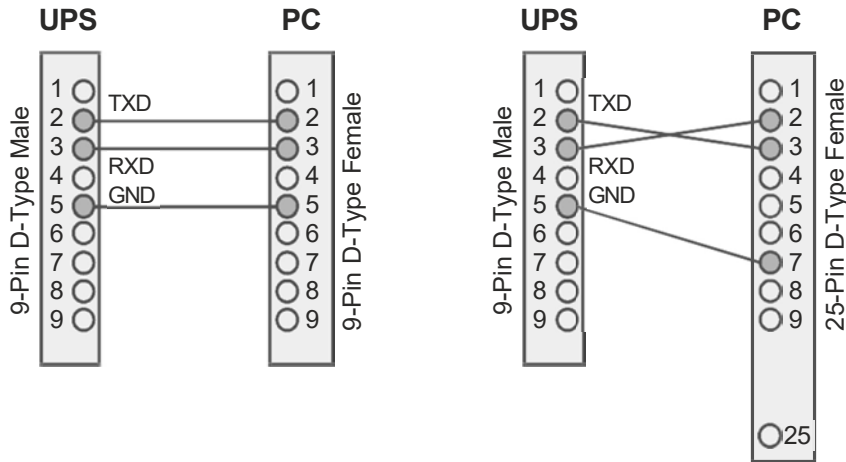

Figure 8.2 Connector Cable - PC Serial Port

8.3 RS485 Interface for multidrop – JR1

When used with the Multidrop connection kit, the computer interface (JR1) provides an intelligent RS485 serial port that allows a computer to access information from all modules connected in a parallel system.

The optional 'Multidrop' feature, which is available only in a parallel system, allows the customer interface board in the 'master' cabinet to collect data/messages from the other system cabinets via the cables connected to JR2. The received data is then processed at a centralised point on the 'master' customer interface board and made available to the user directly on the RS232 port (JD1), from where it can be used to display the system operating parameters and status. It is also transmitted to the SNMP/CS141 card if inserted in the relevant card-slot.



Key Point: When the multidrop feature is used the I/O facilities of the customer interface boards in the 'slave' cabinets are all disabled, but the customer interface board fitted to the 'master' cabinet remains fully functional.

If the multidrop feature is requested, the commissioning engineer will install the required kit of parts and test the system to ensure it is fully functional as part of the UPS commissioning procedure.

8.4 Dry ports customer interface (X1, X2, X3)

Customer I/O interface facilities are made to Phoenix spring terminal blocks (cable 0.2mm² to 1.5mm²) annotated X1, X2 and X3. All voltage-free contacts are rated at 250Vac/8A, 30Vdc/8A, 110Vdc/0.3A, 220Vdc/0.12A.

8.4.1 Dry port connections

	Terminal	Contact	Signal	Display	Function
X3	X3/14	Gnd	Gnd		Battery Temperature Sensing (If connected this input is battery temperature dependent)
	X3/13	In	+3.3 Vdc		
	X3/12	Gnd	Gnd	GENERATOR OPER ON	Customer Specific Input (1) (Default NC = Generator on line)
	X3/11	In	+12 Vdc		
	X3/10	Gnd	Gnd	EXTERNAL O/P BREAKER	When used, both the external output breaker and internal IA2 have to be either open or closed in order to isolate or connect the UPS. Display: PARALLEL_SW_OPEN or PARALLEL_SW_CLOSED
	X3/9	In	+12 Vdc		
	X3/8	Gnd	Gnd	EXT MAN BYP	External Manual Bypass (Default NC = External bypass closed)
	X3/7	In	+12 Vdc		
	X3/6	Out	+12 Vdc		+12 Vdc Power source (max 200 mA)
	X3/5	Gnd	Gnd		
	X3/4	Gnd	Gnd	REMOTE SHUTDOWN	RSD Remote Shut Down Leave jumper JP5 in place if no Remote Shut Down input is connected
	X3/3	In	+12 Vdc		
	X3/2	–		REMOTE SHUTDOWN	RSD Remote Shut Down (For external switch) Max 250Vac/8A, 30Vdc/8A, 110Vdc/0.3A, 220Vdc/0.12A
	X3/1	–			
X2	X2/18	Com			Common
	X2/17	NC			Auxiliary NO
	X2/16	NO			Auxiliary NC
	X2/15	Com	Alarm	COMMON ALARM	Common
	X2/14	NC			No Alarm Condition
	X2/13	NO			Common (System) Alarm active
	X2/12	Com	Status	LOAD ON MAINS	Common
	X2/11	NC			Load NOT On Bypass
	X2/10	NO			Load on Bypass (Mains) active
	X2/9	Com	Alarm	BATT LOW	Common
	X2/8	NC			Battery OK
	X2/7	NO			Battery Low active
	X2/6	Com	Status	LOAD ON INV	Common
	X2/5	NC			Load not On Inverter
	X2/4	NO			Load on Inverter active
	X2/3	Com	Alarm	MAINS OK	Common
	X2/2	NC			Mains not present
	X2/1	NO			Mains Present
X1	X1/2	230Vac	–	EXT MAN BYP	Castell Interlock Function External Manual Bypass closed (230 Vac 2AT)
	X1/1	N	–		

8.4.2 Remote Emergency Power Off (EPO) option

The remote Emergency Power Off (EPO) function is disabled on a standard UPS by default; and if this option is required it must be activated by a hardware code in the **SETUP SERVICE** menu of the module control panel. If you want to add this feature post commissioning please contact your distributor to enable this operation.

The EPO facility comprises a normally-closed circuit connected between terminal X3/3 and X3/4 on the communications interface board (see *Figure 8.3*).

We recommend that a terminal block with linking facilities is installed between the UPS and the remote EPO actuator, as shown. This allows the remote emergency stop circuit to be removed or functionally tested without disturbing the UPS operation when a temporary link is fitted across the terminal block.

1. Use a screened cable with 1 pair (section of wires 0.6 mm²) and maximum length of 100 m.
2. Connect the cable as shown in *Figure 8.3*.

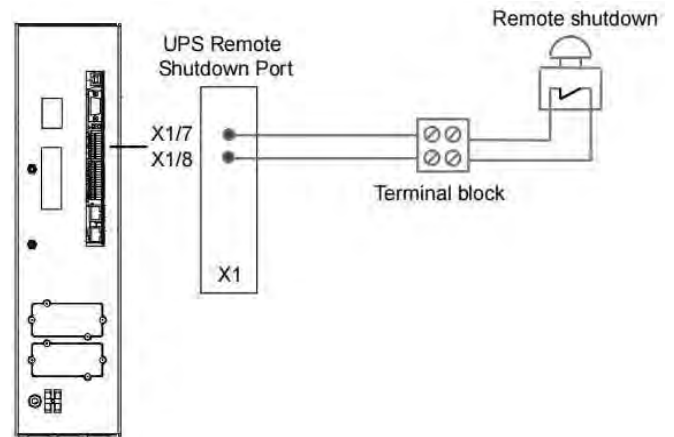

Figure 8.3 Remote emergency stop cabling

8.4.3 Generator ON facilities

The Generator ON input is used to inform the UPS control logic when the UPS input supply is being provided by a standby generator, rather than the utility mains.

When this input is applied, the UPS control logic can be programmed to disable the battery charger and/or static bypass, depending on the generator rating.

The Generator ON input applies a closed contact across X3 terminals 11 and 12 when a standby generator is running and providing the UPS input power.

1. Use a screened cable with 1 pair (section of wires 0.6 mm²) and maximum length of 100 m.
2. Connect the cable as shown in *Figure 8.4*.

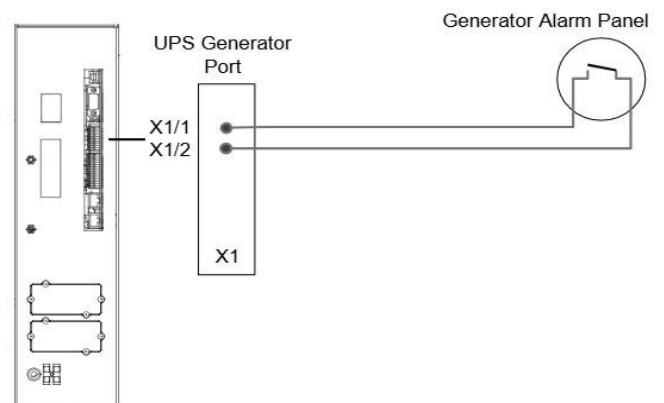

Figure 8.4 Generator ON Connection

8.5 SNMP Card slots

Simple Network Management Protocol (SNMP) is a world-wide, standardised communication protocol that can be used to monitor any network-connected device via a simple control language and display the results in an application running within a standard web browser.

The Rehiko PW 6000 (400-500kVA) contains two SNMP slots; one is designed to house a Modem/Ethernet SNMP adapter card and the other a Modem/GSM adapter. Alternatively, SNMP connectivity can also be implemented using an external SNMP adapter connected to the UPS RS232 output.

An SNMP/Ethernet adapter contains an RJ-45 connector which allows it to be connected to the network using a standard network cable. Once connected, the UPS-Management software agent, which is already installed in the SNMP adapter, then monitors the UPS operating parameters. In a multi-module UPS system the SNMP interface can communicate 'system-wide' data or data for an individual UPS module.

The SNMP card enables event/alarm emails, server shut down (with optional licenses) and other tasks. The SNMP card can also be integrated with BMS software over a local area network (LAN) for SNMP or Modbus information over IP. An optional card enables Modbus over RS485.

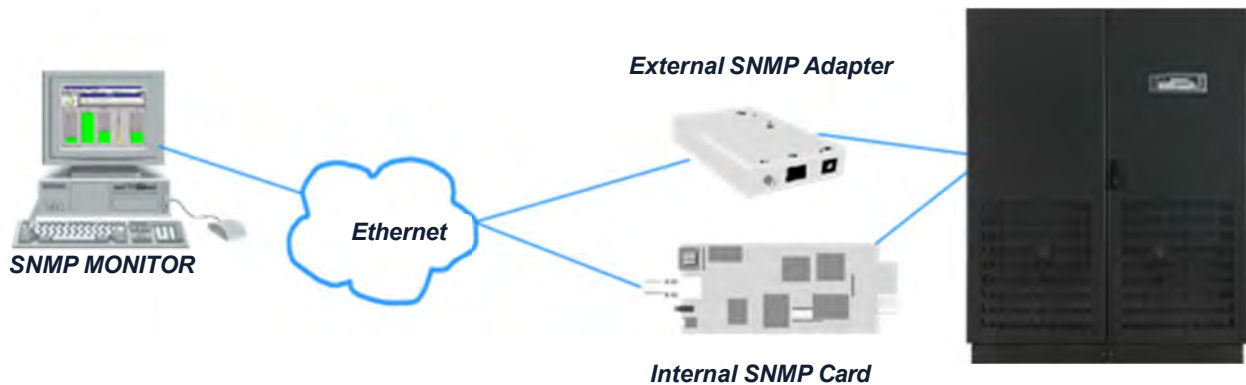



Figure 8.5 SNMP Internal and external adapters

9. Specification

9.1 General specifications

MODEL RATING (kVA)		400	500
Mechanical Characteristics			
Dimensions (WxHxD)	mm	1650 x 1994 x 850	
Dimensions with elevation kit (WxHxD)	mm	1650 x 2094 x 850	
Weight	kg	950	1000
Colour		Black (RAL 9005)	
Batteries		Fitted in external enclosure	
Input and output power cable entry		Bottom	
Exhaust cooling air		Top	



MODEL RATING (kVA)		400	500
Mechanical Characteristics (with TCE cabinet)			
Dimensions (WxHxD)	mm	1650 x 1994 x 850	
Dimensions with elevation kit (WxHxD)	mm	1650 x 2094 x 850	
Weight with TCE basic	kg	950+115	1000+115
Weight with TCE single input feed + cables	kg	950+245	1000+245
Weight with TCE dual input feed + cables	kg	950+285	1000+285
Colour		Black (RAL 9005)	
Batteries		Fitted in external enclosure	
Input power cable entry		Top	
Output power cable entry		Bottom	
Exhaust cooling air		None	



System Characteristics					
Topology		On-line, double conversion, Voltage and Frequency Independent (VFI)			
Technology		Second generation transformerless design			
Parallel configuration expansion		For added redundancy and/or capacity a parallel system can be extended to up to 10 modules on request			
Double conversion AC/AC efficiency with fully charged battery and linear load (PF = 1)	N%	25%load	50% load	75% load	100% load
		95.2%	96.0%	95.8%	95.6%

MODEL RATING (kVA)		400 kW		500	
Input Characteristics					
Input voltage	V	3x 380/220V+N, 3x 400/230V+N, 3x 415/240V+N			
Input voltage tolerance (ref to 3x400/230V) for Loads in %:	V	(-10% to +15%) 3x308/177 V to 3x460/264 V for <100% load (-20% to +15%) 3x280/161 V to 3x460/264 V for < 80% load (-30% to +15%) 3x240/138 V to 3x460/264 V for < 60% load			
Input frequency	Hz	35-70			
Input Overvoltage Category		II (2500Vpk) III (4000Vpk) with external SPD			
Backfeed		Optional			
Max. Input Power with rated output power and charged battery (pf=1.0)	KW	426		532	
Max. Input Current with rated output power and charged battery (pf=1.0)	A	617		771	
Max. Input Power with rated output power and discharged battery (pf=1.0)	KW	468		585	
Max. Input Current with rated output power and discharged battery (pf=1.0)	A	679		848	
		25%load	50% load	75% load	100% load
Input power factor (leading)	PF	0.96	0.985	0.99	0.99
Input current distortion (THDi) (%)	THD	9.0%	6.0%	4.5%	3.5%

MODEL RATING (kVA)		400 kW		500	
Battery Characteristics					
Variable number of 12V battery blocks (only even numbers allowed)	No:	44/50			
Max. battery charger current	A	60		100	
Battery type		Maintenance-free VRLA, NiCd, Li-Ion			
Temperature controlled charger		Yes (temperature sensor optional)			
Battery charging curve		Ripple-free: IU (DIN 41773)			
Battery test		Automatic and periodic (adjustable)			

MODEL RATING (kVA)		400 kW		500	
Output Characteristics					
Output rated power (@min 44 batt blocks)	KW	400		500	
Output current (PF=1.0) (@min 44 batt blocks)	A	577		722	
Output rated voltage	V	3x 380/220 or 3x 400/230 or 3x 415/250			
Output voltage stability (Static)	%	< ± 1.0			
Output voltage stability (Dynamic)	%	< ±4 (with load step 0-100%, 100-0%)			
Output voltage distortion with linear load	%	< 2 with linear load			
Output voltage distortion with non-linear load	%	< 4 (EN 62040-3:2001)			
Output frequency	Hz	50 or 60			
Output frequency tolerance	%	±0.1 free-running, quartz oscillator ±2 or ±4 with mains synchronised (selectable)			
Frequency slew rate	Hz/s	1.0			
Output waveform		Sine-wave with 0deg. phase imbalance @100% unbalanced load			
Permissible unbalanced load	%	100% (all 3 phases independently regulated)			

MODEL RATING (kVA)		400 kW	500
Overload capability on inverter	%	At PF=1.0 110% load for 10 minutes At PF=1.0 135% load for 1 minute At PF=0.9 125% load for 10 minutes At PF=0.9 150% load for 1 minute	
Inverter short circuit capability	A	2.0x In for 40ms	
Bypass short circuit capability		10x rated In for 10ms	
Crest factor		3:1	
Bypass operation		At ±15.0% of nominal input voltage	

Derated power with lower battery blocks											
Battery Blocks	30	32	34	36	38	40	42	44	46	48	50
400/500 kW UPS nominal power	65%	69%	74%	78%	82%	87%	91%	100%	100%	100%	100%

MODEL RATING (kVA)		400 kW	500
Environmental Characteristics			
Audible noise @ 100/50% load	dBA	78.5 / 73.6 (noise reduction kit available)	
Ambient temperature for UPS	°C	0-40	
Ambient temperature for batteries	°C	20°C recommended for optimum battery life	
Battery storage time at ambient temperature		Maximum 6 months	
Fan assisted cooling air flow		Front entry, top exit	
Airflow (25 - 30°C) with 100% non-linear load	m³/h	6550	
Heat dissipation with 100% non-linear load	W	24000	30000
Heat dissipation with 100% non-linear load	BTU/h	81913	102389
Heat dissipation without load	W	4000	
Relative air-humidity		Maximum 95% (non-condensing)	
Altitude Ratings (all models)			
Max altitude above sea level without de rating		1000m (3300ft) without de rating	
De-rating factor for use at altitudes above 1000m sea level according (IEC 62040-3)	Height above sea level (m/ft)		De rating factor for power
	1500 / 4850		0.95
	2000 / 6600		0.91
	2500 / 8250		0.86
		3000 / 9900	0.82
Standards (all models)			
Safety		EN62040-1-1 EN60950-1:2001/A11	
Electromagnetic compatibility		IEC/EN 62040-2, IEC/EN61000-3-2, IEC/EN61000-6-2	
Performance		EN 62040-3	
Product certification		CE UKCA	
Degree of protections		IP20	

Communication options (all models)		
Power Management Display (PMD)		LCD display and mimic diagram showing UPS operational status (Optional 7" TFT touch screen display)
Customer Interfaces: (Dry Ports)		Volt-free output interface provide status and alarm outputs for remote indication and interfacing with BMS systems. Together with customer inputs interface for connecting an Emergency Stop, On Generator status etc.
RS232 on Sub-D9 port / RS232 on USB port		For monitoring and integration in network management
RS485 on RJ45 port		Remote monitoring system with graphical display (option)
RS485 on RJ45 port		For multidrop purposes (option)
Slot for SNMP Card		Ethernet card for monitoring and integration in network management (option)
Slot for SNMP Card		Modem card for GSM remote monitoring (option)
Customer Interfaces: (Dry Ports)		LCD display and mimic diagram showing UPS operational status (Optional 7" TFT touch-screen display standard on 400/500kVA model)