



REHLKO *PW* 5000/TP

Three-phase uninterruptible power supply

(10–50 kVA)

Parallelable up to 400 kVA / 360 kW

User Manual

Document Control	1
Useful Contacts	1
1: Safety	1
1.1 Description of symbols used in this manual	1
1.2 User precautions	1
2: General Description	2
2.1 Reliability and Quality Standards	2
2.2 Rehlko PW 5000/TP Model Range	2
2.2.1 Single/Multi-cabinet configurations	3
2.3 Advanced Design Features	3
2.3.1 Input booster technology	3
2.3.2 Flexible battery management	3
2.3.3 Decentralized Parallel Architecture (DPA)	3
2.4 Warranty	4
2.5 Extended Warranty	4
2.6 Additional Service/Maintenance Support	5
3: Installation	6
3.1 Introduction	6
3.2 Receipt of the UPS	6
3.2.1 Site transportation	6
3.2.2 Unpacking the UPS	7
3.2.3 Batteries	7
3.3 Storage	8
3.3.1 UPS storage	8
3.3.2 Battery	8
3.4 Positioning	8
3.4.1 Planning the installation	8
3.5 UPS Power Cabling	10
3.5.1 General requirements (preparation and planning)	10
3.6 Connecting the UPS input supply	18
3.6.1 Safety notes	18
3.6.2 Preparation for the input cabling	18
3.6.3 Connecting the UPS input power cables	18
3.7 Connecting the UPS output	19
3.7.1 Safety notes	19
3.7.2 Preparation for the output cabling	19
3.7.3 Connecting the UPS output cables	20
3.8 Battery connections	24
3.8.1 Remote battery enclosures	24
3.8.2 Connecting the external battery enclosure	24
3.9 Multi-module control cabling and configuration	26
3.9.1 Connecting the parallel communication cables (Bus-lines)	26
3.10 Module interfacing facilities	27
3.10.1 JD1 Smart Port – Serial RS 232 and USB Port	27
3.10.2 X1 Dry Port (volt-free contacts)	28
3.10.3 JR1 / RS485 INTERFACE FOR MULTIDROP	28
3.10.4 X2 Dry Port – Optional Output Interfaces Terminal Block (X2)	29
4: Operation	30
4.1 Commissioning	30
4.2 Control Panel	30
4.2.1 Power Management Display (PMD)	30
4.2.2 Mimic LED indicators	31
4.2.3 Operator keys	31
4.3 Description of the LCD display	32
4.3.1 Status screens	32

4.3.2	Main menu screen	33
4.3.3	Event log menu screen	33
4.3.4	Measurements menu screen	33
4.3.5	Commands menu screen	35
4.3.6	UPS Data menu screen	35
4.3.7	Set-up User menu screen	36
4.3.8	Set-Up Service menu screen	36
4.4	Operating Modes	37
4.4.1	On-Line (Inverter) mode	37
4.4.2	Bypass (Line-Interactive) mode	37
4.4.3	Maintenance Bypass Mode	38
4.4.4	Multi-module configuration concept	39
4.5	Operating Instructions	40
4.5.1	Transfer to Maintenance Bypass Mode	40
4.5.2	Starting the UPS system from the Maintenance Bypass	42
4.5.3	Complete system shutdown	44
4.5.4	Individual module start/stop procedure	45
5:		47
5.1	Maintenance	47
5.2	Introduction	47
5.3	System calibration	47
5.4	User responsibilities	47
5.5	Routine maintenance	47
5.6	Battery Testing	48
6: Troubleshooting		49
6.1	Alarms	49
6.2	Menu, Commands, Event Log, Measurements,	50
6.2.1	Event Log Screen	50
6.2.2	Fault Identification and Rectification Messages and Alarms	50
6.3	Contacting Service	51
7: Options		52
7.1	Introduction	52
7.2	Remote Emergency Stop facilities	52
7.3	Generator ON facilities	53
7.4	Temperature sensor for temperature-dependent battery charging	54
7.5	UPS Monitoring and automated control software	55
7.5.1	The importance of UPS management	55
7.5.2	SNMP monitoring software	55
7.5.3	WAVEMON UPS monitoring and control software	55
7.5.4	PowerREPORTER™ management software	56
8: Specifications		58
8.1	Mechanical	58
8.2	Input Characteristics	59
8.3	Output Characteristics	59
8.4	Battery Characteristics	60
8.5	Environmental	60
8.6	Heat Dissipation With Non-Linear Loads	61
8.7	Standards	61
8.8	Communication Options	61
8.9	Fuses & Cables Quick Reference	62

1. Safety

1.1 Description of symbols used in this manual



WARNING: The warning symbol is used where there is danger of an electrical shock, equipment damage or personal-injury.



CAUTION: The caution symbol is used to highlight important information to avoid possible equipment malfunction or damage.

1.2 User precautions



WARNING: Keep this manual with the UPS for future reference.



WARNING: The UPS and peripheral equipment must be installed and commissioned by suitably qualified and trained personnel who are aware of the potential shock hazards.



WARNING: Do not attempt to install this UPS system until you are satisfied that ALL the safety instructions and hazard warnings contained in this manual are read and fully understood.



WARNING: High leakage current!
Ensure that the UPS has been correctly earthed before you connect the mains power supply!



WARNING: This UPS must not be started-up or put into use without having first been commissioned by a fully trained engineer authorised by the manufacturer.



WARNING: All servicing must be performed by qualified personnel. Do not attempt to service the UPS yourself. You run risk of exposure to dangerous voltages by opening or removing the UPS-covers! Rehiko will assume no responsibility nor liability due to incorrect operation or manipulation of the UPS.



WARNING: The Rehiko PW 5000/TP is a Class A UPS product (according to BS EN 62040-2:2006). In a domestic environment the UPS may cause radio interference. In such an environment the user may be required to undertake additional measures.

2. General Description

2.1 Reliability and Quality Standards

Congratulations on your purchase of the Rehiko PW 5000/TP UPS.

The Rehiko PW 5000/TP UPS represents a completely new generation of mid-range, 3 phase UPS-Systems, incorporating the latest technological developments in power engineering. It is an advanced double conversion UPS, VFI (Voltage and Frequency Independent) topology that responds fully to both highest availability and environmentally friendly requirements compliant with IEC 62040-3 (VFI-SS-111) standards. High reliability, upgrade ability, low operating costs and excellent electrical performance are only some of the highlights of this innovative UPS solution.

Rehiko specialises in the design, building, installation and maintenance of Uninterruptible Power Systems. This compact and powerful UPS is just one example of our wide range of state-of-the-art power protection devices and will provide your critical equipment with a steady and reliable power supply for many years.

The criteria and methods which are used in the manufacture and maintenance of UPS systems are certified to International Standard ISO 9001/EN 29001 and ISO 14001. A full UPS Specification is given in Chapter 8 this manual.

2.2 Rehiko PW 5000/TP Model Range

The Rehiko PW 5000/TP UPS range covers 10, 15, 20, 25, 30, 40 and 50kVA models, in three different sized cabinets, that can be employed in a Single or Multi-Module configuration.



Figure 2.1 Rehiko PW 5000/TP Cabinet details

2.2.1 Single/Multi-cabinet configurations

The Rehiko PW 5000/TP UPS may be configured to operate as a single cabinet or several (up to 20) cabinets can be connected in parallel to operate as a multi-module UPS system. A multi-module configuration is selected either to increase the system's total power capacity or to provide module redundancy. This manual describes the installation, configuration and operation of both single and multi-module systems.

Note: Although the UPS single/multi configuration can be modified in the field it is generally specified on ordering so that the module can be configured and fully tested in the factory prior to despatch.

2.3 Advanced Design Features

2.3.1 Input booster technology

The UPS module's inbuilt advanced booster technology results in a perfect sinusoidal input power quality at 0.99 input power factor with a harmonic content of 3% THD(i). This leads to a more reliable total system operation and savings in generator and transformer sizing, as losses in the windings are minimised. It also means that traditional harmonic filters are no longer required.

The high power factor presented by the UPS on the incoming mains supply minimises cabling and fusing costs due to the resulting lack of reactive power consumption. This, together with the accompanying low harmonic currents, provide the following benefits:

- No additional losses in wires and cables.
- No extra heating of transformers and generators.
- No over sizing of generators.
- No false circuit breaker tripping and malfunction.
- No erratic operation of computers, telecommunication, monitors, electronic test equipment etc.
- No resonance with power factor correction capacitors.

2.3.2 Flexible battery management

This equipment employs a flexible battery management which avoids premature deterioration of battery life by advanced management of battery charging and preventive failure diagnostics.

The major benefits are:

- AC-ripple free battery charging due to a dc-dc charger separated from the rectifier and inverter.
- Wide range of number of battery blocks (22-50 blocks of 12V; depending on autonomy times).
- Wide UPS input voltage operating window extends the battery life due to fewer discharge cycles.
- Battery discharge protection caused by load jumps.
- Proactive battery protection from false manipulations and inadequate charging voltages.
- Proactive battery failure detection thanks to Advanced Battery Diagnosis (ABD) - Algorithm.
- User selectable battery tests.
- Optional temperature compensated charging to enhance battery life.

2.3.3 Decentralized Parallel Architecture (DPA)

The Rehiko PW 5000/TP system features DPA paralleling technology that provides n+x redundancy without introducing a single-point-of-failure. The modules utilizing the DPA technology are completely autonomous by means of individual power units, bypasses, CPUs, control panels and separate battery configuration.

2.4 Warranty

The Rehiko PW 5000/TP UPS is supplied with a limited warranty that the UPS and its component parts are free from defects in materials and workmanship for a period of one year from the date of original commissioning, or fifteen months from the date of original delivery, whichever is the sooner. This warranty is the only warranty given and no other warranty, express or implied, is provided.

This warranty is invalidated if the UPS is used without having first been commissioned by a fully trained and authorised person. This warranty does not apply to any losses or damages caused by misuse, abuse, negligence, neglect, unauthorised repair or modification, incorrect installation, inappropriate environment, accident, act of God or inappropriate application.

If the UPS fails to conform to the above within the warranty period then Rehiko will, at its sole option, repair or replace the UPS. All repaired or replaced parts will remain the property of Rehiko.

As a general policy, Rehiko does not recommend the use of any of its products in life support applications where failure or malfunction of the product can be reasonably expected to cause failure of the life support device or to significantly affect its safety or effectiveness. Rehiko does not recommend the use of any of its products in direct patient care. Rehiko will not knowingly sell its products for use in such applications unless it receives in writing assurances satisfactory to Rehiko that the risks of injury or damage have been minimized, the customer assumes all such risks and the liability of Rehiko is adequately protected under the circumstances.



CAUTION: *The UPS system may contain batteries which must be re-charged for a minimum of 24 hours every six months to prevent deep-discharging. Batteries that have been, for whatever reason, deeply-discharged are not covered by the warranty.*

2.5 Extended Warranty

The Standard Warranty may be enhanced by protecting the UPS with an Extended Warranty Agreement (maintenance contract). An Extended Warranty Agreement enhances the standard warranty by providing:

- Regular preventative maintenance inspections
- Guaranteed speed of response to operational problems
- 24 hour telephone support
- Fully comprehensive (excluding batteries) cover

2.6 Additional Service/Maintenance Support

If you are interested in obtaining an extended warranty for your Rehiko PW 5000/TP, or require service/maintenance support for any other UPS you may have, please contact Rehiko at the following address:

UK

www.ups.rehiko.co.uk

ukservice.ups@rehiko.com

uktechnicalsupport.ups@rehiko.com

uksales.ups@rehiko.com

ukservicesales.ups@rehiko.com

Rehiko web site

Service department – booking service, fault reporting etc.

Technical queries

Hardware sales

Extended warranty agreements etc

IRELAND

www.ups.rehiko.ie

ieinfo.ups@rehiko.com

Rehiko web site

Service department, technical queries, hardware sales and extended warranty agreements

SINGAPORE

www.ups.rehiko.sg

salesups.sg@rehiko.com

serviceups.sg@rehiko.com

Rehiko web site

Hardware sales

Contract customer support, maintenance contracts renewals

3. Installation

3.1 Introduction

This chapter contains all the information necessary for the correct unpacking, positioning, cabling and installation of the Rehiko PW 5000/TP UPS.



WARNING: All the operations described in this section must be supervised by an authorised electricians or suitably qualified person.

WARNING: Rehiko will take no responsibility for any personal or material damage caused by incorrect cabling or operations, or activities which are not carried out in strict accordance with the instructions contained in this manual.

3.2 Receipt of the UPS

The UPS and accessories are delivered on a specifically designed pallet that is easy to move with a forklift or a pallet jack.



CAUTION: When off loading the UPS always keep it in an upright position.

Do not drop the equipment.

Do not stack the pallets due to the high-energy batteries involved and the heavy weight.

The packing container protects the UPS from mechanical and environmental damage. This protection is further increased by wrapping the Rehiko PW 5000/TP UPS with a plastic sheet.

Upon receiving the UPS, carefully examine the packing container and the UPS for any sign of physical damage. The outside 'Tip&Tel' ("FRAGILE" and "ARROW") indicator should be intact if the equipment has been transported in an upright position. In case of rupture (or if they are suspect) inform the carrier and Rehiko immediately.



CAUTION: Visible transport damages must be notified to the carrier immediately after receipt!

Other claims for shipping damage must also be filed immediately and the carrier must be informed within 7 days of receipt of the equipment.

Packing materials should be stored for further investigation.

Ensure that the received UPS corresponds to the description indicated in the delivery note.

3.2.1 Site transportation

If you transport the UPS equipment after it has been off-loaded (for example, for storage or moving to a different installation location) please observe the following precautions.



CAUTION: Potential dangers:

Do not tilt the UPS or Battery Cabinet by more than 10° as it might damage the equipment. If the equipment has been tilted do not connect it to the mains electricity supply.

The weight of the UPS system could cause serious injuries to personnel or other equipment in the surrounding area.



CAUTION: Storage:

The UPS should be stored in the original packing and shipping carton.

The recommended storing temperature for the UPS system and batteries is between +5°C and +40°C.

The UPS system and the battery sets must be protected from humidity < 90% RH (non-condensing).

3.2.2 Unpacking the UPS



WARNING: The UPS system, the battery cabinet (option) and the batteries are heavy and may tip during transportation causing serious injury if the unpacking instructions are not followed closely.

The cabinets are attached to a shipping pallet, wrapped in polythene and protected by a sturdy cardboard covering.



CAUTION: Before you finally unpack the equipment, remove any additional external shipping packaging and visually check that the 'Tip&Tel' indicator ("FRAGILE" and "ARROW") on the packing container is intact.

1. Ensure that the floor surface is level and suitable for wheeling and taking the heavy weight.
2. Remove cardboard packing container by pulling it upwards. The packaging will contain a wooden ramp.
3. Remove the protective plastic cover and any other packing around the UPS.
4. Remove the fixings securing the UPS to the pallet.
5. Position the enclosed ramp ('A' & 'B' cabinets) at the rear side of the cabinet and roll the UPS down the ramp.
6. Retain the packaging materials for future shipment of the UPS.
7. Examine the UPS for any sign of damage and notify your carrier or supplier immediately if damage is apparent.



Figure 3.1 Unpacking cabinets A & B

Checking the nameplate

Before proceeding, check that the technical specifications on the nameplate, situated on the rear of the UPS or behind the front internal door, corresponds to the purchased material mentioned in the goods delivery note.

3.2.3 Batteries

The batteries connected to the UPS are usually of a sealed, maintenance-free design. The batteries can be mounted either within the UPS, in an external battery cabinet, or on a bespoke battery rack, depending on the required autonomy time and paralleling arrangement. For optimum reliability a separate battery string should be connected to each individual UPS. The batteries are usually shipped separately and fitted by a manufacturer-approved engineer when the UPS is commissioned.

If the UPS is delivered without batteries, Rehiko is not responsible for any damage or malfunctioning caused to the UPS by the incorrect supply, storage, installation or connection of batteries by third parties.

3.3 Storage

3.3.1 UPS storage

If you plan to store the UPS prior to use, it should be kept in a clean, dry environment with an ambient temperature between -25°C to $+70^{\circ}\text{C}$ and relative humidity of less than 90%.

If the UPS is removed from the packing container you must also ensure you protect it from dust.

3.3.2 Battery

The storage capability of the UPS batteries depends greatly on the ambient temperature. It is important not to store the UPS batteries for longer than 6 months at 20°C , 3 months at 30°C or 2 months at 35°C storage temperature without recharging the battery.

For longer term storage the battery must be fully recharged every 6 months @ 20°C .



CAUTION: Sealed batteries must never be stored in a discharged or partially discharged state. Extreme temperature, under-charge, overcharge or over-discharge will destroy the batteries!



Key Point: Note the following:

- Charge the battery both before and after storing.
- Always store the batteries in a dry, clean, cool environment in their original packaging.
- If the packaging is removed protect the batteries from dust and humidity.

3.4 Positioning

3.4.1 Planning the installation

A certain amount of pre-planning will help ensure smooth, trouble-free equipment installation. The following *guidelines* should be taken into account when planning a suitable UPS location and environment.

1. The equipment must be installed and transported in a upright position.
2. The floor at the installed location and en-route from the off-loading point must be able to safely take the weight of the UPS and battery equipment plus fork lift during transit. The floor material where the UPS is to be located should be non-flammable.
3. The UPS cabinet requires space to bottom/front and back to enable cooling airflow. Allow a minimum of 200mm clearance at the back of the cabinet. Suitable ventilation airflow (not exceeding $+40^{\circ}\text{C}$) must be provided (see *Figure 3.2*).
4. All parts of the UPS requiring access for maintenance, servicing and user operation are accessible from the front and rear. Reserve a minimum of 900mm space at the front of the UPS cabinet.
5. A temperature of 20°C is recommended to achieve a long battery life.
6. Avoid high ambient temperature, moisture and humidity.

In summary

The UPS should be located where:

- a) Humidity ($< 90\%$ non-condensing) and temperature ($+15^{\circ}\text{C}$ / $+25^{\circ}\text{C}$) are within prescribed limits.
- b) Fire protection standards are respected.
- c) Cabling can be performed easily.
- d) A minimum 900mm front accessibility is available for service or periodic maintenance.
- e) Requested air cooling flow is available.
- f) The air conditioning system can provide a sufficient amount of air cooling to keep the room at, or below, the maximum desired temperature.
- g) No dust or corrosive/explosive gases are present.
- h) The location is vibration free.
- i) If the UPS is to be installed in bayed enclosures, partition walls have to be installed.

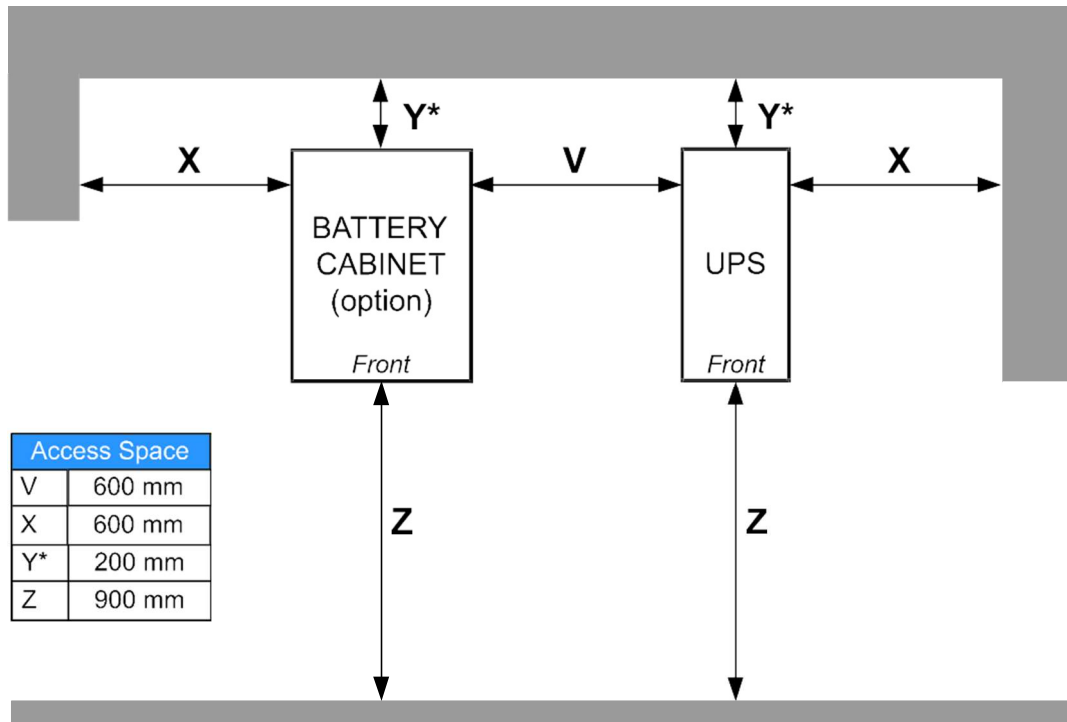

*Although the diagram shows 200mm is required at the rear of the cabinet, 'A' and 'B' cabinets should be cabled such that the cabinet can be pulled forward to give access to the rear connections.

Figure 3.2 UPS Space Recommendations

		10kVA	15kVA	20kVA	25kVA	30kVA	40kVA	50kVA
Heat Dissipation with 100% Non-linear Load per range (EN 62040-3)	W	600	900	1100	1400	1700	2300	2900
Heat Dissipation with 100% Non-linear Load per range (EN 62040-3)	BTU/h	2048	3072	3754	4778	5802	7850	9898
Airflow (25°C - 30°C) with 100% Non-linear Load per range (EN 62040-3)	m ³ /h	150	150	150	150	570	570	570
Heat Dissipation without load	W	120	150	150	170	250	300	350

	Cabinet A	Cabinet B	Cabinet C	Batt Cab C
Dimensions (WxHxD)mm	345x720x710	345x1045x710	440x1420x910	480x1420x940
Maintenance/Service Accessibility	Top, rear, front, left and right side		Top, front, left and right side	
Positioning	Min. 200mm rear space required for ventilation			
Input and Output Power Cabling	From the bottom at the rear.		From the bottom at the front	

3.5 UPS Power Cabling

3.5.1 General requirements (preparation and planning)

It is the customer's responsibility to provide all external fuses, isolators and cables used to connect the UPS input and output power supplies. The information in this section should help in the planning and preparation of the UPS power cabling.

The UPS input supply and bypass supply should be connected to the utility mains through a LV-Distribution board and protected by a circuit breaker or fuse. This provides overload protection and also a means of isolating the UPS from the mains supply when required. Similarly, the UPS output supply should be connected to the load equipment via a suitably fused output distribution panel.

The UPS can be wired with a 'single feed' input (standard), whereby the UPS input supply is internally connected to the UPS bypass circuit, or it can be wired with a 'dual feed' input – where the UPS bypass circuit is connected to a dedicated 'bypass' supply (see Figure 3.4).

Figure 3.4 identifies the UPS input/output cabling requirements and provides information regarding the necessary fuse and cable ratings, and cable sizing.



Key Point: This information is given for guidance only. All fuses, isolators and power cables must be rated and installed in accordance with the prescribed IEC standards or local regulation – e.g. BS7671.

Figures 3.6 and 3.7 show details of the power terminal connections within the UPS including connection sizes and recommended tightening torque. This illustration shows that the UPS unit requires the following power cables:

Rectifier (In):

- three-phase (1L1, 1L2, 1L3)
- neutral (1N)
- protective earth (PE) connection for the rectifier input

Bypass (In) (Dual feed system only):

- three-phase (2L1, 2L2, 2L3)
- neutral (2N)
- protective earth (PE) connection for the bypass if used as 'Dual Feed' input

Load (Out):

- three-phase (3L1, 3L2, 3L3)
- neutral (3N)
- protective earth (PE) connection for the load output

External Battery:

- Plus (+)
- Common (N)
- Minus (-)
- protective earth (PE) connection for the external batteries
- the UPS internal batteries must be disconnected if external batteries are used. Under no circumstances should external and internal batteries be connected together in parallel.

Input neutral grounding



Key Point: Input neutral is required to operate the rectifier.

In TN - S systems, no 4 - pole input switches or circuit breakers should be used. During battery operation the neutral must always be grounded.

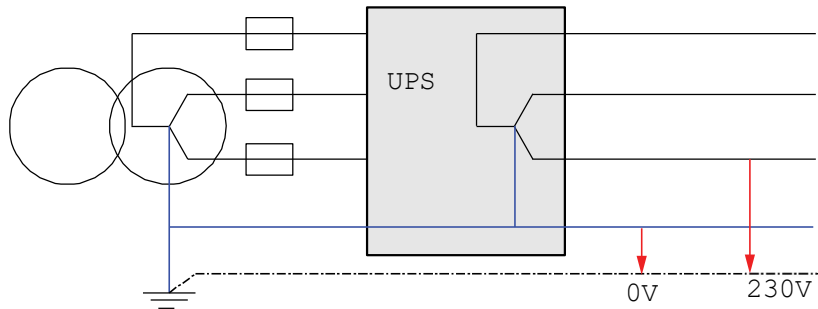

Figure 3.3 Input neutral grounding

External Backfeed protection

A UPS shall prevent hazardous voltage or hazardous energy from being present on the UPS input AC distribution after interruption of the input AC power. This is achieved by mandatory backfeed protection. Unless optional internal protection is included in UPS frame, such protection shall be provided by others and be installed as part of building installation. The backfeed protection shall be implemented in the form of an air gap, separating the upstream circuit from UPS when AC input fails. This is typically achieved through a contactor installed over the common AC input line or over each separate AC input line. Preferred location is just after the overcurrent protective devices serving each UPS input line. Such contactors shall have the coil supplied by the AC upstream circuit, to be engaged when AC upstream voltage is ON or dis-engaged when AC upstream voltage is OFF.

Specifications:

The device shall be three-poles, creating an air gap of at least 3 mm.

The thermal current shall meet the external overcurrent protection's rating described in the coming sections.

Electrical contractor is required to attach following "Voltage backfeed warning label" as close as possible to the external isolator:

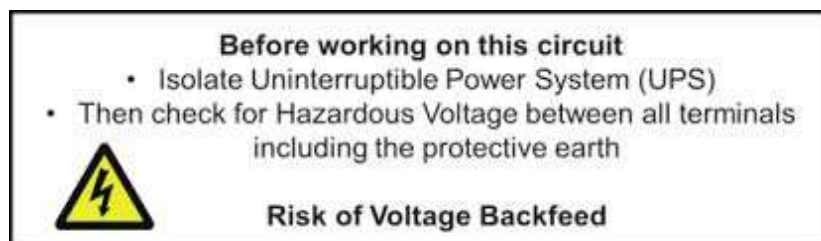

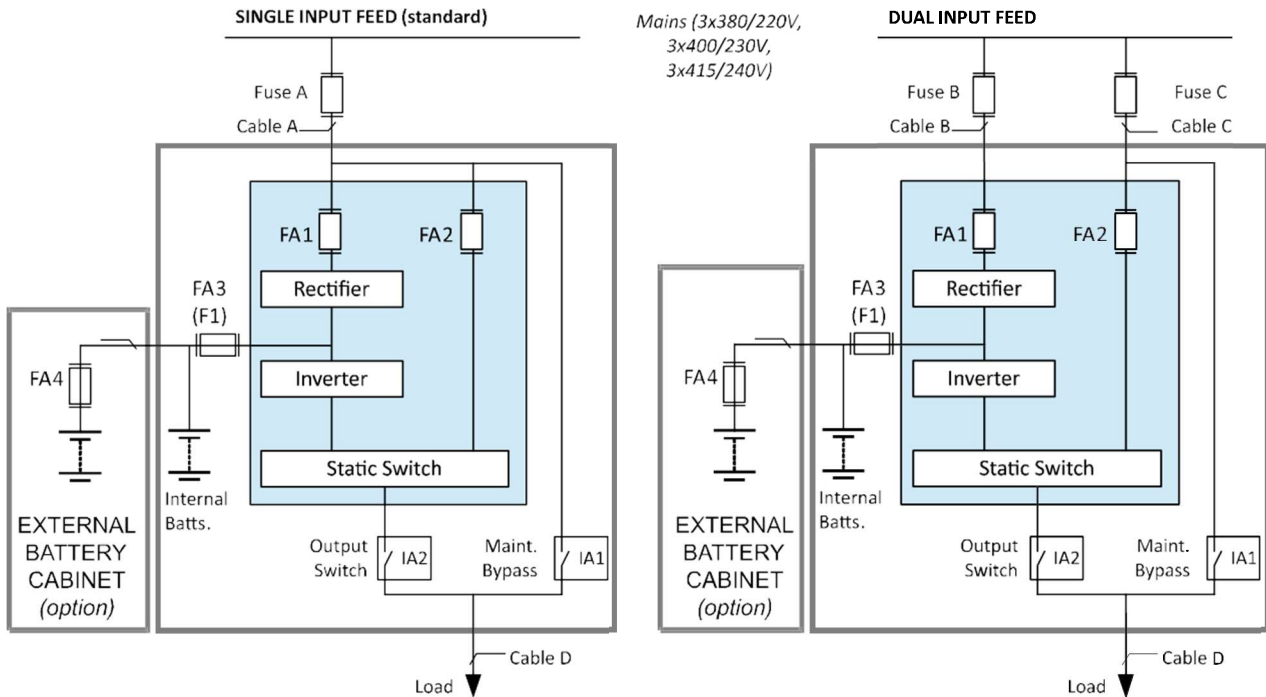

Mains (3x380/220V,
3x400/230V,
3x415/240V)

SINGLE INPUT FEED

Power (kVA)	Fuse A (Agl/CB) (A)	Cable A (mm ²)	Cable D (mm ²)
10	3 x 20	5 x 2.5	5 x 2.5
15	3 x 32	5 x 4.0	5 x 4.0
20	3 x 40	5 x 6.0	5 x 6.0
25	3 x 40	5 x 6.0	5 x 6.0
30	3 x 63	5 x 10	5 x 10
40	3 x 80	5 x 25	5 x 25
50	3 x 80	5 x 25	5 x 25

DUAL INPUT FEED

Power (kVA)	Fuse B (Agl/CB) (A)	Cable B (mm ²)	Fuse C (Agl/CB) (A)	Cable C (mm ²)	Cable D (mm ²)
10	3 x 20	5 x 2.5	3 x 20	5 x 2.5	5 x 2.5
15	3 x 32	5 x 4.0	3 x 32	5 x 4.0	5 x 4.0
20	3 x 40	5 x 6.0	3 x 40	5 x 6.0	5 x 6.0
25	3 x 40	5 x 6.0	3 x 40	5 x 6.0	5 x 6.0
30	3 x 63	5 x 10	3 x 63	5 x 10	5 x 10
40	3 x 80	5 x 25	3 x 80	5 x 25	5 x 25
50	3 x 80	5 x 25	3 x 80	5 x 25	5 x 25

Notes:

1. Fuse and Cable recommendations to IEC 60950-1:2001
2. The fuse and cable rating details in the above tables are a recommendation only.
3. The UPS must be installed to prescribed IEC or local regulations (e.g. BS7671).
4. External DC Cables and Battery fuses are bespoke to the installation.

Figure 3.4 Rehlko PW 5000/TP fuse & cable rating

Cabling a parallel system

In order to achieve equal load sharing between the UPS-cabinets in a multi-cabinet installation, the input cables from the input distribution board to each UPS cabinet should be of equal length. Similarly the UPS output cables to the output distribution board should be of equal length (see *Figure 3.5*).

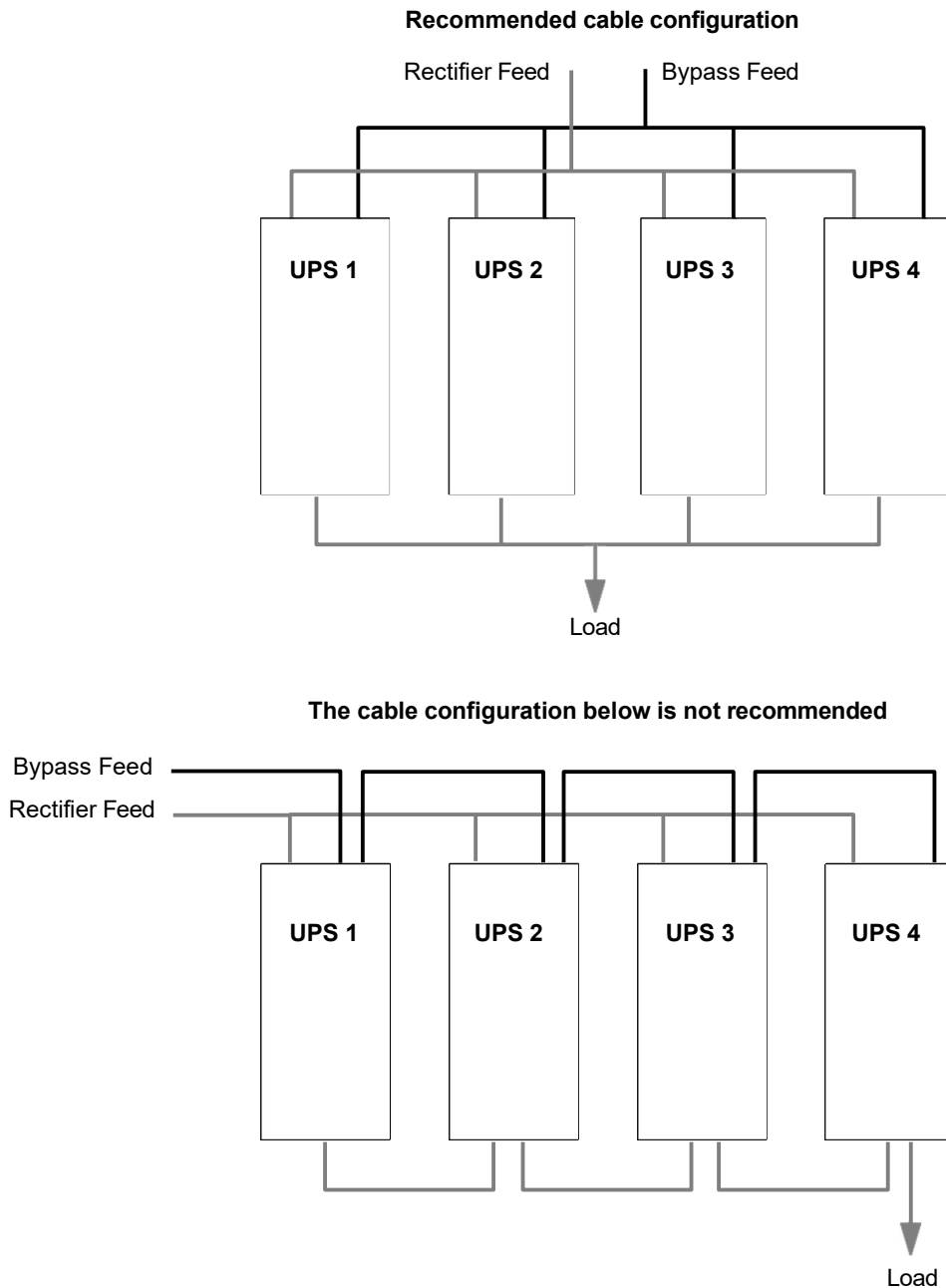

Figure 3.5 Cable lengths for multi cabinet configurations (assuming a dual input supply)

**10kVA – 25kVA (Cabinets A & B)
Power Connections (Single input feed)**

For models in this power range the external power connections are made to a

row of terminals located on the UPS Filter Board which is accessible from the rear of the UPS module.

Note that the Single Input configuration requires the bypass line fuses to be connected to FA7/FA9/FA11 on the Filter Board. This is the standard configuration

set when leaving the factory unless a dual input configuration is specified.

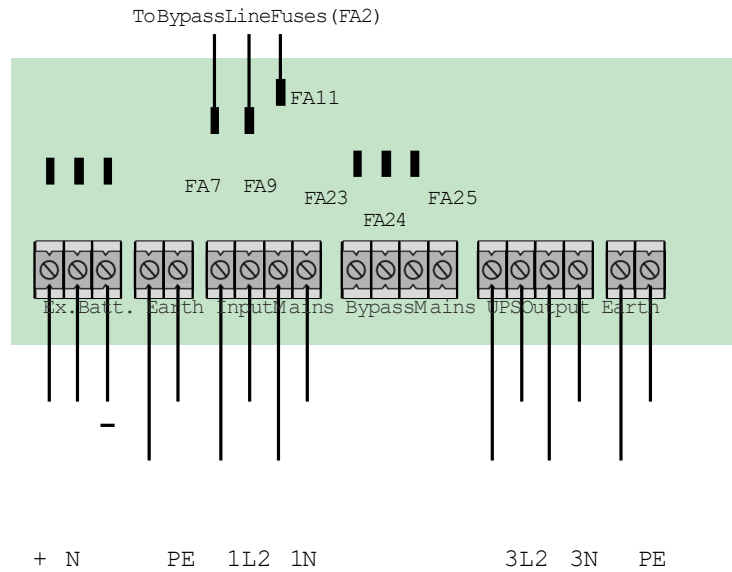

**10kVA – 25kVA (Cabinets A & B)
Power Connections (Dual input feed)**

This illustration shows the connections for

a Dual input configurations, with a separate mains supply connected to the

Bypass Mains terminals.

Note that the Dual Input configuration requires the bypass line fuses to be connected to FA23/FA24/FA25 on the Filter Board. If necessary these cables will be reconfigured by the Commissioning Engineer as part of the commissioning procedure.

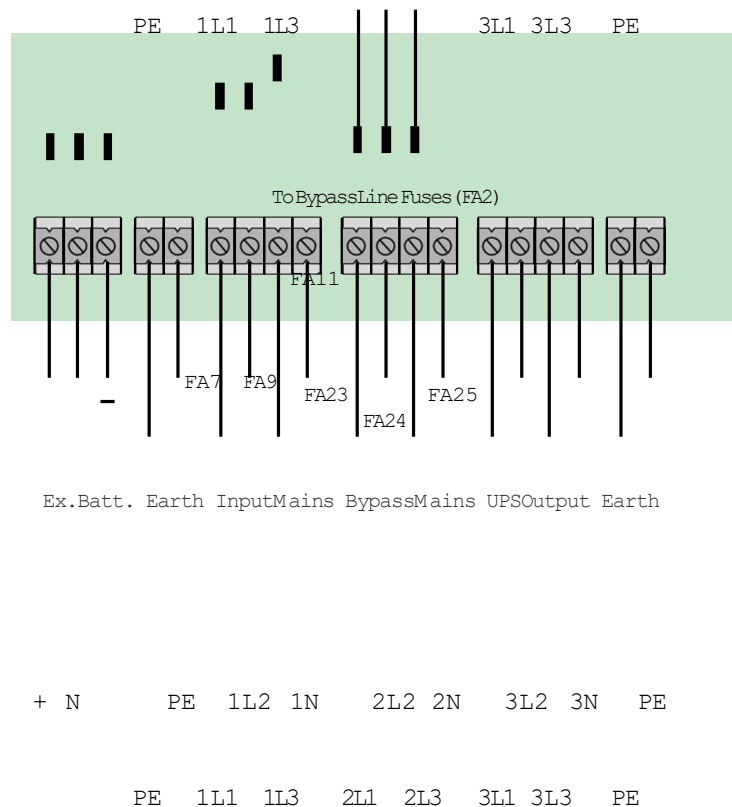

Terminal Connections	Battery (+ / N / -)	Input Bypass 2L1, 2L2, 2L3 +N	Input Rectifier 1L1, 1L2, 1L3 +N	Output load 3L1, 3L2, 3L3 +N	Tightening Torque
----------------------	---------------------	-------------------------------	----------------------------------	------------------------------	-------------------

Cabinets 'A' & 'B' (10-25kVA) (PE)	3 x 16 mm ² 1 x 16 mm	4 x 16 mm ² 1 x 16 mm ²	4 x 16 mm ² 1 x 16 mm ²	4 x 16 mm ² 1 x 16 mm ²	1.5 Nm 1.5 Nm
---------------------------------------	-------------------------------------	--	--	--	------------------

Notes:

1. Fuse and Cable recommendations to IEC 60950-1:2001
2. The fuse and cable rating details in the above tables are a recommendation only.
3. The UPS must be installed to prescribed IEC or local regulations (e.g. BS7671)

Figure 3.6 10-25kVA Connection details

**30kVA – 50kVA
(Cabinet C)
Power Connections
(Single input feed)**

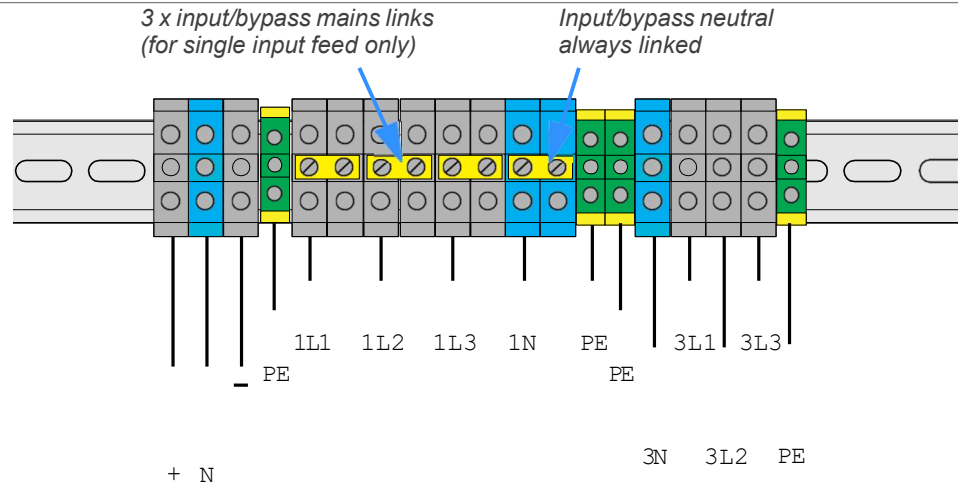

For models in this power range the external power connections are made to a row of terminals blocks mounted on a rail on the front of the UPS module.

Note that the Single Input configuration requires three links to be fitted between the input and bypass supply connections, as shown in the above illustration. This is the standard configuration set when leaving the factory unless a dual input configuration is specified.

**30kVA – 50kVA
(Cabinet C)
Power Connections
(Dual input feed)**

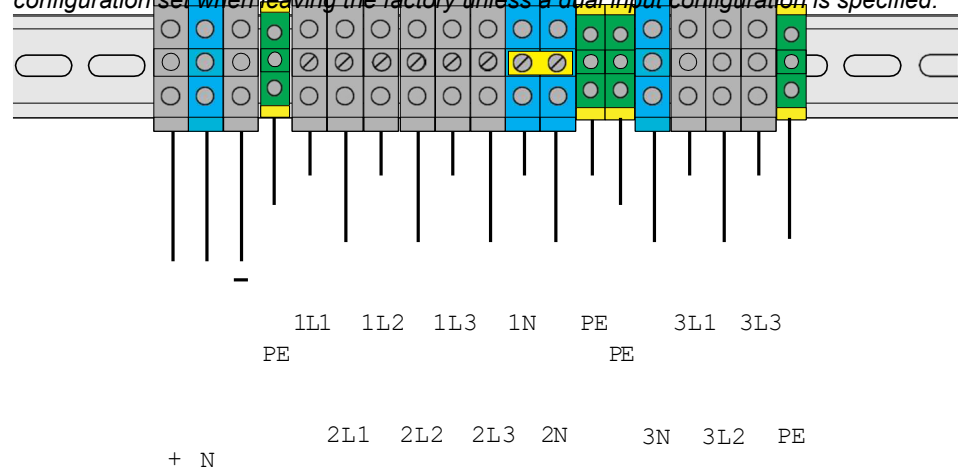

The above illustration shows the connections for a Dual input configurations, with a separate mains supply connected to the Bypass Mains terminals.

Note that the Dual Input configuration requires the links to be removed between in input and bypass terminals. If necessary these cables will be reconfigured by the Commissioning Engineer as part of the commissioning procedure.

Terminal Connections	Battery (+ / N / -)	Input Bypass 2L1, 2L2, 2L3 +N	Input Rectifier 1L1, 1L2, 1L3 +N	Output load 3L1, 3L2, 3L3 +N	Tightening Torque
Cabinet 'C' (25-30kVA) (PE)	3 x 35 mm2 1 x 16 mm2	4 x 16 mm2 1 x 16 mm2	4 x 16 mm2 1 x 16 mm2	4 x 16 mm2 1 x 16 mm2	3.5 Nm 1.5 Nm
Cabinet 'C' (40-50kVA) (PE)	3 x 35 mm2 1 x 35 mm2	4 x 35 mm2 1 x 35 mm2	4 x 35 mm2 1 x 35 mm2	4 x 35 mm2 1 x 35 mm2	3.5 Nm 3.5 Nm

Notes:

1. Fuse and Cable recommendations to IEC 60950-1:2001
2. The fuse and cable rating details in the above tables are a recommendation only.
3. The UPS must be installed to prescribed IEC or local regulations (e.g. BS7671)

Figure 3.7 30-50kVA Connection details

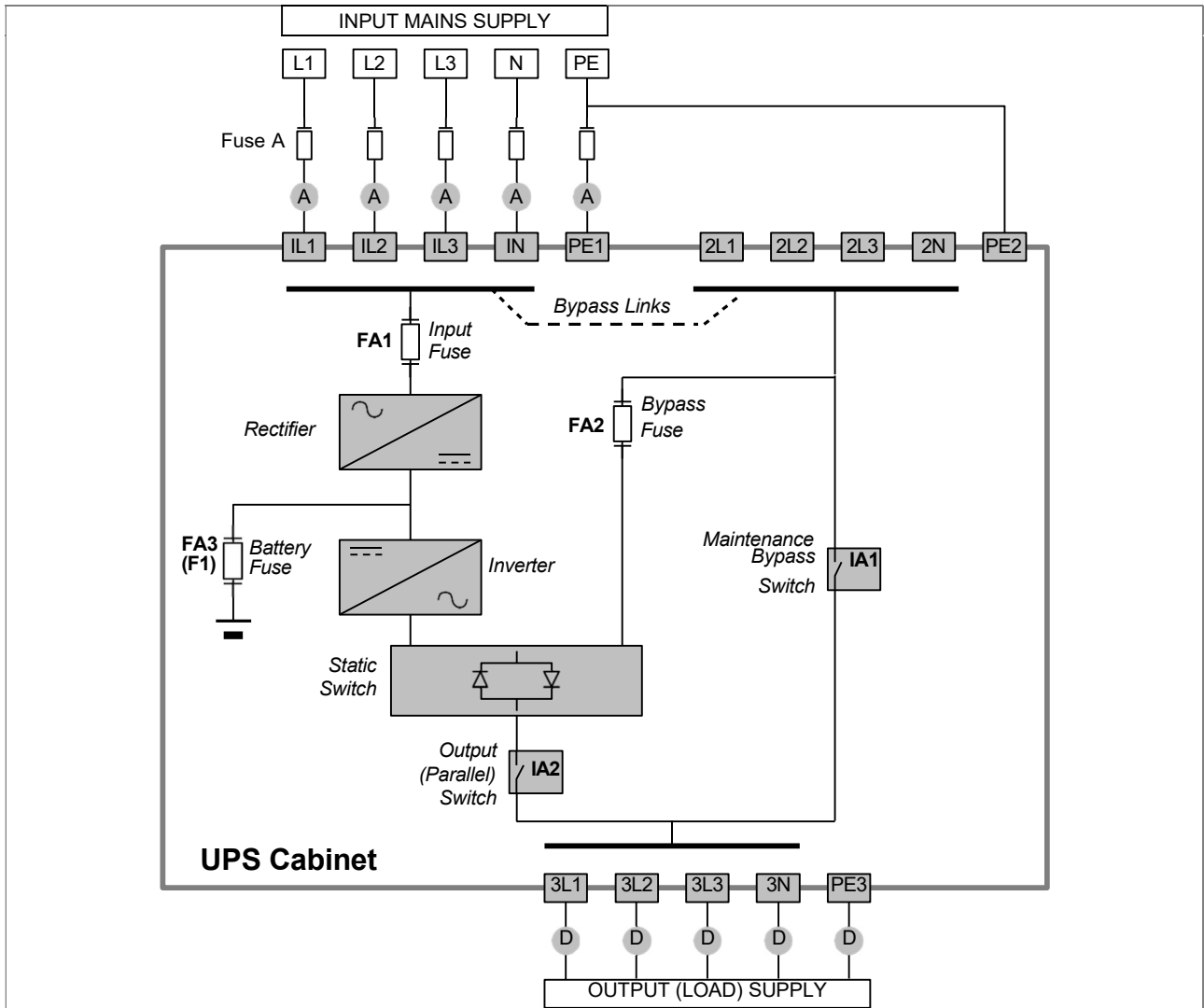

SINGLE INPUT FEED

Power (kVA)	Fuse A (Agl/CB) (A)	Cable A (mm ²)	Cable D (mm ²)
10	3 x 20	5 x 2.5	5 x 2.5
15	3 x 32	5 x 4.0	5 x 4.0
20	3 x 40	5 x 6.0	5 x 6.0
25	3 x 40	5 x 6.0	5 x 6.0
30	3 x 63	5 x 10	5 x 10
40	3 x 80	5 x 25	5 x 25
50	3 x 80	5 x 25	5 x 25

Notes:

1. Fuse and Cable recommendations to IEC 60950-1:2001
2. The fuse and cable rating details in the above tables are a recommendation only.
3. The UPS must be installed to prescribed IEC or local regulations (e.g. BS7671).
4. External DC Cables and Battery fuses are bespoke to the installation.

Figure 3.8 Single input feed - power connection diagram

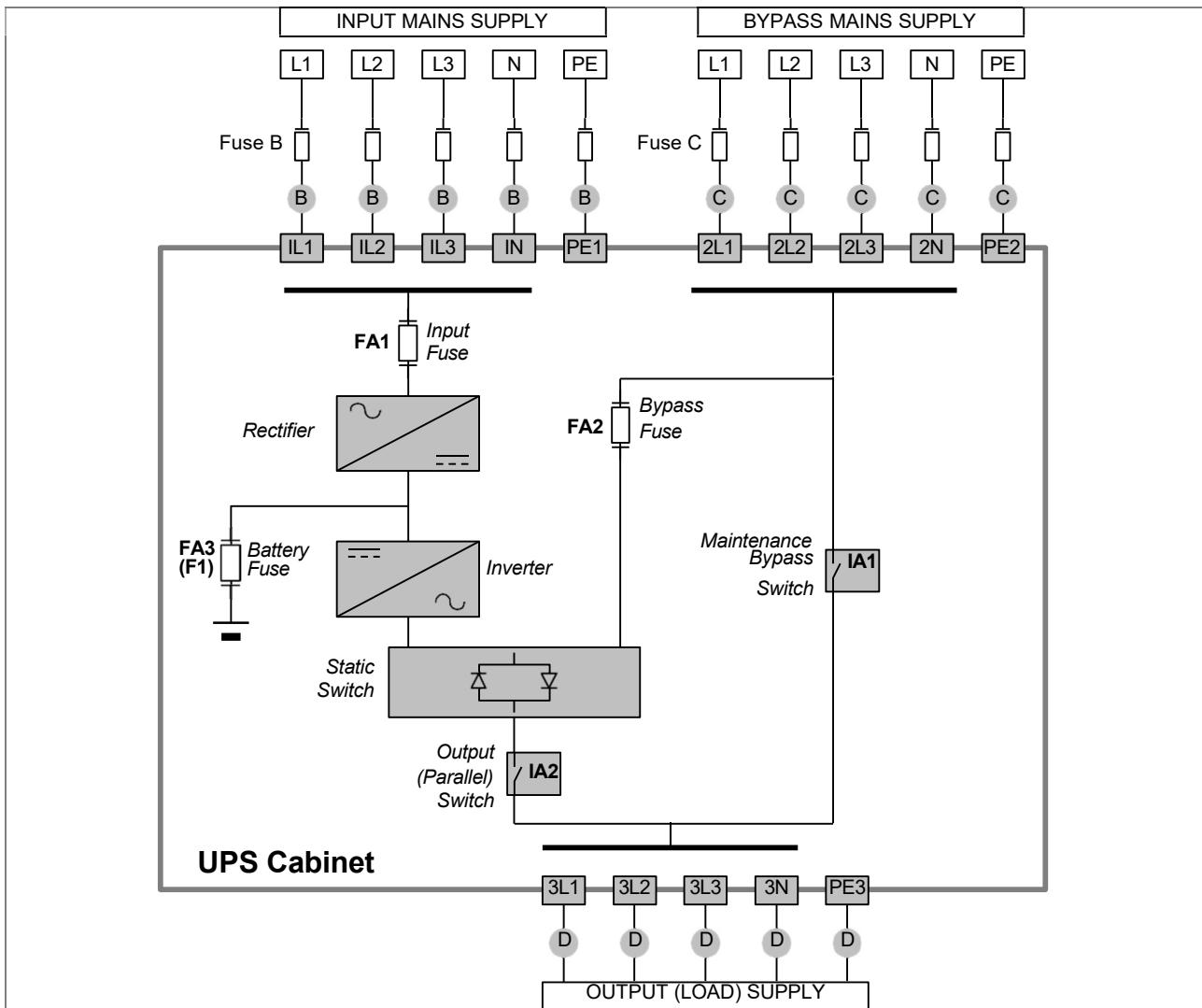

DUAL INPUT FEED

Power (kVA)	Fuse B (Agl/CB) (A)	Cable B (mm ²)	Fuse C (Agl/CB) (A)	Cable C (mm ²)	Cable D (mm ²)
10	3 x 20	5 x 2.5	3 x 20	5 x 2.5	5 x 2.5
15	3 x 32	5 x 4.0	3 x 32	5 x 4.0	5 x 4.0
20	3 x 40	5 x 6.0	3 x 40	5 x 6.0	5 x 6.0
25	3 x 40	5 x 6.0	3 x 40	5 x 6.0	5 x 6.0
30	3 x 63	5 x 10	3 x 63	5 x 10	5 x 10
40	3 x 80	5 x 25	3 x 80	5 x 25	5 x 25
50	3 x 80	5 x 25	3 x 80	5 x 25	5 x 25

Notes:

1. Fuse and Cable recommendations to IEC 60950-1:2001
2. The fuse and cable rating details in the above tables are a recommendation only.
3. The UPS must be installed to prescribed IEC or local regulations (e.g. BS7671).
4. External DC Cables and Battery fuses are bespoke to the installation.

Figure 3.9 Dual input feed - power connection diagram

3.6 Connecting the UPS input supply



WARNING: Opening or removing the UPS-covers will create the risk of exposure to dangerous voltages if power is connected to the UPS.

3.6.1 Safety notes

Please ensure you read and understand the following safety notes before you begin the UPS electrical installation.

1. All operations detailed in this section must be performed by an authorised electrician or qualified personnel.
2. Once the electrical installation is completed the initial UPS start-up must be performed by qualified personnel authorised by the manufacturer.
3. Do not operate the UPS if there is water or moisture present.
4. When carrying out any work on the UPS input power cables you must ensure that the UPS supplies are isolated at the supply distribution panel and, where possible, locked out. Warning notices should be posted where applicable to prevent inadvertent operation of the input supply isolators.

3.6.2 Preparation for the input cabling

Before you start connecting the UPS input cables:

- Ensure that the provided fuses and cables satisfy the ratings shown in Figures 3.4, 3.6 and 3.7, and are in accordance with the prescribed IEC Standards or local regulations (e.g. BS7671).
 - Do not commence this procedure until the UPS is properly installed at its intended location.

3.6.3 Connecting the UPS input power cables

1. To protect personnel during the UPS installation ensure that the connections are performed under the following conditions:
 - a) No mains voltage is present.
 - b) Loads are shut down and disconnected.
 - c) The UPS is shut down and voltage-free.
 - d) The UPS Maintenance Bypass Isolator IA1 is OFF.
 - e) The UPS Output/Parallel Isolator IA2 is OFF
2. Gain access to the UPS power terminals.
3. Connect the earth cable from the LV-Distribution Board to the protective earth (PE) busbar in the UPS, located adjacent to the power terminals, as shown in Figures 3.10, 3.11 and 3.12.
4. The Rehiko PW 5000/TP input supply can be wired for 'single feed' (standard) or 'dual feed' operation. Connect the input power cable coming from the LV-Distribution Board to the UPS input terminals following the 'single input feed' or 'dual input feed' given below.

Single Input Feed

1. Refer to the schematic drawing and connection table in Figure 3.8. Connect the UPS input supply cables to terminals 1L1, 1L2, 1L3 and 1N on the UPS main terminal block (see Figures 3.6 and 3.7). Ensure correct (clockwise) phase rotation.



CAUTION: The input Neutral cable must ALWAYS be connected.

2. Secure the cables to the fixing rail under the connection terminals.
3. 10kVA – 25kVA Models only: Ensure the bypass cables are connected to the correct terminals on the Filter Board (see Figure 3.6). These will be reconfigured by the commissioning engineer if necessary.
4. 25kVA – 50kVA 'C' cabinet models only: Ensure the single input feed links are fitted between the input and bypass supply terminal (see Figure 3.7).

Dual Input Feed

Refer to the schematic drawing and connection table in Figure 3.9.

1. The UPS is supplied (as standard) with facilities for a single cable feed for the rectifier and bypass supplies. For a dual feed configuration remove the links between 1L1-2L1; 1L2-2L2; 1L3-2L3 and 1N-2N, on the Input Terminal Block (see Figures 3.6 and 3.7).
2. Connect the UPS input supply cables to terminals 1L1, 1L2, 1L3 and 1N on the UPS main terminal block (see Figures 3.6 and 3.7). Ensure correct (clockwise) phase rotation.



CAUTION: The input Neutral cable must ALWAYS be connected.

3. Connect the UPS bypass supply cables to terminals 2L1, 2L2, 2L3 and 2N on the UPS main terminal block (see Figures 3.6 and 3.7). Ensure correct (clockwise) phase rotation.



CAUTION: The bypass Neutral cable must ALWAYS be connected.

4. Secure the cables to the fixing rail located below the connection terminals.
5. 10kVA – 25kVA Models only. Ensure the bypass cables are connected to the correct terminals on the Filter Board (see Figure 3.6). These will be reconfigured by the commissioning engineer if necessary.
6. 25kVA – 50kVA 'C' cabinet models only: Ensure the single input feed links are removed between the input and bypass supply terminal (see Figure 3.7). Leave the neutral (N) link in place.

3.7 Connecting the UPS output



WARNING: Opening or removing the UPS-covers will create the risk of exposure to dangerous voltages if power is connected to the UPS.

3.7.1 Safety notes

Please ensure you read and understand the following safety notes before you begin the UPS electrical installation.

1. All operations detailed in this section must be performed by an authorised electrician or qualified personnel.
2. Once the electrical installation is completed the initial UPS start-up must be performed by qualified personnel authorised by the manufacturer.
3. Do not operate the UPS if there is water or moisture present.
4. When carrying out any work on the UPS output power cables you must ensure that the UPS output is isolated at the load supply distribution panel, and where possible locked out. Warning notices should be posted where applicable to prevent inadvertent operation of the output supply isolators.

3.7.2 Preparation for the output cabling

Circuit breakers (or equivalent protection) must be fitted between the UPS output and load equipment to provide additional protection to the UPS in the event of an overload or short circuit, and also provide a means of isolating individual loads if required.

Before you start connecting the UPS output cables to the load distribution panel:

- Ensure that the potential (maximum) load does not exceed the UPS model output power rating (OUTPUT POWER) on the nameplate.
- Ensure the output circuit breakers are correctly sized with respect to the load and cable rating.
- The maximum total load rating and maximum load rating of the individual load sockets should be indicated on the output distribution board.
- The circuit breakers must comply with the prescribed IEC Standards (e.g. BS7671). It is recommended that a separate output distribution board is provided for the load.

3.7.3 Connecting the UPS output cables

1. To protect personnel during the UPS installation ensure that the connections are performed under the following conditions:
 - a) No input mains voltage is present.
 - b) All loads are shut down and isolated.
 - c) The UPS is shut down and voltage-free.
 - d) The UPS Maintenance Bypass Isolator IA1 is OFF (OPEN).
 - e) The UPS Parallel Isolator IA2 is OFF (OPEN).
2. Gain internal access to the UPS and remove the UPS terminal cover.
3. Connect the protective earth cable from the Load Distribution Board to the protective earth (PE) busbar in the UPS – located adjacent to the power terminals, as shown in Figures 3.10, 3.11 and 3.12.
4. Connect the UPS output supply cables to terminals 3L1, 3L2, 3L3 and 3N on the UPS main terminal block (see Figures 3.6 and 3.7). Ensure correct (clockwise) phase rotation.



CAUTION: *The output Neutral cable must ALWAYS be connected.*

5. Secure the cables to the fixing rail located below the UPS connection terminals.
6. Ensure the output cables are connected to the correct power terminals on the load distribution panel.

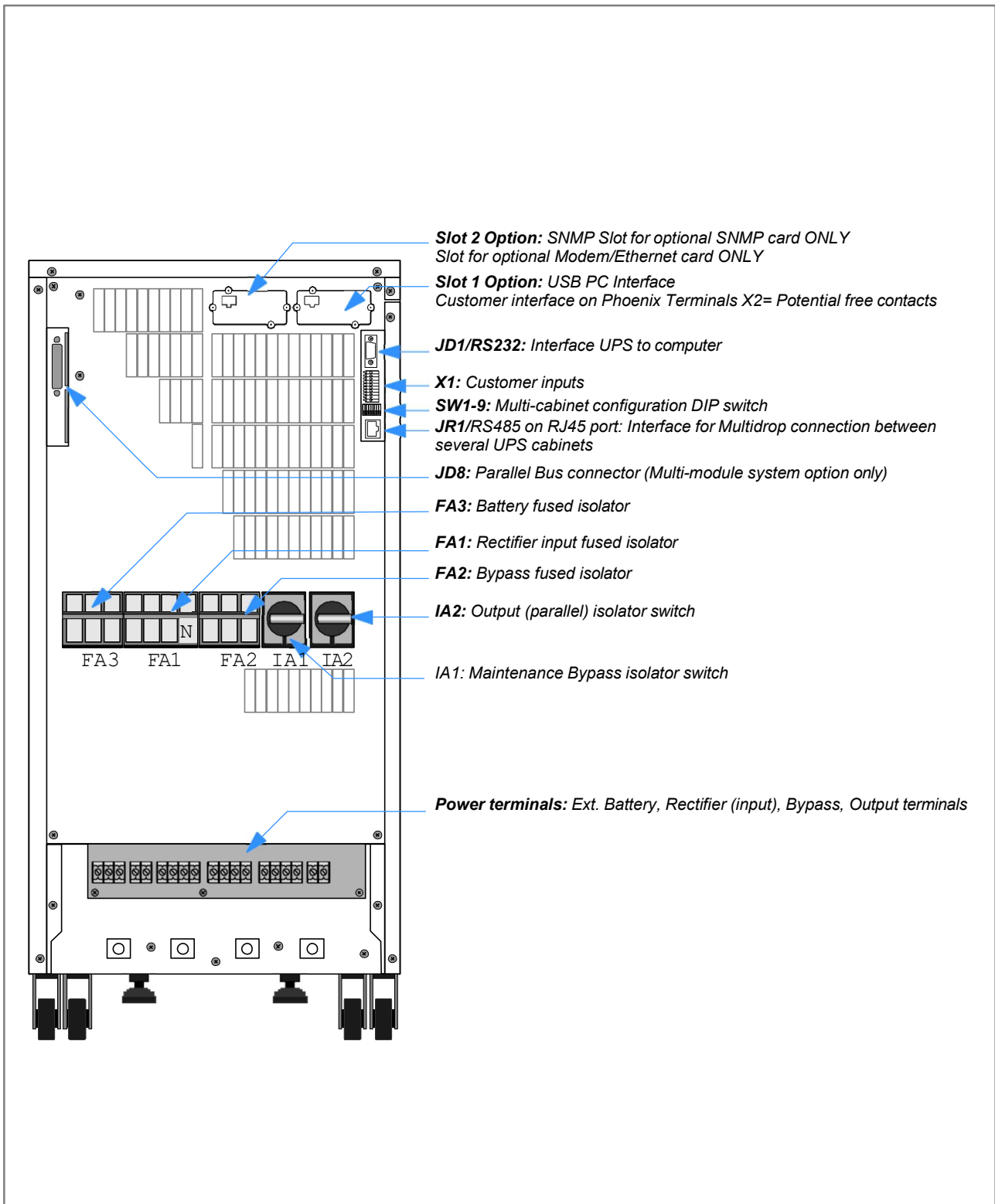

Figure 3.10 10 kVA–15 kVA Cabinet A connector details (rear view)

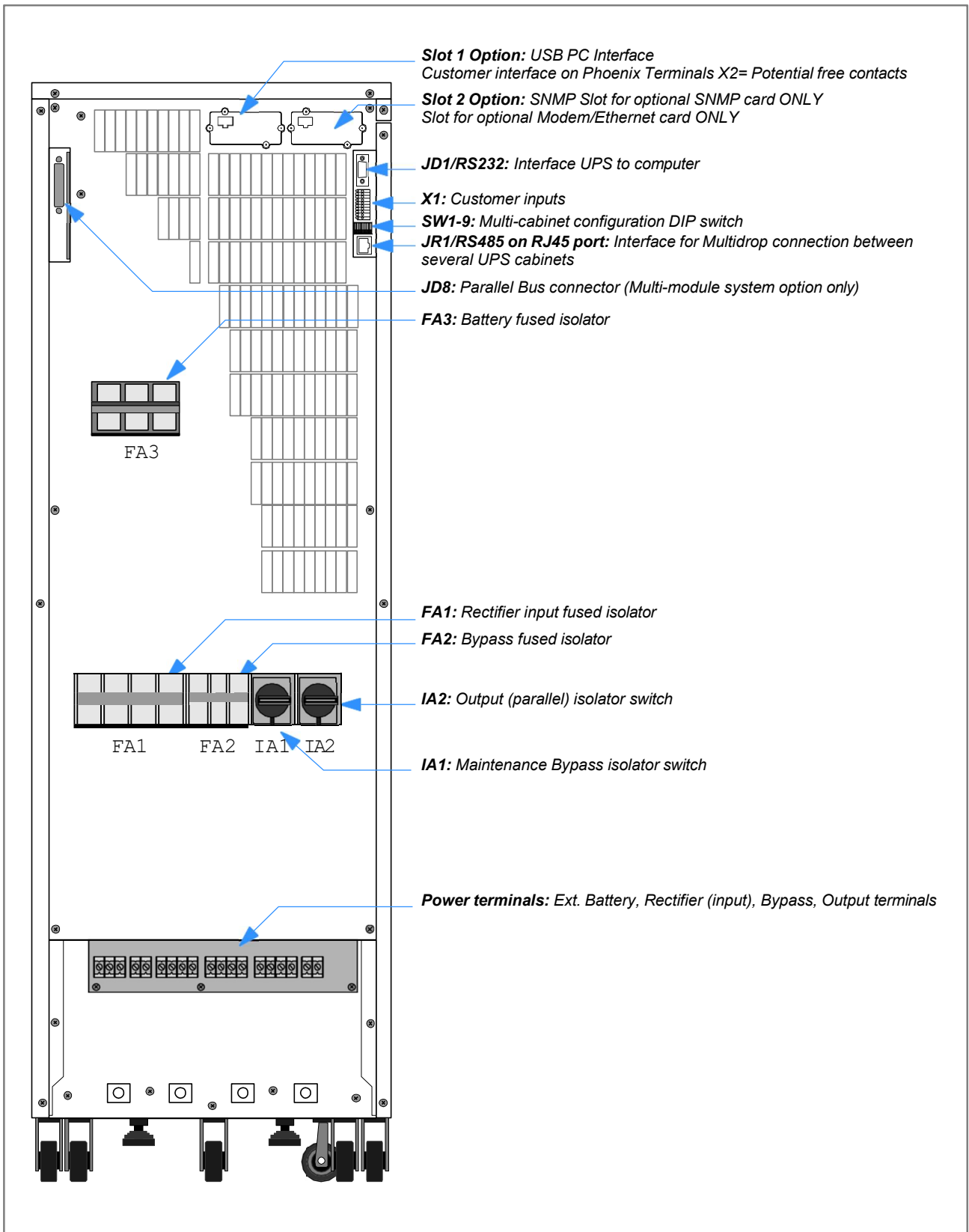

Figure 3.11 10 kVA - 25 kVA Cabinet B connector details (rear view)

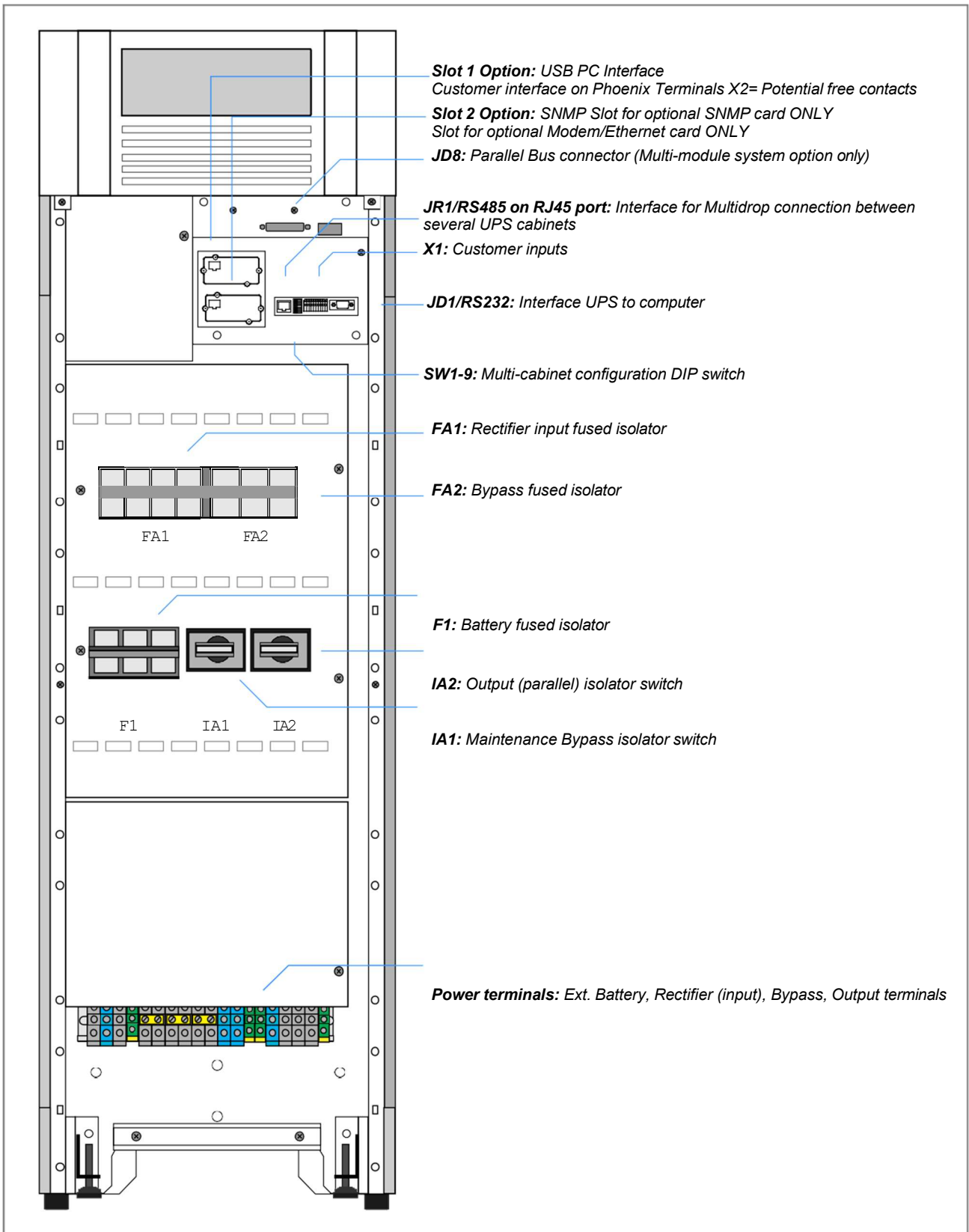

Figure 3.12 25 kVA - 50 kVA Cabinet C connector details (front view)

3.8 Battery connections



WARNING: The final assembly and connection of the battery units must be carried out by the commissioning engineer. Do not attempt to complete the battery wiring or close the battery isolators before this system has been commissioned

The cabinets are designed to house a number of 12V batteries of various capacities to provide a flexible, self-contained UPS system. Cabinets A & B can accept 7Ah or 9Ah batteries, while cabinet C can accept batteries of up to 28Ah. The batteries are connected in up to 48x12V strings and it is possible to connect 2 or 3 strings in parallel in Cabinets B & C, as shown in Figure 3.13, to enable a range of autonomy times to be achieved.

The final assembly and connection of the battery units will be carried out by the commissioning engineer.

3.8.1 Remote battery enclosures

If the UPS internal batteries are unable to provide the required autonomy times they can be replaced by a larger battery system mounted in a separate, external battery cabinet.

A range of matching battery enclosures are available, designed to suit individual site requirements. In each case the battery enclosure is fitted with a suitably rated fused isolator which is connected to the battery connection terminals inside the Rehko PW 5000/TP as shown in Figures 3.6 and 3.7.

Note: DC fuses and cables are bespoke to the installation.

3.8.2 Connecting the external battery enclosure



WARNING: This procedure must be carried out by (or under the supervision of) the system commissioning engineer.

To protect personnel during battery installation the connections must be made under the following conditions:

- Mains voltage must be disconnected from the UPS
 - All loads must be disconnected
 - The UPS and the external battery terminals must be voltage-free
1. The UPS must be totally shut-down and power-free.
Ensure the mains (and bypass) supply is isolated at the UPS input distribution board.
 2. Ensure that the MAINTENANCE BYPASS isolator (IA1) is open (OFF).
 3. Ensure that the battery isolator/fuses in the external battery cabinet (or racks) are open.
 4. Connect the protective earth cable (PE) between the UPS and external battery cabinet.
 5. Connect the corresponding +, N, - terminals between the UPS and external battery cabinet.
 6. The UPS battery isolator (FA3/F1) connections will require reconfiguring. This must be carried out by the commissioning engineer.

Note: The DC and Battery fuses and cabling are bespoke to the installation.

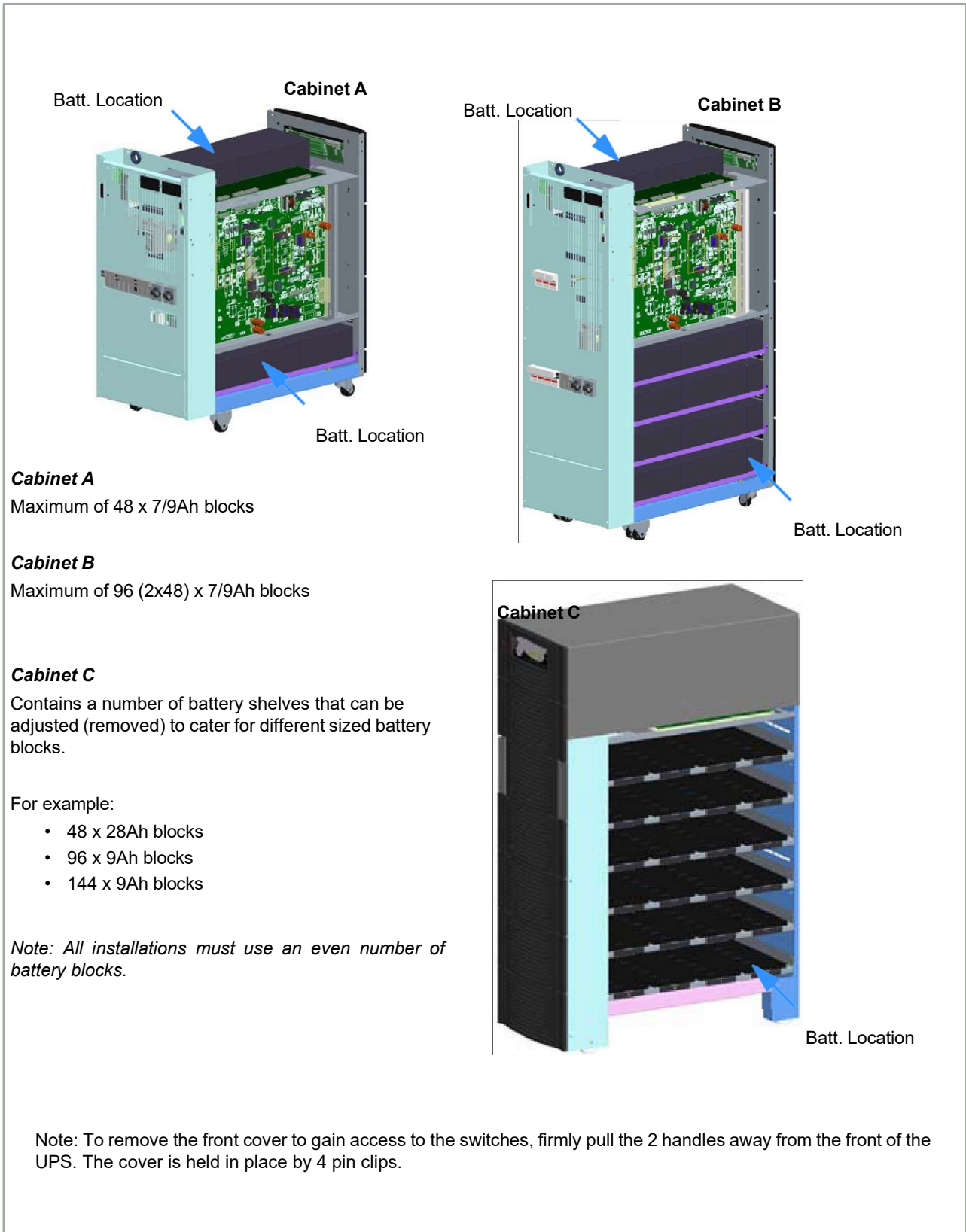

Figure 3.13 Internal battery locations

3.9 Multi-module control cabling and configuration



WARNING: When cabling the UPS cabinets, check with a voltmeter to confirm that each module power terminals are completely voltage free. Check that the Maintenance Bypasses isolator (IA1), Parallel Isolator (IA2) and Bypass Line isolator (FA2) are open (OFF) on all cabinets.

3.9.1 Connecting the parallel communication cables (Bus-lines)

In order to facilitate various parallel UPS control functions and operations (such as load sharing, frequency synchronisation, and load transfer) the paralleled UPS modules communicate with each other continuously by means of a communication Bus-line which takes the form of a signal cable connected between the modules.

The communication bus cables are daisy-chained between each module, as shown below in Figure 3.14. Once the cables are fitted, each module must be configured according to its position in the parallel system.

Note: This will be carried out by the commissioning engineer.

1. Connect the parallel control Bus-lines as follows:
2. Fit the Parallel Adaptor PCB (NW4019) to connector JD8 on all UPS-Cabinets (see Figures 3.10 and 3.12).
3. Set DIP Switch SW2-2 on each Parallel Adaptor according to the UPS cabinet's position in the parallel configuration (see Figure 3.14).
4. Connect a Bus-cable between PORT JD6 of UPS-Cabinet 1 Parallel Adaptor and PORT JD5 of UPS-Cabinet 2 Parallel Adaptor.
5. Connect a Bus-cable between PORT JD6 of UPS-Cabinet 2 Parallel Adaptor and PORT JD5 of UPS-Cabinet 3 Parallel Adaptor.
6. Continue with the above until a Bus-cable is connected to all modules.

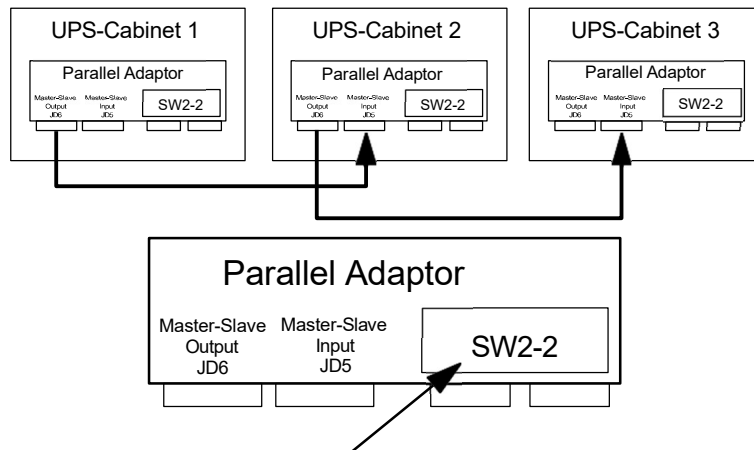

SW2-2 Configuration

	First Unit	Middle Unit	Last Unit	Single Unit
SW 1	OFF	OFF	ON	ON
SW 2	ON	OFF	OFF	ON

Figure 3.14 Bus-lines connections (3 Modules shown)

3.10 Module interfacing facilities

Each UPS is provided with communication port and a communication card, which provides system information:

Standard Interface Facilities	
JD1	Smart Port – RS232 Sub D9/female interface (UPS system to computer).
X1	Customer input interface (Phoenix terminals).
JR1	RS485 on RJ 45 port – Interface for Multidrop connection between several UPS cabinets.

Optional Facilities	
USB	PC Interface for remote signalling and automatic computer shutdown.
X2	Customer output interface on Phoenix terminals (Potential free contacts): <ul style="list-style-type: none"> • Common Alarm • Load On Bypass • Battery Low • Load on Inverter • Mains Failure
SNMP	Slot for optional SNMP card ONLY For monitoring and integration in network management.

3.10.1 JD1 Smart Port – Serial RS 232 and USB Port

The SMART PORT is an intelligent RS 232 serial port that allows the UPS to be connected to a computer. The connector is a standard D-Type, 9-pin, female, and the USB is a standard USB port.

When installed, the optional SMART PORT software, WAVEMON, allows the computer to monitor the mains voltage and the UPS-status continuously and display a message in the event of any UPS system changes.

Figure 3.15 and show the connection to a PC from the UPS for PC's with a 9 pin serial port and 25 pin serial port respectively.

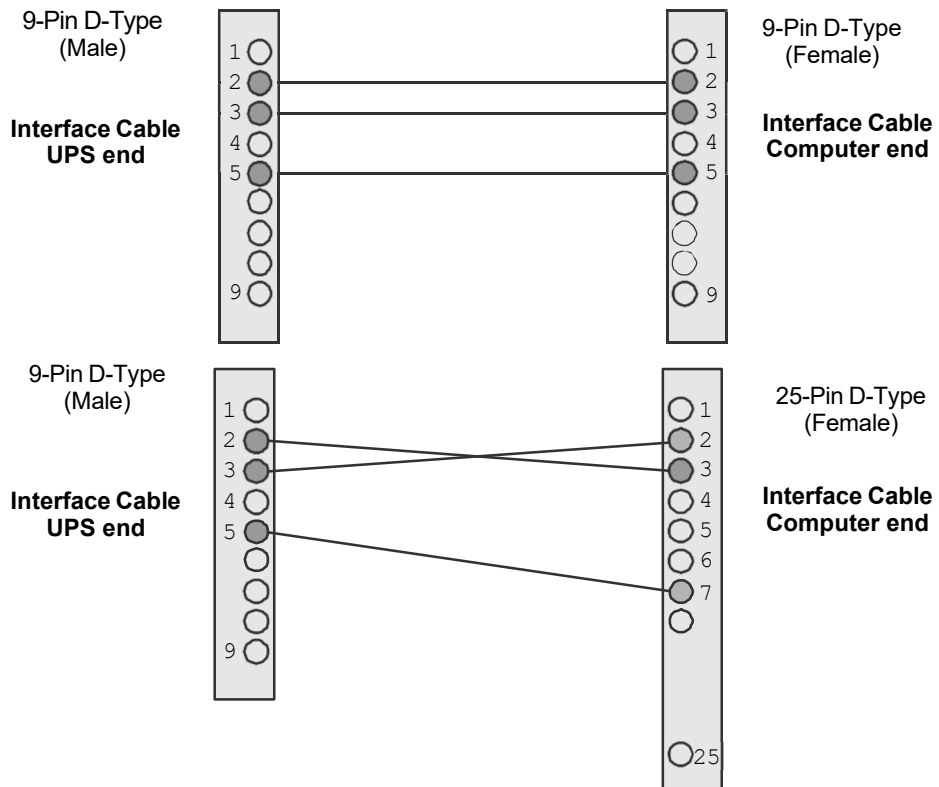

Figure 3.15 Connector Cable - PC Serial Port

3.10.2 X1 Dry Port (volt-free contacts)

All the Input and Output interfaces to X1 are connected to Phoenix terminals (cable 0.5mm²)

Connection of Remote Shut down facilities, Generator Operation, Customers specials (see also OPTIONS section).

Terminal	Contact	Signal	Function
X1/1	In	+12Vdc	Customer IN 1 (default as Generator Operation)
X1/2	Gnd	Gnd	(NC = Generator ON)
X1/3	In	+12Vdc	Customer IN 2
X1/4	Gnd	Gnd	(Function on request, to be defined)
X1/5	In	+3.3Vdc	Battery Temperature
X1/6	Gnd	Gnd	If connected, the battery charger current is temperature dependent
X1/7	In	+12Vdc	Remote shutdown
X1/8	Gnd	Gnd	Do not remove the factory mounted bridge until an external remote shut down is connected
X1/9	In	+12Vdc	12Vdc source
X1/10	Gnd	Gnd	Max 200mA load

3.10.3 JR1 / RS485 INTERFACE FOR MULTIDROP

The Computer Interface JR1 located on the distribution part is an intelligent RS485 serial port that allows system information to be gained from all modules which are connected in parallel using the Multidrop connection kit. (For details see user manual Multidrop kit). The connector JR1 is a standard RJ45 port.

3.10.4 X2 Dry Port – Optional Output Interfaces Terminal Block (X2)

Provision of signals for the automatic and orderly shutdown of servers, AS400 or Automation building systems. All voltage free contacts are rated 60 VAC max./500 mA max; 30VDC/1A; 60VDC/0.3A:



Pin	Contact	Signal	Function	
1		Alarm	MAINS_OK	Mains Present
2				Mains Failure
3				Common
4		Message	LOAD_ON_INV	Load On Inverter
5				Load on Mains (BYPASS MODE)
6				Common
7		Alarm	BATT_LOW	Battery Low
8				Battery OK
9				Common
10		Message	LOAD_ON_MAINS	Load On Mains (BYPASS-MODE)
11				Load on Inverter
12				Common
13		Alarm	COMMON_ALARM	Common Alarm
14				No Alarm Condition
15				Common

Figure 3.16 Dry Port (X2) Connections

4. Operation

4.1 Commissioning

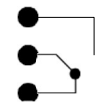
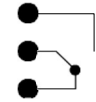
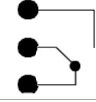
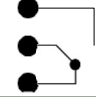
The Rehiko PW 5000/TP UPS is a high quality electronic machine that must be commissioned by a fully trained and authorised Rehiko field service engineer before being put into use.

Commissioning the UPS involves connecting the UPS battery, checking the electrical installation and operating environment of the UPS, performing a controlled start-up and testing of the UPS system, and customer training.



WARNING: Any Rehiko PW 5000/TP UPS system not commissioned by a Rehiko field service engineer must be considered an electrical hazard, and Rehiko accepts no responsibility for its safe operation or the safety of any personnel. Additionally, the manufacturer's warranty is immediately invalidated if the UPS is put into use before it has been correctly commissioned.

4.2 Control Panel

The user-friendly control panel is composed of three parts:

- Power Management Display (PMD)
- Mimic LED Indicators
- Operating keys

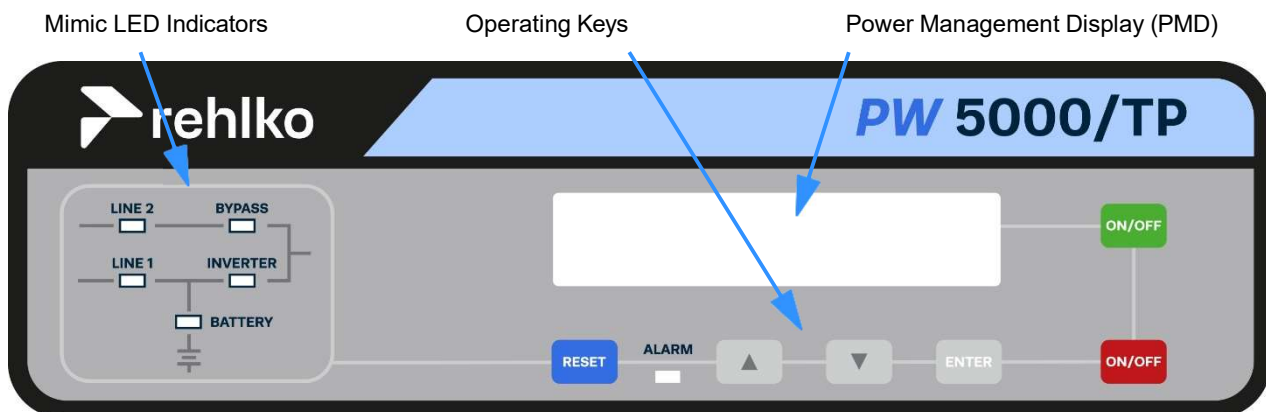

Figure 4.1 Control Panel

4.2.1 Power Management Display (PMD)

The 2 x 20 character LCD Power Management Display simplifies communication with the UPS and also provides UPS monitoring information (see paragraph 4.3).

The menu driven LCD enables the access to:

- The 'Event register'
- Monitoring the input and output voltage, current, frequency & power
- Monitoring battery run time
- Perform commands such as UPS start-up and shut-down, Load transfer from INVERTER to BYPASS and vice-versa
- Diagnostic (service mode only)
- Adjustments and testing (service mode only)

4.2.2 Mimic LED indicators

The mimic diagram indicates the status of the general UPS power flow and change colour between Green and Red (and OFF) to indicate the UPS operating conditions.

LINE 1 (rectifier) and LINE 2 (bypass) indicate the availability status of the mains power supply.

INVERTER and BYPASS, if green, indicate which of the two sources is supplying the critical load power.

The BATTERY LED indicator flashes when the battery is supplying the load – e.g. following a mains failure.

The ALARM LED is a visual indication of any internal or external alarm condition. When activated, it is accompanied by an audible alarm.

LED Indication summary

Indicator	Indicator Status	Interpretation
LINE 1	GREEN RED	Mains available Mains not available
LINE 2	GREEN RED	Mains bypass OK Mains bypass not OK or not present
ALARM	OFF Flashing RED + buzzer RED	No alarm condition Alarm condition Alarm condition (has been reset)
INVERTER	GREEN RED OFF	Load on inverter Inverter fault (load not transferable to inverter) Inverter not operating
BY-PASS	GREEN OFF	Load on bypass Bypass not operating
BATTERY	GREEN RED Flashing GREEN	Battery OK Battery fault or discharged On Battery

4.2.3 Operator keys

The operator keys allow the user to:

- Make settings and adjustments via the menu driven LCD display
- Start-up and shut down the UPS and transfer the load between inverter and bypass
- Monitor and display the UPS operating voltages, currents, frequencies and other values on the LCD display

Key function summary

Keys	Function
ON/OFF ON/OFF	Used to switch-on or switch-off the UPS (Both keys must be pressed simultaneously for ON/OFF operation).
UP (▲)	Scroll upwards through a displayed menu.
DOWN (▼)	Scroll downwards through a displayed menu.
RESET	Cancels the audible alarm. If the alarm condition was transient the ALARM LED will also extinguish, otherwise it will remain ON (red).
ENTER	Confirms (selects) a chosen menu item.

ON/OFF Start-up and shutdown buttons

The UPS may be switched ON or OFF by simultaneously pressing both ON/OFF keys on the control panel. This is to prevent accidental UPS start-up or shutdown.

Note: When the UPS is under normal operation, pressing the two ON/OFF buttons simultaneously will immediately shut down the UPS. In a single module installation this will disconnect the UPS from the load. In a parallel module system the

UPS module will shutdown and the module will effectively be disconnected from the parallel load bus; however, the load may or may-not transfer to the bypass supply in the remaining modules depending on the available module redundancy. To shut down all the modules in a parallel system you must press both ON/OFF buttons on every UPS cabinet!



CAUTION: If the ON/OFF buttons are operated (with no redundancy) while the UPS is not in Maintenance Bypass it will interrupt the load power supply.

4.3 Description of the LCD display

4.3.1 Status screens

DESCRIPTION	LCD-DISPLAY
1. Load is protected by UPS power supplied by inverter (normal operation).	LOAD PROTECTED P01
2. Load is not protected by UPS power –supplied by mains power (load on bypass)	LOAD NOT PROTECTED P01
3. Load supply interrupted. UPS has been switched off by “ON/OFF” buttons.	LOAD OFF SUPPLY FAILURE P01
4. The UPS/module is not supplying load. The output switch is open.	LOAD DISCONNECTED P01 PARALLEL SWITCH OPEN

On the right hand side of the LCD there is a 3 digit indicator which shows a module’s position in a multi-module system. The maximum number of modules that can be used in a parallel system is 20.

S	Stands for Single Module. The system consists only of one module.
P01	Stands for Parallel Cabinet in a multi-module system and 01 stands for the first cabinet (MASTER) in the multi-module system.
P02	Stands for Parallel Cabinet in a multi-module system and 02 stands for the second Cabinet (SLAVE) in the multi-module system (the number can range from 02 to 20 depending on the module’s position in the parallel system).

Note: The definition of the cabinet position is set by the commissioning engineer.

Definition of the module position in a Single/Multi-module chain

The position of a module in a multi-module configuration is set by DIP Switch SW1-9 (see paragraph 3.10 on page 27):

- **First** – First UPS module in the parallel configuration chain
- **Middle** – UPS module in the middle of the parallel configuration chain (there may be more than one ‘middle’ UPS)
- **Last** – UPS module is last in the parallel configuration chain.

If a UPS is operating as a Single module then it is seen as the First and Last in an imaginary chain.

4.3.2 Main menu screen

DESCRIPTION	LCD-DISPLAY
1. A log of the last 99 events is stored in the Power Management Display (see paragraph 4.3.3).	→ EVENT LOG MEASUREMENTS
2. Allows monitoring of voltages, power, frequencies, currents, autonomy etc (see paragraph 4.3.4)	→ MEASUREMENTS COMMANDS
3. Enables the commands "Load to inverter", "Load to bypass" and battery test to be executed (see paragraph 4.3.5).	→ COMMANDS SET-UP DATA
4. Allows the UPS personalized information (such as serial number) to be entered (see paragraph 4.3.6).	→ SET-UP DATA SET-UP USER
5. Allows user to set up Date/Time, automatic battery test, etc. (see paragraph 4.3.7)	→ SET-UP USER SET-UP SERVICE
6. Password-protected area for service engineer use only (see paragraph 4.3.8).	→ SET-UP SERVICE

4.3.3 Event log menu screen

DESCRIPTION	LCD-DISPLAY
1. Logging Control; a log of the last 99 events is stored in the Power Management Display.	01 05-10-08 14-38-56 LOAD TO INV.
2. Every stored event is identified with a sequential number and time stamp.	02 05-10-08 14-38-59 LOAD TO BYP.
3. By pressing ENTER the code of the event will be displayed.	03 05-10-08 14-39-14 LOAD OFF

4.3.4 Measurements menu screen

DESCRIPTION	LCD-DISPLAY
1. Battery Runtime	BATT. RUN TIME (MIN) 00h 00mm
2. UPS-Output Frequency	OUTPUT FREQUENCY (HZ) 50.00
3. Bypass Frequency.	BYPASS FREQUENCY (HZ) 50.00
4. Battery Voltage	BATTERY VOLTAGE (V) +0.0 - 0.0
5. Battery Charger Current	BATT. CHARGE CUR. (A) + 0.0 - 0.0

DESCRIPTION	LCD-DISPLAY
6. Battery Discharge Current.	DISCHARGE CURRENT (A) 00.00
7. Rectifier Input Voltage (all three phases)	RECTIFIER VOLTAGE (V) 230 230 230
8. Bypass Input Voltage (all three phases)	BYPASS VOLTAGE (V) 230 230 230
9. Output Voltage (all three phases)	OUTPUT VOLTAGE (V) 230 230 230
10. Output Current (all three phases)	OUTPUT CURRENT (A) 00.00 00.00 00.00
11. Active Output Power (all three phases)	ACTIVE POWER (KW) 00.00 00.00 00.00
12. Reactive Output Power (all three phases)	REACTIVE POWER (kVAr) 00.00 00.00 00.00
13. Apparent Output Power (all three phases)	APPARENT POWER (KVA) 00.00 00.00 00.00
14. Output Power (all three phases)	OUTPUT POWER (%) 00.00 00.00 00.00
15. Battery capacity	BATT. CAPACITY (%) 00

4.3.5 Commands menu screen

DESCRIPTION	LCD-DISPLAY
1. Transfer Load to inverter	→ LOAD TO INVERTER LOAD TO BYPASS
2. Transfer Load to bypass.	→ LOAD TO BYPASS PERFORM BATT.TEST
3. Battery Test	→ PERFORM BATT.TEST

4.3.6 UPS Data menu screen

DESCRIPTION	LCD-DISPLAY
1. These general UPS Data are installed at the manufacturing plant.	UPS SERIAL NUMBER nn-nnnnn
2. Manufacturing date	DATE OF MANUFACTURE 15-03-11
3. EPROM Version	EPROM VERSION V-000
4. Actual Date and Time	DATE TIME dd-mm-yyyy hh:mm:ss

4.3.7 Set-up User menu screen

DESCRIPTION	LCD-DISPLAY
1. Set-up language	<div style="border: 1px solid black; padding: 2px;">→ SET LANGUAGE SET DATE AND TIME</div> <div style="border: 1px solid black; padding: 2px;">ENGLISH FRANCAIS DEUTCH DUTCH SPANISH POLISH PORTOGUESE</div>
2. Set-up Date and Time	<div style="border: 1px solid black; padding: 2px;">→ SET-UP DATE/TIME SET-UP BATT. TEST</div> <div style="border: 1px solid black; padding: 2px;">DD-MM-YY HH-MM-SS</div>
3. Set-up battery test	<div style="border: 1px solid black; padding: 2px;">→ SET-UP BATT. TEST SET-UP GEN-SET OPER.</div> <div style="border: 1px solid black; padding: 2px;">DAY OF MONTH (1-31)</div> <div style="border: 1px solid black; padding: 2px;">HOUR OF DAY (0-23)</div> <div style="border: 1px solid black; padding: 2px;">REPETITIVE (Y/N) YES/NO</div>
4. Set-up operation with Gen-Set	<div style="border: 1px solid black; padding: 2px;">→ SET GENERATOR OP.</div> <div style="border: 1px solid black; padding: 2px;">BATT.CHARGE LOCK YES/NO</div> <div style="border: 1px solid black; padding: 2px;">BYPASS LOCK YES/NO</div>

4.3.8 Set-Up Service menu screen

DESCRIPTION	LCD-DISPLAY
1. This password-protected Menu is reserved for authorized service engineers. It is not to be used by End-Users.	<div style="border: 1px solid black; padding: 2px;">→ SET-UP SERVICE PASSWORD</div>
2. Type in password	<div style="border: 1px solid black; padding: 2px;">→ PASSWORD*</div>



Key Point: It is essential to enter the password.

From within the Set-up Service menu a service engineer can adjust the UPS voltages, frequencies, currents, power and autonomies, together with setting up:

- UPS Rated Power
- Module configuration S, P01, P02...
- Single (standard) or Dual input feed
- Frequency-converter, 50/60Hz and 60/50Hz
- Synchronisation window (2-4%)

4.4 Operating Modes

4.4.1 On-Line (Inverter) mode

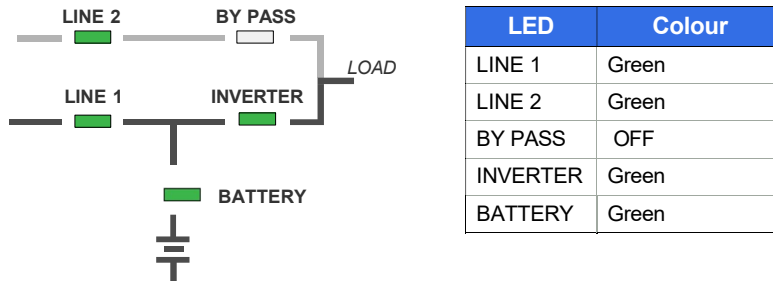

Figure 4.2 On-Line Mode

When the UPS is operating in the On-Line mode the load is supplied through the LINE 1 (RECTIFIER) and INVERTER. This mode provides the highest degree of protection, especially in the event of a mains disturbance or failure, and is always recommended if the critical loads (computer systems) will not tolerate any (even very brief) interruption of the supply.

In the unlikely event of an inverter fault or overload condition the UPS will transfer the load automatically, and without interruption, to the static bypass supply (transfer time = 0).

4.4.2 Bypass (Line-Interactive) mode

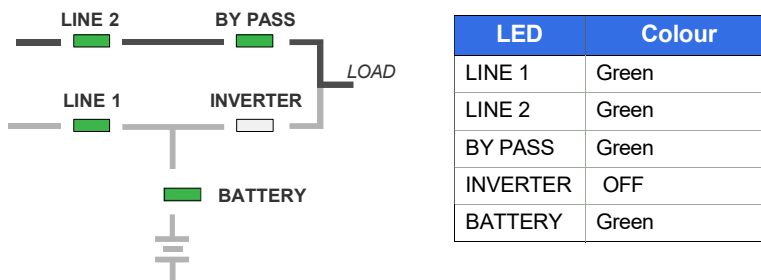

Figure 4.3 Line-Interactive (Bypass Mode)

In the Bypass (Line-Interactive) mode the load is supplied from the bypass mains (LINE 2) and the static BYPASS. In the event of a mains failure the load is automatically transferred to the inverter within 3 to 5 msec – this is valid for single and parallel module systems. The battery charger remains active in this mode.

Although this mode of operation offers greater efficiency than the On-Line mode, it is recommended only if the loads can tolerate interruptions of 3 to 5 ms – which is the transfer time taken to change from Bypass mode to On-Line mode.



WARNING: The On-Line mode must always be used to provide maximum load protection.

4.4.3 Maintenance Bypass Mode

Maintenance bypass operation in a 'single module' and '1+1 redundant' system

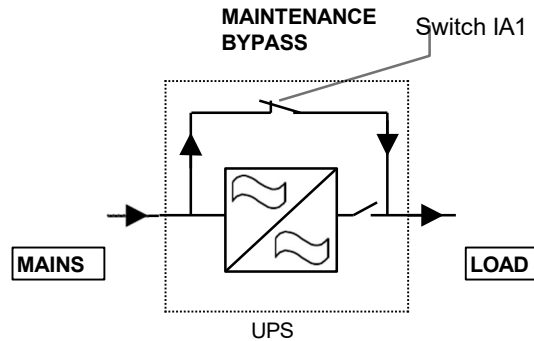

Figure 4.4 Maintenance Bypass Mode

Each module is fitted with a Maintenance Bypass switch (IA1) which, when closed, connects the UPS module output terminals directly to the UPS bypass mains supply. In a 'single module' or '1+1 redundant' installation, this facility enables a UPS module to be shut down for maintenance or repair whilst maintaining the load on the raw (unprotected) maintenance bypass supply.

Note: When switching to this mode BOTH the UPS modules in a '1+1 redundant' system must first be selected to the Bypass mode.

The Maintenance Bypass mode is effected by means of the IA1 BYPASS SWITCH:

Switch IA1	Effect
ON	Maintenance Bypass-Switch Closed (Load on bypass mains) LCD-indication: MAINTENANCE BYP CLOSED LED Indicators will indicate as shown in table below
OFF	Bypass-Switch Open – Normal operating condition (Load on inverter) LCD-indication MAINTENANCE BYP OPEN LED Indicators will indicate as shown in table below.

LED Indicator	ON	OFF
LINE 1	Green	Green
LINE 2	Green	Green
BYPASS	Green	OFF
INVERTER	RED	ON
BATTERY	Green	Green



CAUTION: *If the UPS is operating in the Maintenance Bypass mode the load will not be protected in the event of a mains failure. It is therefore strongly recommended to switch over to the on-line mode or bypass mode as soon as possible.*

Maintenance bypass in a multi-module parallel system

In a 'multi-module' parallel UPS system the maintenance bypass switch (IA1) in an individual UPS module is not rated to carry the full system load and should never be closed. In this type of system the maintenance bypass circuit is provided by a single external circuit breaker that wraps around the entire UPS system. For reasons of safety, and sustaining the load

during switch-over, the external maintenance bypass circuit breaker is normally interlocked with the UPS input mains supply circuit breaker at the mains distribution panel.



WARNING: DO NOT CLOSE THE MAINTENANCE BYPASS SWITCH (IA1) ON A UPS MODULE IN A MULTI-MODULE PARALLEL SYSTEM. DOING SO COULD CAUSE PERSONAL INJURY, EQUIPMENT DAMAGE OR INTERRUPT THE LOAD SUPPLY.

4.4.4 Multi-module configuration concept

Up to 20 Rehiko PW 5000/TP UPS modules can be connected in parallel to provide increased power capacity or redundancy operation.

Note: Although the UPS single/multi configuration can be modified in the field it is generally specified on ordering so that the module can be configured and fully tested in the factory prior to despatch.

When operating in a parallel system, the Rehiko PW 5000/TP configuration presents a decentralised bypass architecture – i.e. each UPS module is provided with its own static bypass. Ribbon cables are connected between adjacent modules to enable ‘system level’ control of load transfer, frequency synchronisation, load sharing etc.

Within the parallel control system there is always one ‘master’ module with the remaining modules acting as ‘slaves’, and if at any time the master goes faulty the next module in the chain (a former slave module) will immediately take over the role of master, and the former master will switch off. Master/slave configuration is achieved through selector switches located in each cabinet and is set-up during commissioning (see paragraph 3.10).

Parallel Isolator (IA2)

Every UPS-module is provided with an output parallel isolator (IA2) which can be used to take the UPS off-line if required. When IA2 is open it isolates the module’s output from the parallel bus (and therefore from the load) and there is no power being provided by the inverter.

IA2 Switch	EFFECT
CLOSED (ON)	Normal operation (Load power is being supplied by the UPS)
OPEN (OFF)	UPS module is isolated from the Parallel Load Bus for maintenance or module replacement (UPS-Module is not supplying load power)

Note: In a redundant module system one (or more) module(s) is permitted to be taken off-line without affecting the remaining, on-line modules. If the number of off-line modules exceeds the system redundancy the load is transferred to bypass.

ON/OFF Start-up and shutdown buttons

The ON/OFF buttons on the Operator Control Panel are used to Start and Stop the UPS module. Once again, when the module is part of a redundant module system, stopping one module using these buttons will shut down the affected module only, and will not cause the remaining modules to shutdown or necessarily transfer the load to bypass unless the number of shut down modules exceeds the system redundancy.

Load transfer commands

The load is normally transferred between the inverter and bypass supply via the control panel commands menu. In a parallel system, if you activate the LOAD TO BYPASS command on any module then all the modules will simultaneously transfer the load to their bypass supply. Conversely, when operating ON BYPASS if you perform the command LOAD TO INVERTER on any module *all the UPS modules* will simultaneously transfer the load to their inverters (provided a sufficient number of modules are operating to satisfy the system redundancy requirements).

4.5 Operating Instructions

Under normal operating conditions all the UPS modules in a multi-module system are running, and operating in the 'On Line' (On Inverter) mode.

The following procedures are provided in this section:

How to transfer the load to the Maintenance Bypass and shut down the UPS system for maintenance purposes – (see paragraph 4.5.1).

How to start up the UPS system and transfer the load from the Maintenance Bypass to the inverters ('On Line' mode) – (see paragraph 4.5.2).

How to shut down the entire UPS system – (see paragraph 4.5.3).

How to stop and start one module in a redundant multi-module system – (see paragraph 4.5.4).

4.5.1 Transfer to Maintenance Bypass Mode

If needed, to perform service or maintenance, it is possible to transfer the load to Maintenance Bypass Mode and power down the UPS module(s) whilst leaving the load connected to the raw bypass mains supply.



WARNING: Before you close the Maintenance Bypass isolator ensure that the UPS is operating in the Bypass Mode.

All the operations in this section must be performed by authorised and trained personnel.

This procedure describes the sequence of operations to transfer the load to the Maintenance Bypass supply and then shut down, and isolate, the UPS Module(s).

Prior to commencing this procedure, check and confirm the following UPS system status (on all cabinets in a multi-module system):

- The mimic panel LED indications should be as per the following table (on all cabinets in a multi-module system):

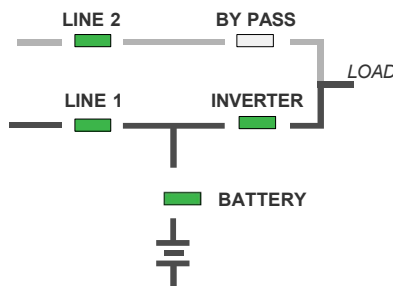

LED	Colour
LINE 1	Green
LINE 2	Green
BY PASS	OFF
INVERTER	Green
BATTERY	Green

- The LCD panel should display LOAD PROTECTED. If anything other than LOAD PROTECTED is displayed then press the RESET button, and if LOAD PROTECTED is still not displayed there is a problem with the UPS – seek assistance!

Transferring the UPS to 'Bypass' mode:

- On any one of the UPS module's mimic panel press the ENTER key once to access the menu system.
- Using the UP/DOWN keys, move the cursor so that it is adjacent to COMMANDS and then press the ENTER key.
- Using the UP/DOWN keys, move the cursor so that it is adjacent to LOAD TO BYPASS and then press the ENTER key.
 - The UPS system will transfer the load to static bypass.
- On all modules in a multi module system check and confirm that:
 - The INVERTER LED has extinguished.
 - The BYPASS LED is green.
 - The LCD displays LOAD NOT PROTECTED.

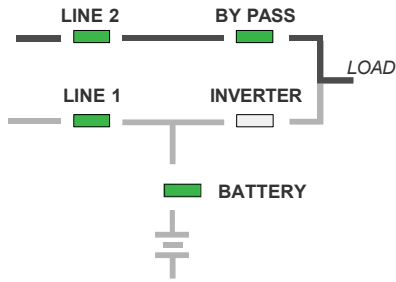

LED	Colour
LINE 1	Green
LINE 2	Green
BY PASS	Green
INVERTER	OFF
BATTERY	Green

Closing the Maintenance Bypass switch:

Note: The following instructions are for a 'single module' or '1+1 redundant' system only. In a 'multi-module parallel' system, close the external maintenance bypass circuit breaker in accordance with local instructions (see paragraph 4.4.3 on page 38).

5. Close the Maintenance Bypass switch IA1.
6. On all modules check and confirm that:
 - a) The INVERTERLED has turned to red.
 - b) The BYPASSLED is green.
 - c) The LCD displays MANUAL BYP IS CLOSED.

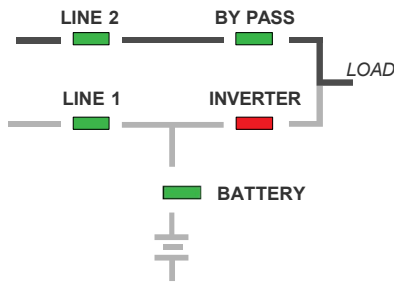

LED	Colour
LINE 1	Green
LINE 2	Green
BY PASS	Green
INVERTER	RED
BATTERY	Green

Powering down a UPS module:

When the load is connected to the Maintenance Bypass supply, as described above, the UPS module(s) can be powered down (for example, if required for maintenance/testing) using the following procedure:

Note: Carry out the following procedure on each module in a parallel system.

7. On the UPS control panel simultaneously press both ON/OFF buttons.
 - a) The LCD panel will indicate: LOAD OFF, SUPPLY FAILURE.
8. Open the battery fuse/isolator.
 - a) Open FA3/F1 if using internal batteries.
 - b) If using external batteries open the battery fuses/isolator on the associated battery cabinet/rack.
9. On the UPS module open the module's Parallel Isolator (IA2).

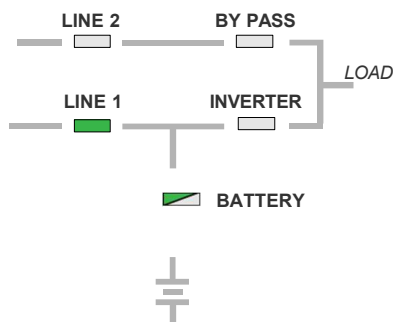

LED	Colour
LINE 1	Green
LINE 2	Off
BY PASS	Off
INVERTER	Off
BATTERY	Green Flashing

10. Open the Bypass Line fuse holder FA2 and the Rectifier Line fuse holder FA1.



WARNING: The UPS module is still live at its input and output power terminals due to the activation of Maintenance Bypass circuit.
WARNING: Allow 10 minutes for the internal DC capacitors to discharge before touching any UPS internal components.
WARNING: The load is now supplied from the bypass mains and is not protected against power failure.

4.5.2 Starting the UPS system from the Maintenance Bypass

This procedure describes the sequence of operations necessary to power up the UPS module(s) whilst the load is connected to the Maintenance Bypass supply, and then transfer the load to the UPS Inverter(s) ('On-Line' mode).



WARNING: All the operations in this section must be performed by authorised and trained personnel.

Prior to powering-up the system, check and confirm the UPS system status:

- The load is supplied via the Maintenance Bypass switch (in all modules)
- The UPS module(s) are powered down

Powering up the UPS Module(s):

In a multi-module system perform each of the steps in turn on every module.

1. On the UPS module close the Bypass Line fuse holder FA2 and the Rectifier Line fuse holder FA1 if they are open.
2. Close the battery fuse FA3/F1 (if using internal batteries), or the battery fuse/isolator on the external battery cabinet/ rack (where used).
 - a) The UPS mimic panel LINE 1LED will be permanent green.
 - b) The BATTERYLED will be flashing green.
 - c) The LCD display will indicate LOAD OFF, SUPPLY FAILURE.

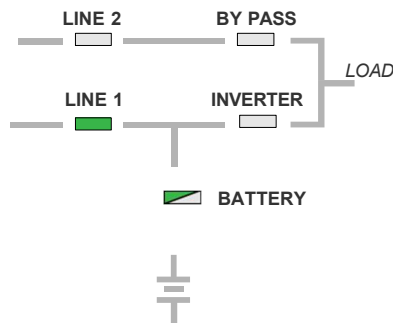

LED	Colour
LINE 1	Green
LINE 2	Off
BY PASS	Off
INVERTER	Off
BATTERY	Green Flashing

3. Close the Parallel Isolator switch (IA2) and check that the PARALLEL SW CLOSED message is shown on the LCD display.
4. On the UPS mimic panel press and release both ON/OFF buttons simultaneously and wait approximately 60 seconds.
 - a) The UPS module will begin to power up.
 - a) Initially LINE 2LED will be red, then change to green.
 - a) At this stage the LCD display will indicate LOAD NOT PROTECTED and the module mimic LED indications should be as follows:

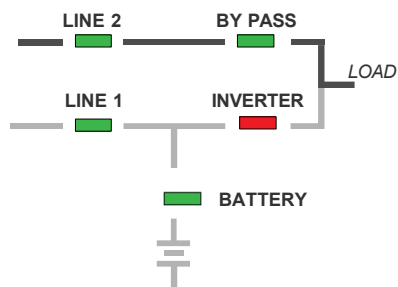

LED	Colour
LINE 1	Green
LINE 2	Green
BY PASS	Green
INVERTER	RED
BATTERY	Green

- When powering up a multi-module system ensure that ALL the modules are in the state shown above before continuing with this procedure.

Transferring to the UPS from the Maintenance Bypass:

Note: The following instructions are for a 'single module' or '1+1 redundant' system only. In a 'multi-module parallel' system, open the external maintenance bypass circuit breaker in accordance with local instructions (see paragraph 4.4.3 on page 38).

- Ensure that the BYPASSLED is green (on all modules).
- Open the Maintenance Bypass switch (IA1) (on all modules).
 - The LCD panels will display MANUAL BYPASS OPEN.
 - The INVERTERLED will be extinguished.
 - An audible alarm will sound.

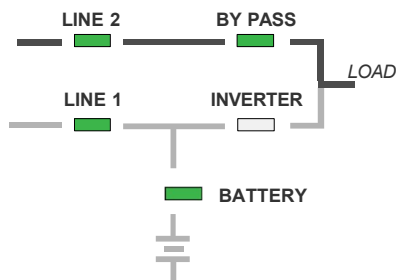

LED	Colour
LINE 1	Green
LINE 2	Green
BY PASS	Green
INVERTER	Off
BATTERY	Green

- Press the RESET button to cancel the audible alarm (on all modules).
 - The LCD display(s) will now indicate LOAD NOT PROTECTED.

Transferring the load to the inverter:

- On the Control Panel (of any one module in a multi-module system):
 - Press the UP key once to access the menu system.
 - Use the UP/DOWN keys to move the cursor so that it is adjacent to COMMANDS and then press the ENTER key.
 - Use the UP/DOWN keys move the cursor so that it is adjacent to LOAD TO INVERTER and then press the ENTER key.
- The UPS system will transfer the load to Inverter (on all modules in a multi-module system).
 - The LCD display(s) will now indicate LOAD PROTECTED.
 - Check and confirm that the LED display(s) are as shown below:

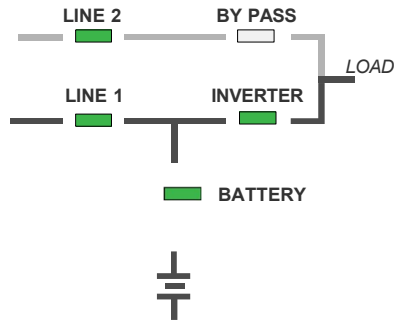

LED	Colour
LINE 1	Green
LINE 2	Green
BY PASS	Off
INVERTER	Green
BATTERY	Green

11. The UPS is now operating in 'On-Line' mode. The load is protected and supplied by inverter power.

4.5.3 Complete system shutdown

The UPS system may be shutdown completely if the load does not need input power for an extended period of time. Use this procedure to turn off the load power and shutdown the entire UPS system.



WARNING: All the operations in this section must be performed by authorised and trained personnel.



CAUTION: This procedure will totally disconnect load power. Ensure that it is safe to lose power to all the loads connected to the UPS system before you begin this process.

1. Isolate all load equipment connected to the output of the UPS system by opening the fused isolators or circuit breakers in the UPS output load distribution board.



WARNING: Perform the following steps only after the load has been fully isolated.

2. Verify that the loads are powered down. Then carry out the following actions on every module in a multi-module system.
3. On the UPS control panel simultaneously press both ON/OFF buttons.
 - a) The LCD panel will indicate: LOAD OFF, SUPPLY FAILURE.
4. Open the battery fuse/isolator.
 - a) Open FA3/F1 if using internal batteries.
 - b) If using external batteries open the battery fuses/isolator on the associated battery cabinet/rack.
5. Open the module's Parallel Isolator switch (IA2).

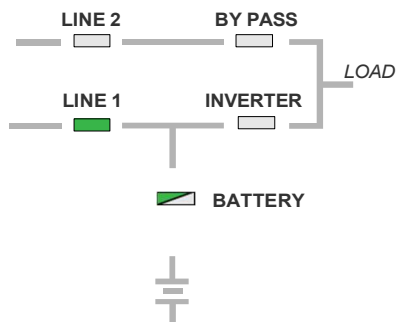

LED	Colour
LINE 1	Green
LINE 2	Off
BY PASS	Off
INVERTER	Off
BATTERY	Green Flashing

6. Open the Bypass Line fuse holder FA2 and the Rectifier Line fuse holder FA1.
7. Open the UPS Input and Bypass supply fused isolators (or breakers) in the building power distribution panel.
8. The UPS is now voltage free.



WARNING: Allow 10 minutes for the internal DC capacitors to discharge before touching the UPS internal components.

4.5.4 Individual module start/stop procedure

If a multi-module system is designed with built-in redundancy it is possible to stop and start one module without affecting the operational status of the overall system – e.g. one module can be taken off-line for servicing whilst the remaining modules maintain the protected load supply.



WARNING: All the operations in this section must be performed by authorised and trained personnel.

Module start-up:

Use this procedure to start a module and connect it to a multi-module system.

This procedure assumes the following initial conditions:

- UPS input isolators are open on the building's LV supply switchboard
 - The fused battery isolator(s) are open
 - In the UPS cabinet, the fused isolators FA1, FA2 and the parallel isolator (IA2) are open
1. In the UPS cabinet, close the Input supply and Bypass supply fused isolators FA1, FA2 and the Parallel Isolator IA2.
 2. Close the UPS input supply isolator at the LV switchboard.
 - a) The LINE 1 indicator will illuminate green.
 - b) The LCD display will indicate LOAD OFF SUPPLY FAILURE.

Note: If necessary press the RESET button to obtain this display indication.

3. Close the battery fuse/isolator.
 - a) Close FA3/F1 if using internal batteries.
 - b) If using external batteries close the battery fuses/isolator on the associated battery cabinet/rack.
4. Simultaneously press the two ON/OFF push buttons on the UPS control panel.
 - a) The UPS will run through an automated start-up sequence accompanied by the following indications:
 - LINE 2 LED lights red then changes to green.
 - INVERTER LED lights green.
 - BATTERY LED lights green (constant).
 - b) LCD displays the LOAD PROTECTED message.

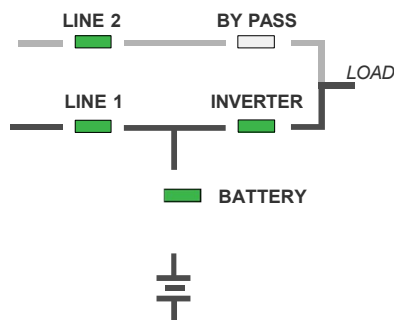

LED	Colour
LINE 1	Green
LINE 2	Green
BY PASS	Off
INVERTER	Green
BATTERY	Green

5. The UPS module is now On Line and connected to the parallel system.

Module shut-down:

Use this procedure to power down a single module in a redundant module system.

1. Simultaneously press the two ON/OFF buttons on the UPS control panel.
 - a) The LED display will give the following indications:

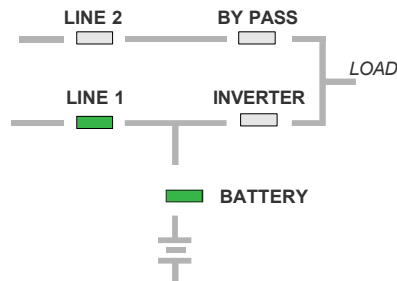

LED	Colour
LINE 1	Green
LINE 2	Off
BY PASS	Off
INVERTER	Off
BATTERY	Green

2. Open the Parallel Isolator switch IA2.
3. In the UPS Cabinet, open the Input supply and Bypass supply fused isolators FA1 and FA2.
4. Open the battery fuse/isolator.
 - a) Open FA3/F1 if using internal batteries.
 - b) If using external batteries open the battery fuses/isolator on the associated battery cabinet/rack.
5. Open the UPS input supply isolator and UPS output isolator on the LV Switchboard.
6. The UPS module is now totally shut-down.

5. Maintenance

5.1 Introduction



WARNING: All the operations described in this chapter must be performed by authorised electricians or otherwise qualified personnel.

5.2 System calibration

To ensure optimum UPS operation and continuous, efficient protection of the connected load, it is recommended that the system's operating parameters are checked every six months and recalibrated where necessary.

The batteries should also be checked every six months, depending on the ambient temperature.

5.3 User responsibilities

The UPS equipment should be inspected daily to ensure that the environment in which it is operating is kept cool and dust free at all times, and that the operating temperature and humidity is within the limits given in the specifications chapter of this manual. The UPS equipment should also be maintained in accordance with the manufacturer's recommendation and any life limited components replaced at the required intervals and critical updates are performed. Any active alarm or status indication that suggests that the UPS is not functioning correctly should be dealt with immediately by referring to the troubleshooting chapter of this manual or contacting the manufacturer's service desk..

5.4 Routine maintenance

It is essential that the UPS system and batteries receive regular preventative maintenance inspection to maximise both the useful working life and the reliability of the UPS system. When the UPS is commissioned, the commissioning field service engineer will attach a service record book to the front of the UPS which will be used to log the full service history of the UPS.

Preventative maintenance inspections involve working inside the UPS which contains hazardous AC and DC voltages.



WARNING: Only Rehiko trained and authorised field service engineers are fully aware of all of the hazardous areas within the UPS.

During a preventative maintenance inspection the field service engineer will carry out the following checks:

• Site/environment conditions	• Integrity of electrical installation
• Cooling airflow	• Rectifier operation and calibration
• Inverter operation and calibration	• Static switch operation
• Battery status	• Load characteristics
• Integrity of alarm and monitoring systems	• Operation of all installed options
• Condition of life limited components	• Manufacturer recommended updates

Preventative maintenance inspections form an integral part of all Extended Warranty Agreements (maintenance contracts) offered by Rehiko.

For further details on Extended Warranty Agreements see Section 2 of this manual.

5.5 Battery Testing

The battery test takes approximately 3 minutes and should be performed only if:

- There are no alarm conditions
- The battery is fully charged

The battery test procedure can be performed from the UPS front panel and can be carried out independently of the operating mode (Off-line or On-line) and whether or not the load is connected.

6. Troubleshooting

6.1 Alarms

In the event of an alarm condition the red ALARMLED-indicator will illuminate on the operator control panel and the audible alarm will sound.

In this case proceed as follows:

1. Silence the audible alarm by pressing the RESETbutton.
2. Identify the cause of the alarm condition by viewing the events register in the main menu (*See paragraph 4.3.3*).
3. In case of doubt please contact Rehlko

Fault identification and rectification information is given on the following pages.

IMPORTANT NOTE

Certain alarm conditions may 'latch-on' even after the cause of the alarm is no longer present. For example, if there is a brief mains failure during unattended operation the MAINSRECTFAULTalarm will activate and it may still indicate a fault condition even after the mains supply has returned to normal.

If any of the following alarms appear, the first action to take is to attempt to RESET it.

- MAINSRECTFAULT
- MAINSBYPFAULT
- BYPASSISOK
- BYPASSISNOTOK

If the alarm resets then it was probably caused by a transient condition and is no longer present; the UPS responded correctly and no further action is required. However, if it is not possible to reset the alarm, investigative action is necessary which may require assistance from the UPS Service department.

6.2 Menu, Commands, Event Log, Measurements,

A detailed description of the Menu, Commands, Event Log and Measurements that can be operated and displayed on the LCD can be found in Section 4.

6.2.1 Event Log Screen

DESCRIPTION	LCD-DISPLAY
1. Logging Control	01 05-10-00 14-38-56 LOAD TO INV.
2. A log of the last 99 events is stored in the Power Management Display.	02 05-10-00 14-38-59 LOAD TO BYP.
3. All events and alarms are indicated with their date and time of occurrence.	03 05-10-00 14-39-14 LOAD OFF

As you step through the event memory, make a separate note of each alarm condition as this will assist in the identification of any problems.

6.2.2 Fault Identification and Rectification Messages and Alarms

The major alarm conditions that will be encountered are:

Alarm Condition	Meaning	Suggested Solution
UPS FAULT	There is a fault in the UPS and therefore normal operation cannot be guaranteed	Call the authorised service centre for assistance
MAINS BYP/RECT FAULT	Mains power supply is outside prescribed tolerance	The input power to UPS is too low, too high, or missing. If site power appears to be OK, check the input circuit breakers etc. supplying the UPS
OUTPUT SHORT	There is a short circuit at the output of UPS (on load side)	Check all output connections and repair as required.
OVERLOAD	Load exceeds the UPS rated power	Identify which piece of equipment is causing the overload and remove it from the UPS. Do not connect laser printers, photocopiers, electric heaters, kettles etc. to the UPS
OVERTEMPERATURE	UPS temperature has exceeded the allowed value	Check the ambient temperature of the UPS is less than 30° C. If the ambient temperature is normal call the authorised service centre for assistance.
BATTERY CHARGER OFF	The attached battery and the battery charger setup do not correspond or battery charger fault	Call the authorised service centre for assistance.
INVERTER FAULT	Inverter is faulty	Call the authorised service centre for assistance.
SYNCHRON FAULT	The inverter and mains are not synchronised.	The frequency of the input voltage to the UPS is outside operational limits and the UPS static bypass has been temporarily disabled. Check that generator is connected
BATTERY IN DISCHARGE	Battery is near end of autonomy	Shutdown load connected to UPS before the UPS switches itself off to protect its batteries
MANUAL BYP IS CLOSED	Maintenance Bypass closed. Load supplied by mains	This alarm is only displayed if the UPS is on Maintenance Bypass

6.3 Contacting Service

Rehiko has a service department dedicated to providing routine maintenance and emergency service cover for your UPS.

We recommend that your UPS is protected by an Extended Warranty Agreement. These agreements assist us in caring for your UPS correctly, ensuring that it is well maintained and attended to promptly should any problems occur.

If you have any queries regarding your UPS please contact us.

UK

www.ups.rehiko.co.uk

ukservice.ups@rehiko.com

uktechnicalsupport.ups@rehiko.com

uksales.ups@rehiko.com

ukservicesales.ups@rehiko.com

Rehiko web site

Service department – booking service, fault reporting etc.

Technical queries

Hardware sales

Extended warranty agreements etc

IRELAND

www.ups.rehiko.ie

ieinfo.ups@rehiko.com

Rehiko web site

Service department, technical queries, hardware sales and extended warranty agreements

SINGAPORE

www.ups.rehiko.sg

salesups.sg@rehiko.com

serviceups.sg@rehiko.com

Rehiko web site

Hardware sales

Contract customer support, maintenance contracts renewals

7. Options

7.1 Introduction

The Rehlko PW 5000/TP UPS has the following available options:

- Remote Emergency Stop facilities
- Generator On facilities
- Temperature sensor for temperature-dependant battery charging
- Software for automatic shutdown and monitoring
- SNMP Card for network management and remote monitoring
- Modem/Ethernet interface for PowerREPORTER™ management software

7.2 Remote Emergency Stop facilities

The remote emergency stop facility comprises a normally-closed contact, connected to terminal port X1/7 and X1/8 on the communications board, which opens to operate the emergency stop sequence.

Note: Usually the remote emergency stop function is disabled, and it should be activated by a hardware code on the SETUP SERVICE menu. Please contact your distributor to enable this operation.

To allow removal, maintenance or testing of any remote emergency stop facility without disturbing the normal operation of the UPS, it is recommended that a terminal block, with linking facilities, is installed between the UPS and the remote emergency stop button.

1. Use a screened cable with 1 pair (section of wires 0.6 mm²) and maximum length of 100 m.
2. Connect the cable as shown in Figure 7.1.

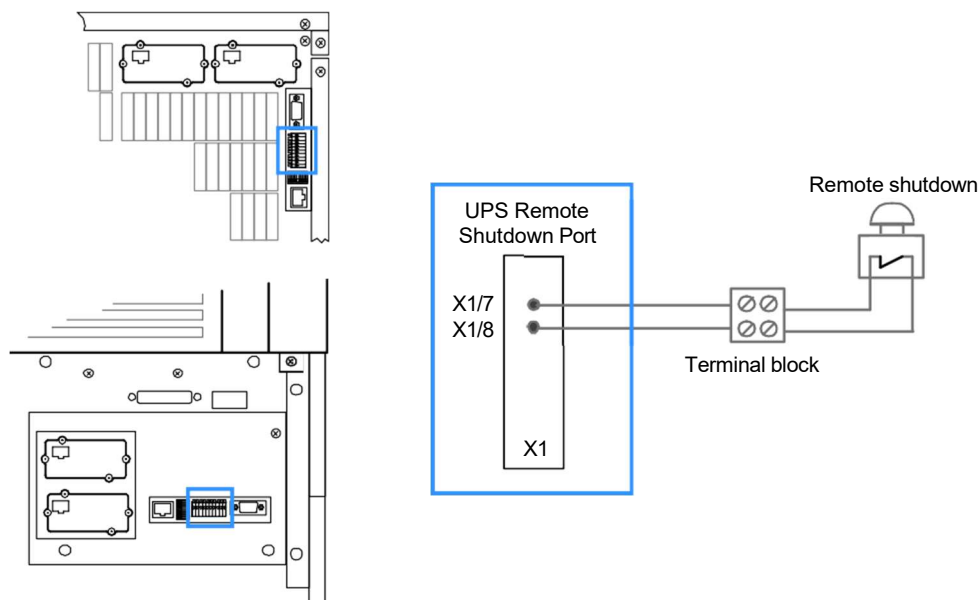

Figure 7.1 Remote Emergency Stop cabling

7.3 Generator ON facilities

The generator ON facility must use a normally-open contact which closes to indicate that a generator is running and supplying the UPS input power.

When used, this facility inhibits the operation of the battery charger and/or static bypass while the UPS is being supplied from a standby generator. See “Set-up User menu screen” in section 4.3.7.

1. Use a screened cable with 1 pair (section of wires 0.6 mm²) and maximum length of 100 m.
2. Connect the cable as shown in Figure 7.2.

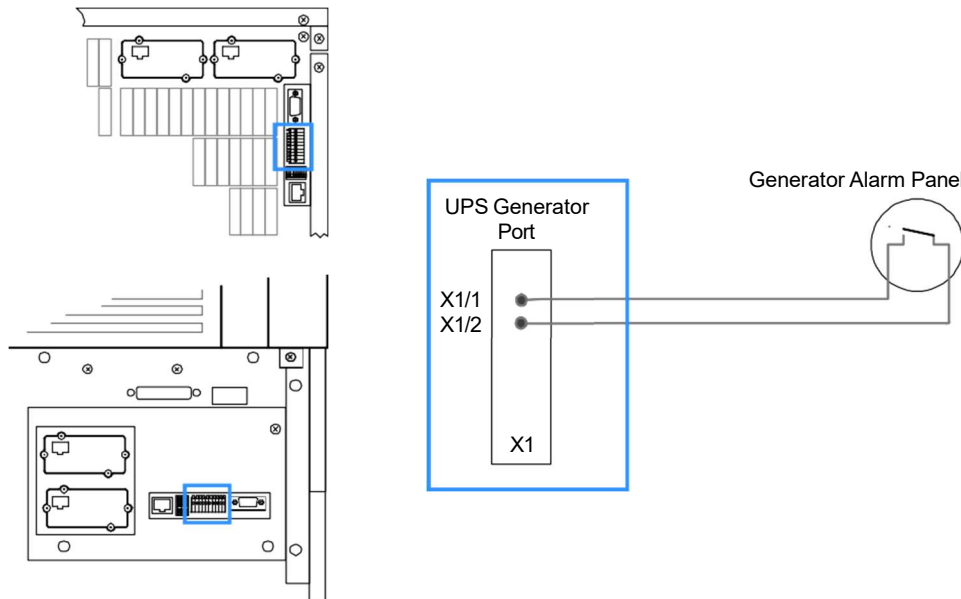
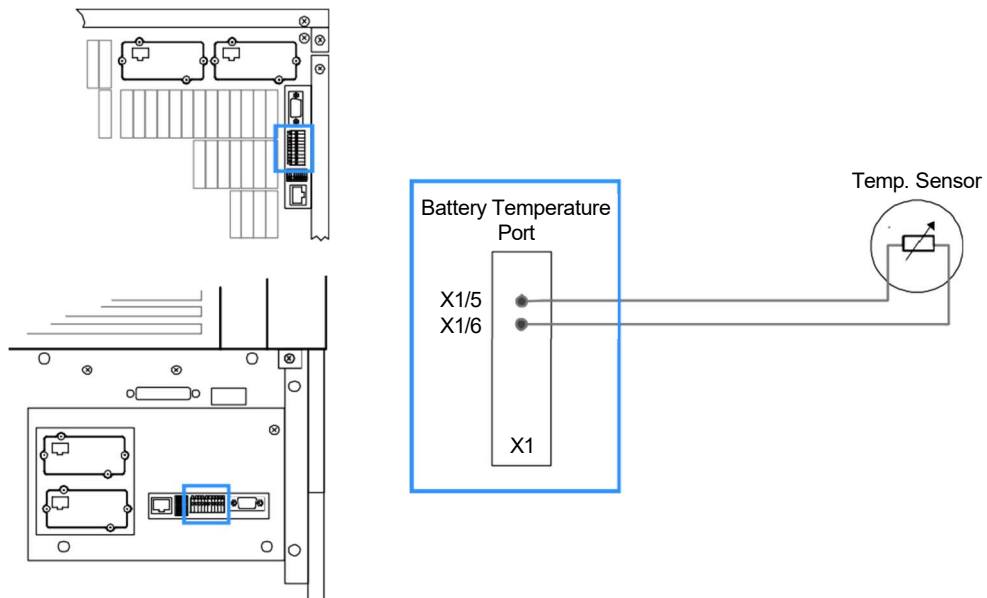

Figure 7.2 Generator ON Connection

7.4 Temperature sensor for temperature-dependent battery charging

A temperature sensor can be used to vary the battery charging voltage depending upon the battery temperature.



7.5 UPS Monitoring and automated control software

7.5.1 The importance of UPS management

The utility supply is inevitably unreliable every now and then; and assuring continuous power to all the facilities connected to it can be a difficult task. The situation is further complicated if worldwide systems are managed via a Local or Wide Area Network (LAN/WAN).

However, by interfacing the PW 5000/TP UPS system with purpose-designed network management tools, a System Administrator can take measures to back-up data and prevent system errors in the event of a long utility supply outage.

Suitable UPS management software can enable a System Administrator to monitor all attached networks from a central point and identify bottlenecks at an early stage but, in spite of extensive system monitoring, serious damage can still occur if an administrator fails to intervene in a timely manner. It is therefore important that, when appropriate, the installed UPS software can react automatically to shut down the supplied system in a safe and controlled manner.

Rehiko considers it important to have a complete solution for its UPS systems and offers its customers a number of remote control and monitoring tools to provide optimum protection.

Three (optional) monitoring systems are available for use with the Rehiko PW 5000/TP UPS system:

- SNMP – can be used for monitoring and controlled UPS shutdown
- WAVEMON – can be used for monitoring and controlled UPS shutdown
- PowerREPORTER – can be used to automatically email details of monitored parameters and alarm events to Rehiko for appropriate service support response

7.5.2 SNMP monitoring software

The SNMP adapter described above requires a PC with terminal connections and, for normal operation, at least one Ethernet network connection. It also requires that the network operating system in use is SNMP-compatible.

7.5.3 WAVEMON UPS monitoring and control software

WAVEMON is a bespoke software package, designed to operate in conjunction with many of the systems supplied by Rehiko, which features both UPS monitoring and automatic UPS/server shutdown facilities.

The package is installed on a local PC and communicates with the UPS via USB or an RS-232 serial cable so does not require the purchase of an SNMP card or adapter.

The main features of WAVEMON are:

- on-screen autonomy time/battery time countdown
- on-screen server log-off and shutdown procedure
- time and date stamp event log
- extensive logging of all UPS activity and power quality data
- permits alarm warnings to be monitored remotely via email
- scheduled UPS service mode and other systems status
- graphical user interface for Windows-compatible platforms
- automatic unattended local shutdown
- special modules for MS-Office software to close and save open documents
- compatible with all optional modules like UPSDIALER, SNMP adaptors, temperature sensors, etc.

Functional description

WAVEMON is a client/server software application designed for networks and local workstations. In general, it consists of two parts: the server module of the UPS management software is *UPSMAN*, which communicates with the UPS via an RS232/USB interface. Running as a background application, *UPSMAN* collects and interprets the messages received from the UPS and places them at the disposal of the client module *UPSMON*, as well as any connected SNMP-based instrumentation and control system.

If *UPSMAN* detects voltage variations or a power failure, it can execute various 'system event' routines, by means of which, for example, the server is switched off or a warning/alarm is sent to the connected users. These 'system event' routines are a part of the management software and can be configured in to suit local application requirements.

The PW 5000/TP UPS software unit can be integrated into a network in two ways:

1. By the server which is supplied by the UPS itself and has been integrated into the network.

In most cases this server is used as a sub-agent and you only need the WAVEMON software (without an SNMP adapter). You will also need to establish an RS232/USB connection between the UPS and computer/server.

2. By the use of an SNMP card/adaptor

An SNMP card/adaptor is to be preferred in order to integrate the UPS into the network. In this case up to 50 computers can be shut down in one RCCMD environment. RCCMD (remote console command) is an additional software module that is used in order to execute a command (typically a shutdown command) in a remote system.

Licensing

A licence is issued with every software serial number for use of what is known as the 'UPS service' on a single server in connection with one UPS and an unlimited number of connected WINDOWS workstations. For operation with two or more servers, a further licence is required for each additional server. In this case it is of no importance whether the UPS service on these servers is active or whether the server was stopped by a remote UPS service. The same applies to the use of RCCMD with the 'remote send/receive' modules for 'multi-server shutdown' under NT, UNIX and other operating systems.

The service programs are generally supplied as single licences. In order to use a single CD-ROM for several 'multi-server shut-down' units you must acquire additional licence codes.

RCCMD Server shutdown

In order that remote shutdown of servers can take place, initiated by the SNMP card or WAVEMON software, further licenses must be purchased. The license is for the RCCMD client (or listening) software that resides in each target server.

7.5.4 PowerREPORTER™ management software

PowerREPORTER is a remote monitoring and management service which provides peace-of-mind protection by offering a continuous (24/7/365) watch over mission-critical facilities. Continuous monitoring is an affordable insurance policy to detect issues and provide an early warning before they develop into a crisis.

The main features and benefits offered by PowerREPORTER are:

- real time alarm or critical event email notification sent directly to Rehiko service centre
- acquisition of key performance data and productivity information to allow a better understanding of the UPS system performance and quickly troubleshoot downtime events
- improved service level. Combined with a service contract, PowerREPORTER ensures an engineer can determine if site attendance is necessary and bring relevant spare parts
- Monthly status report detailing trends and alarms

An optional battery analysis and care service; PowerNSURE - measures battery voltage, temperature, impedance and prolongs battery service life through the application of battery charge equalization.

Functional description

PowerREPORTER communicates constantly with your UPS system to automatically detect any error or alarm messages. If it encounters an incident, PowerREPORTER will automatically transmit a status message, via email, to the Rehlko service centre providing details relating to the identified fault, a snapshot of the UPS performance parameters and a device identification string.

The email automatically alerts the service centre personnel who then remotely diagnose the UPS incident and liaise with the company's field service team so that they can reach the facility with appropriate spare parts within the contracted service agreement time-frame.

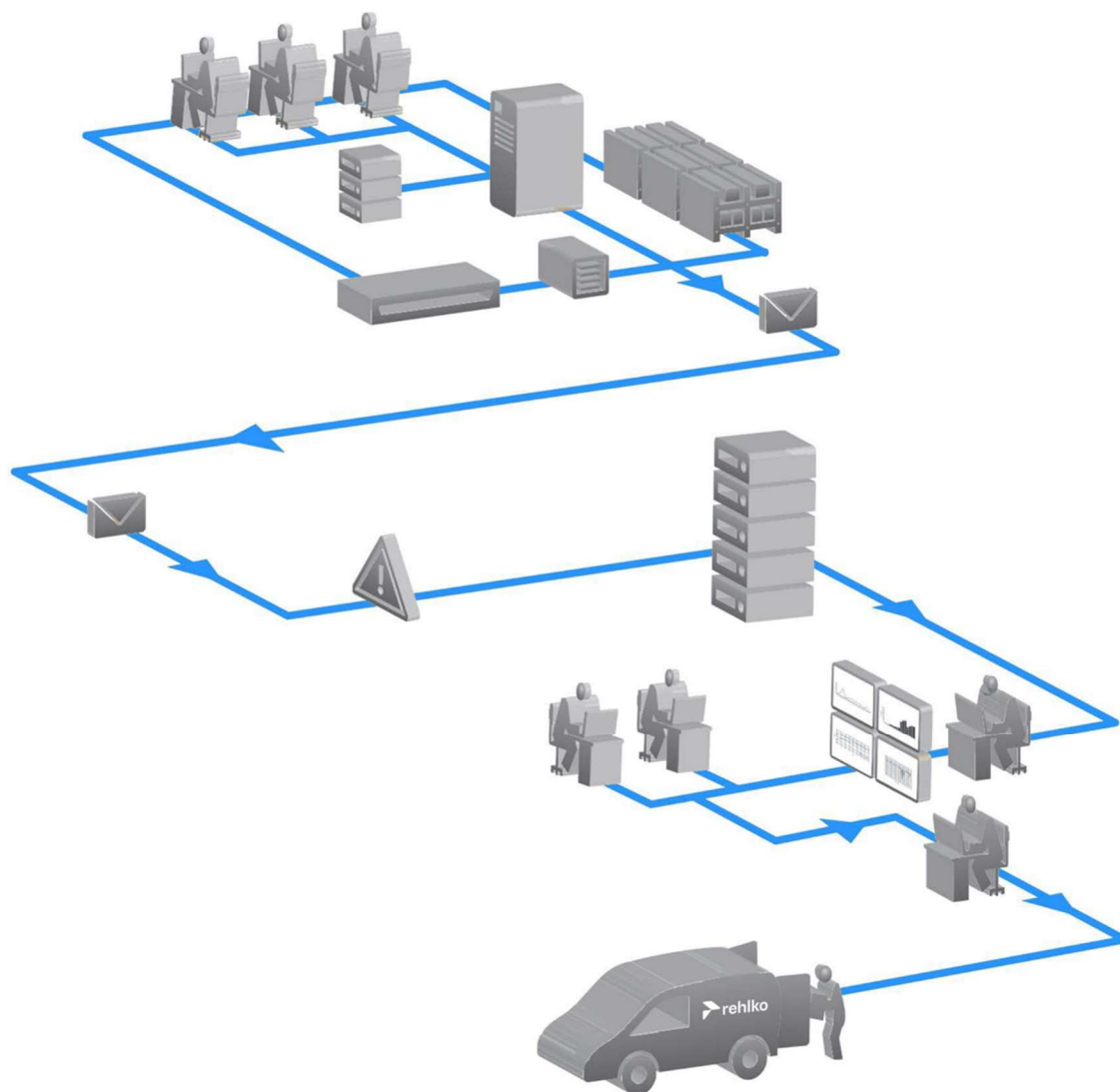

8. Specifications

8.1 Mechanical

Cabinet A

		Module Rating (kVA)		
		10	15	20
WITHOUT BATTERY ENCLOSURE Dimensions (WxHxD)	mm	345 x 720 x 710		
Weight (without battery)	kg	60	62	64
Weight (with 48x7Ah battery)	kg	180	182	184
Weight (with standard packaging)	kg	+4		
Colour		Black (RAL 9005)		

Cabinet B

		Module Rating (kVA)			
		10	15	20	25
WITHOUT BATTERY ENCLOSURE Dimensions (WxHxD)	mm	345 x 1045 x 710			
Weight (without battery)	kg	88	90	92	94
Weight (with 96x7Ah battery)	kg	328	330	332	334
Weight (with standard packaging)	kg	+5			
Colour		Black (RAL 9005)			

Cabinet C

		Module Rating (kVA)			
		25	30	40	50
WITHOUT BATTERY ENCLOSURE Dimensions (WxHxD)	mm	440 x 1420 x 910			
Weight (without battery)	kg	(9Ah/ 28Ah) 151/135	(9Ah/28Ah) 160/145	(9Ah/ 28Ah) 165/150	(9Ah/28Ah) 170/155
Weight (with 144x7/9Ah battery)	kg	540	550	555	560
Weight (with 48x28Ah battery)	kg	605	615	620	625
Weight (with standard packaging)	kg	+5			
Colour		Black (RAL 9005)			

8.2 Input Characteristics

		Module Rating (kVA)						
		10	15	20	25	30	40	50
Nominal Input Voltage	V	3x380/220V+N, 3x400V/230V+N, 3x415/240V+N						
Input Voltage Tolerance (ref to 3x400/230V) for Loads in %:	V	(-23%/+15%) 3x308/177 V to 3x460/264 V for <100% load (-30%/+15%) 3x280/161 V to 3x460/264 V for <80% load (-40%/+15%) 3x240/138 V to 3x460/264 V for <60% load						
Input Frequency	Hz	35 - 70						
Input Power Factor		PF=0.99 @ 100% load						
Oversoltage Category		II (2500Vpk)						
Backfeed Protection		Optional						
Inrush Current	A	max. In						
Input Distortion THDi		THDi < 3.0% @ 100% load (Input THDv <2%; tolerance +-0.3%)						
Max. Input Power with rated output power and charged battery (output pf = 0.9)	kW	9.6	14.4	19.1	23.9	28.7	38.3	47.9
Max. Input Current with rated output power and charged battery (output pf = 0.9)	A	13.9	20.8	27.8	34.7	41.6	55.5	69.4
Max. Input Power with rated output power and discharged battery (output pf = 0.9)	kW	10.5	15.7	21	26.2	31.4	41.9	52.4
Max. Input Current with rated output power and discharged battery (output pf = 0.9)	A	15.2	22.8	30.4	37.9	45.5	60.7	75.9

8.3 Output Characteristics

		Module Rating (kVA)						
		10	15	20	25	30	40	50
Output Rated Power	kVA	10	15	20	25	30	40	50
Output Rate Current (In) @ rated power in kVA and @ 400 V	A	14.4	21.7	28.9	36.1	43.3	57.7	72.2
Output Rated Power (0.9 pf)	kW	9	13.5	18	22.5	27	36	45
Output Rate Current (In) @ rated power in kW and @ 400 V	A	13	19.5	26	32.5	39	52	65
Output Rated Voltage	V	3x380/220V or 3x400/230V or 3x415/240V						
Output Voltage Stability	%	Static: < ±1% Dynamic (Step load 0%-100% or 100%-0%) < ±4%						
Output Voltage Distortion	%	With Linear Load < 2% With Non-linear Load (EN62040-3:2001) < 4%						
Output Frequency	Hz	50 Hz or 60 Hz						
Output Frequency Tolerance	Deg	Synchronized with mains < ±2% (selectable for bypass operation) or < ±4% Free running ±0.1%						
Bypass operation		At Nominal Input voltage of 3x400 V ±15%, or 196 V to 264 V ph-N						
Permissible Unbalanced Load (All 3 phases regulated independently)	%	100%						
Phase Angle Tolerance (With 100% Unbalanced load)	Deg.	±0 deg						
Overload Capability on Inverter	%	110% load 5 min. 125% load 20 Sec.				110% load 10 min. 125% load 1 Min		
Output short capability (RMS)	A	Inverter: up to 3 x In during 40 ms Bypass: 10 x In during 10 ms						
Crest - Factor		3: 1						

8.4 Battery Characteristics

	Module Rating (kVA)											
	10		15		20		25		30	40	50	
Cabinet Type	A	B	A	B	A	B	B	C	C	C	C	
Min/Max Number of 12V Battery Blocks per string	24-50*		30-50*		28-50*		28-50*		26-50*		16-50*	
Maximum Battery Charger Current (Amps)	4A								6A			
Battery Charging Curve	Ripple free; IU (DIN 41773)											
Temperature compensation ready	Standard (temp. sensor optional)											
Battery Test	Automatic and periodically (adjustable)											
Battery Type	Maintenance free VRLA or NiCd											

* Depending on the effective load in kW used by the system

8.5 Environmental

		Module Rating (kVA)						
		10	15	20	25	30	40	50
Audible Noise with 100% / 50% Load	dBA	55/49	55/49	57/49	57/49	58/50	59/50	59/50
Operation temperature	°C	0 - 40						
Temperature for Batteries (recommended)	°C	20						
Storage Temperature	°C	Between -25 and +70						
Battery Storage Time		Max. 6 months						
Max. altitude (above sea level)	m	1000m (3300ft) without de-rating						
De-rating factor for use at altitudes above 1000m sea level according (IEC 62040-3)		ALL MODULES						
		Metres above sea level (m / ft)				De-Rating Factor for Power		
		1500 / 4850				0.95		
		2000 / 6600				0.91		
		2500 / 8250				0.86		
		3000 / 9900				0.82		
Relative Air-humidity		Max. 95% (non-condensing)						
Positional Clearances		Front: A minimum of 900mm should be allowed for free passage. Side: 600mm left and right side access is required for service. Rear: A minimum of 200mm is required for cooling air circulation and the unit should be cabled such that it can be pulled forward to allow 600mm rear clearance for service/maintenance.						
Accessibility (Operator)		10kVA – 25kVA in type A or B cabinets require front/rear access 25kVA – 40kVA in type C cabinets require front access only						
Input and Output Power Cabling		10kVA – 25kVA in type A or B cabinets are cabled at the rear 25kVA – 40kVA in type C cabinets are cabled at the rear						
Efficiency AC-AC up to (at pf=1.0) (depending on UPS power)	Load: Efficiency:	100% 75% 50% 25% 95.5% 95.5% 95% 94.5%						
Eco-Mode efficiency at 100% load	%	98%						
Pollution Degree		2						

8.6 Heat Dissipation With Non-Linear Loads

		10kVA	15kVA	20kVA	25kVA	30kVA	40kVA	50kVA
Heat Dissipation with 100% Non-linear Load per range (EN 62040-3)	W	600	900	1100	1400	1700	2300	2900
Heat Dissipation with 100% Non-linear Load per range (EN 62040-3)	BTU/h	2048	3072	3754	4778	5802	7850	9898
Airflow (25°C - 30°C) with 100% Non-linear Load per range (EN 62040-3)	m³/h	150	150	150	150	570	570	570
Heat Dissipation without load	W	120	150	150	170	250	300	350

8.7 Standards

	Module Rating (kVA)						
	10	15	20	25	30	40	50
Safety	IEC/EN 62040-1-1:2003, IEC/EN 60950-1:2001/A11:2004						
Electromagnetic Compatibility	IEC/EN 62040-2:2005, IEC/EN61000-3-2:2000, IEC/EN61000-6-2:2001,						
EMC Classes C2 domestic or industrial In < 16A C3 industrial In >16A	C2	C3					
Performance	IEC/EN62040-3:2001						
Product certification	CE, UKCA						
Degree of protection	IP 20						

8.8 Communication Options

	All Modules
Power Management Display (PMD)	LCD display
RS232 on Sub-D9 port	For monitoring and integration in network management
Customer Interfaces: Inputs (DRY PORTS)	1 Remote Shut down [EMERGENCY OFF (Normally closed)] 1 GEN-ON (Normally open) 1 Programmable Customer's Inputs (Normally open) 1 Temp. Sensor for Battery Control 1 12Vdc source (max. 250mA)
RJ45 port	For multidrop purpose (optional)
Relay card +USB Including: Customer Interfaces: Outputs (DRY PORTS)	Common Alarm Load on Bypass Battery Low Load on Inverter Mains Failure
RS232 on USB Port	For remote signalling and automatic computer shutdown
SNMP Card (slot already included)	For monitoring and integration in network management

8.9 Fuses & Cables Quick Reference

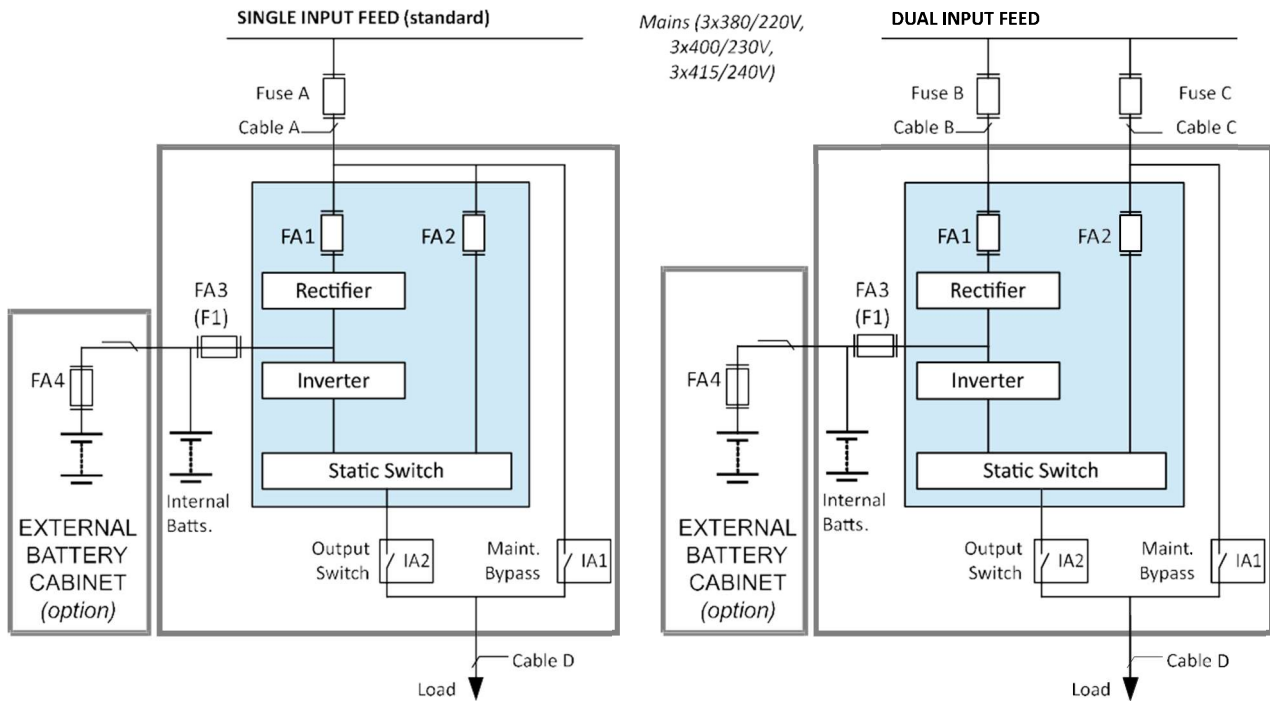

SINGLE INPUT FEED

Power (kVA)	Fuse A (Agl/CB) (A)	Cable A (mm ²)	Cable D (mm ²)
10	3 x 20	5 x 2.5	5 x 2.5
15	3 x 32	5 x 4.0	5 x 4.0
20	3 x 40	5 x 6.0	5 x 6.0
25	3 x 40	5 x 6.0	5 x 6.0
30	3 x 63	5 x 10	5 x 10
40	3 x 80	5 x 25	5 x 25
50	3 x 80	5 x 25	5 x 25

DUAL INPUT FEED

Power (kVA)	Fuse B (Agl/CB) (A)	Cable B (mm ²)	Fuse C (Agl/CB) (A)	Cable C (mm ²)	Cable D (mm ²)
10	3 x 20	5 x 2.5	3 x 20	5 x 2.5	5 x 2.5
15	3 x 32	5 x 4.0	3 x 32	5 x 4.0	5 x 4.0
20	3 x 40	5 x 6.0	3 x 40	5 x 6.0	5 x 6.0
25	3 x 40	5 x 6.0	3 x 40	5 x 6.0	5 x 6.0
30	3 x 63	5 x 10	3 x 63	5 x 10	5 x 10
40	3 x 80	5 x 25	3 x 80	5 x 25	5 x 25
50	3 x 80	5 x 25	3 x 80	5 x 25	5 x 25

1. Fuse and Cable recommendations to IEC 60950-1:2001
2. The fuse and cable rating details in the above tables are a recommendation only.
3. The UPS must be installed to prescribed IEC or local regulations (e.g. BS7671).
4. External DC Cables and Battery fuses are bespoke to the installation.