



REHLKO *MF* Series

Distributed Bypass

Modular high power three-phase uninterruptible power supply

(250 – 1500 kVA/kW)

Scalable to 6000 kVA/kW

Technical Specification

Document Control

ISSUE	DATE	REVISION SUMMARY
TS_765_01	20/11/2023	Rebranded International version
TS_765_02	13/05/2024	Input and Output currents changed to 'per module'
TS_765_03	18/03/2025	Standards Added
TS_765_04	04/08/2025	Battery charging ratings updated
TS_765_05	01/10/2025	Addition of 500 and 750kva, contents & minor corrections
TS_765_06	06/05/2026	Rebranded to Rehlko

Useful Contacts

UK

www.ups.rehlko.co.uk

ukservice.ups@rehlko.com

uktechnicalsupport.ups@rehlko.com

uksales.ups@rehlko.com

ukservicesales.ups@rehlko.com

Rehlko web site

Service department – booking service, fault reporting etc.

Technical queries

Hardware sales

Extended warranty agreements etc

IRELAND

www.ups.rehlko.ie

ieinfo.ups@rehlko.com

Rehlko web site

Service department, technical queries, hardware sales and extended warranty agreements

SINGAPORE

www.ups.rehlko.sg

salesups.sg@rehlko.com

serviceups.sg@rehlko.com

Rehlko web site

Hardware sales

Contract customer support, maintenance contracts renewals

All product, product specifications and data are subject to change without notice to improve reliability, function, design or otherwise. Rehlko has taken every precaution to produce an accurate, complete and easy to understand specification document and will assume no responsibility nor liability for direct, indirect or accidental personal or material damage due to any misinterpretation of, or accidental errors, in this manual.

© 2026 Rehlko

This document may not be copied or reproduced without written permission of Rehlko.

Contents

REHLKO MF SERIES DESCRIPTION	2
Model Range	2
Key Features	3
MF SERIES WITH DISTRIBUTED BYPASS	5
Mechanical Characteristics MF Series with Distributed Bypass	6
Rehiko MF1500 DPA – 500 kVA Frame	6
Rehiko MF1500 DPA – 750 kVA Frame	6
Rehiko MF1500 DPA – 1000 kVA Frame	7
Rehiko MF1500 DPA – 1250 kVA Frame	7
Rehiko MF1500 DPA – 1500 kVA Frame	8
Rehiko MF1500 DPA – 250 kVA Power Module	9
GENERAL SPECIFICATIONS	10
ELECTRICAL CHARACTERISTICS	11
INPUT CHARACTERISTICS	11
EFFICIENCY CHARACTERISTICS	12
OUTPUT CHARACTERISTICS	13
STATIC BYPASS CHARACTERISTICS	14
BATTERY AND ENERGY STORAGE CHARACTERISTICS	14
POWER EXCHANGER	18
REMOTE CONTROL AND MONITORING	20
UPS CONTROL AND MONITORING	21
System Control Panel	21
Module Control Panel	21
INSTALLATION AND PLANNING	22
UPS FOOTPRINT AND CLEARANCES	23
CABLE PLANNING	24
Single Input Feed with Separate Battery Connection	25
Single Input Feed Common Battery Connection	26
Heat Dissipation	27
STANDARD FEATURES	27
Cold Start	27
UPS power walk-in when transferring back from batteries to utility	27
Synchronization Feature	28
Castell Key Interlock	28
External Maintenance Bypass Switch and Output Switch connections	28

REHLKO MF SERIES DESCRIPTION

Three phase double conversion uninterruptible power supply for critical environments that have high power demands. The UPS is specially designed for modern data storage infrastructures such as enterprises, colocation, cloud, internet, media, and telecommunications data centres.

The Rehiko MF Series provides a continuous flow of clean, sustainable power. The UPS is based on 250 kW power modules with scalable power up to 2000 kW or 1750 N+1 for redundancy in a single system and up to 4 units can be connected to provide a total of 6 MW capacity.

The Rehiko MF Series UPS incorporates the latest technological developments in power engineering. Representing a completely new generation of high power three phase UPS systems, its advanced double conversion VFI (Voltage and Frequency Independent) topology is optimised to provide the highest availability and energy efficiency for a UPS system of this type. The Rehiko MF Series UPS is compliant with the IEC 62040-3 (VFI-SS-111) standards.

Rehiko Ltd. specialises in the installation and maintenance of Uninterruptible Power Systems, emergency lighting inverters and standby generators. This powerful UPS is just one example of our wide range of state-of-the-art power protection devices that will provide your critical equipment with a steady and reliable power supply for many years.

Model Range

The Rehiko MF Series is a truly expandable system, based on a number of plug-in 250 kW UPS modules installed in a purpose-designed cabinet. Up to six 250 kW modules in the 1500 kW frame, up to five 250 kW modules in the 1250 kW Frame, up to four 250 kW modules in the 1000 kW Frame, up to three 250 kW modules in the 750 kW Frame and up to two 250 kW modules can be fitted in the 500 kW Frame. Thanks to the advanced Rehiko MF Series system design, if a cabinet is not fully populated it is possible to add further UPS modules to increase the system capacity without having to power-down the system or in any way disrupt the load. Using the 1500 kW frame as an example, if a system is initially purchased with only two UPS modules fitted, an additional four modules can be installed later as and when required. Depending on the system redundancy and existing load demand, this 'hot-swappable' design also allows individual modules to be exchanged while the equipment remains fully operational without having to transfer the load to the unprotected bypass supply.

Further expansion is made possible by connecting up to four UPS cabinets in parallel to provide a total system output of up to 6.0 MW.



Key Features

Uninterruptible power – power capacity and redundancy on demand



Up to 1500 kW power protection in a single UPS by paralleling power modules of 250 kW. Power modules can be slid in, adding power capacity, or providing internal redundancy (N+1).



Readiness for parallel redundant system configurations (2N, 2(N+1), 3N/2) securing uptime and reliability

Maximized availability and resiliency



Proven technology and maximized availability based on power modules of 250 kW that include all necessary functional parts, such as rectifier, inverter, battery converter, static bypass, and back-feed protection. The UPS architecture provides fully redundant critical components and shares the load equally among the power modules.



Concurrently maintainable power modules for continuous uptime. The power module is online swappable while the load is secured in double conversion mode. Insertion or removal of the power module is smooth and simple thanks to wheels and guide rails. Further, the power module plug-in concept supports easy and safe power connection, thus eliminating electrical hazards.



Fail-safe startup of the system without human intervention by testing of power modules before applying to the critical load.



Fault-tolerant UPS operation. If one power module fails, the others take up the load - without impacting the power supply.



Minimized energy losses, heat dissipation and electricity cost while the critical load is protected by the UPS in double conversion or ECO modes. The UPS achieves an efficiency of up to 97.4% in double conversion mode and 99 % in ECO mode.



Flexible operation optimizes UPS efficiency and reduces power loss when the load is low compared to the UPS total capacity. Rehiko Xtra VFI mode can improve system efficiency by optimizing the number of power modules used in double conversion mode to feed the load.



Simply and safe installation. The UPS is provided with pre-engineered power frames consisting of metal busbars – which eliminate wiring entirely – and slide-in power modules with safe, plug-in connections that remove any hazard.



Ease to operate and manage real-time monitoring is provided by the local system display or in the control room via the web application.



Design life of up to 15 years reduces the cost of systems replacements over the infrastructure lifespan



Control and monitoring features, I/O dry ports, dry inputs for remote shutdown, generator, operational and external switchgear, castell interlock function, preconfigured battery temperature sensor input



Power Exchanger - Grid-support option and Demand response functionality is an energy management function available on the MF Series family enabling the UPS to interact with the grid and supply (upon external request) ancillary grid services.



AI Load profile optimization: MF Series UPS family has been assessed and confronted with design developing an **outstanding proven AI Ready performance.**



Through this **Frequency Regulation Function (FRF)** UPS can reduce/increase the input power flowing from grid to the UPS or even to reverse the flow and inject power back into the grid (back-feed), while maintaining constant the output power.



Sustainable Self-Test functionalities, even with NO-LOAD situation. UPS modules can be powered from input grid supply or from Battery storage energy to execute the full-load self-test. This functionality support commissioning, site implementation and thermal on-site losses simulation test for cooling systems.



Flexible to integrate several back-up power sources, including traditional valve-regulated lead acid (VRLA), Lithium-Ion solutions and new energy storage chemistries, as Nickel-Zinc (NiZn) ready.

MF SERIES WITH DISTRIBUTED BYPASS

The MF Series double conversion online modular UPS with distributed bypass benefits from all the advantages of DPA Technology. The key features of this UPS are:

- Distributed static bypass switches
- Each UPS module can operate autonomously
- Redundant critical components and paths serving the load; no single points of failure
- UPS modules can be online-swapped without impacting the load
- Redundant power configuration (N+1) with common or separate batteries
- Smart load sharing between the active UPS modules
- Continuous and redundant control and monitoring on module and system level

Power capacity and redundancy can be tailored to suit with up to 6000 kW power protection available in a single UPS system by paralleling power modules of 250 kW. Additional power modules can be slid in, adding power capacity or providing internal redundancy (N+1).

With a 97.6 percent UPS module efficiency, 97.4 percent system efficiency in double conversion mode and 99 percent efficiency in ECO mode, the MF Series family are sure to cut your energy bill. The Xtra VFI double conversion mode improves efficiency under low-load conditions, making further savings.

Simply and safe installation is guaranteed as the UPS is provided with pre-engineered power frames that accommodate the modules and busbars that eliminate wiring entirely. Slide-in power modules with safe, plug-in connections remove any electrical hazard. To make external cabling easier, top or bottom cable entry can be chosen.

Maintenance and monitoring is easy too: Module replacement takes just a few minutes and maintenance can be performed in the comfort and safety of a separate room. Modules can be safely re-inserted without powering down. Real-time monitoring is provided by the local system display or a display on each module. The system can also be monitored remotely via the web application.

A variety of options for energy backup delivers the flexibility that users seek: The MF Series UPS can be installed with module-specific backup energy media for highest availability or a common battery for the whole UPS rack to optimize cost. The MF Series is also compatible with multiple lithium-ion batteries – a good option for those who look for further space savings without compromise in backup time. In addition, the system is ready for new energy storage technologies available in the market.

PowerExchanger is a function available on the MF Series enabling the UPS to interact with the grid and supply (upon external request) ancillary grid services. Through this frequency regulation function (FRF) the UPS can reduce/increase the input power flowing from the grid to the UPS or even reverse the flow and inject power back into the grid (back-feed), while maintaining constant output power.

Mechanical Characteristics MF Series with Distributed Bypass

Rehiko MF1500 DPA – 500 kVA Frame

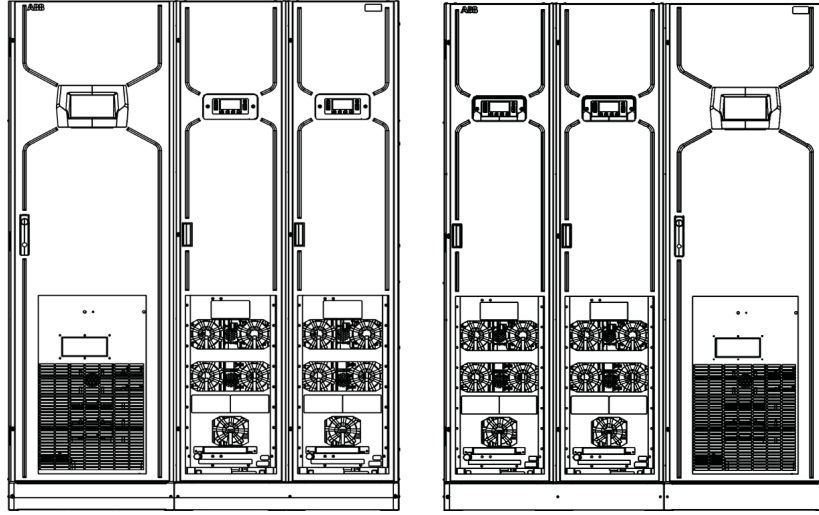

500kVA / 500kW Frame	1 Module	2 Module
System power rating (per cabinet) (kVA/kW)	250	500
Maximum cabinet rating	500 kVA / 500 kW (up to 3 power modules)	
UPS Frame Dimensions (W x D x H) mm	1422 x 1000 x 2000	
Weight (without power modules) kg	385	
Weight (with power modules) kg	1094	

Rehiko MF1500 DPA – 750 kVA Frame

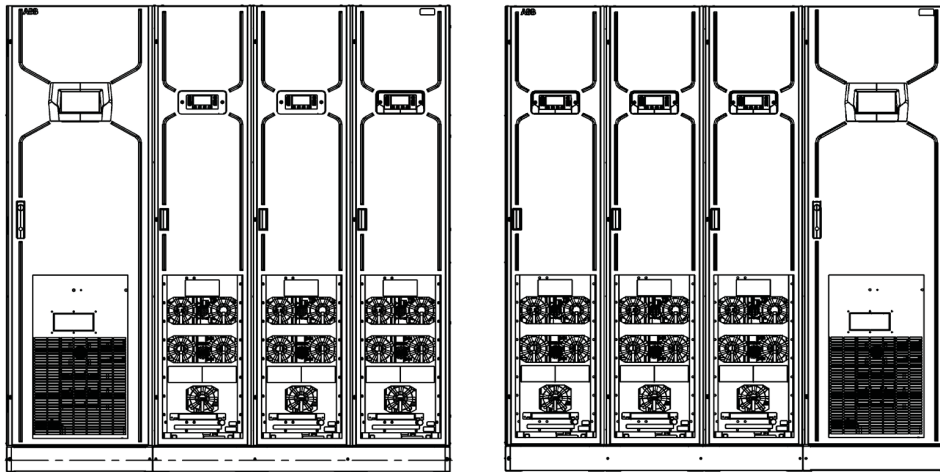

750kVA / 750kW Frame	1 Module	2 Module	3 Module
System power rating (per cabinet) (kVA/kW)	250	500	750
Maximum cabinet rating	750 kVA / 750 kW (up to 3 power modules)		
UPS Frame Dimensions (W x D x H) mm	1829 x 1000 x 2000		
Weight (without power modules) kg	466		
Weight (with power modules) kg	1530		

Rehko MF1500 DPA – 1000 kVA Frame

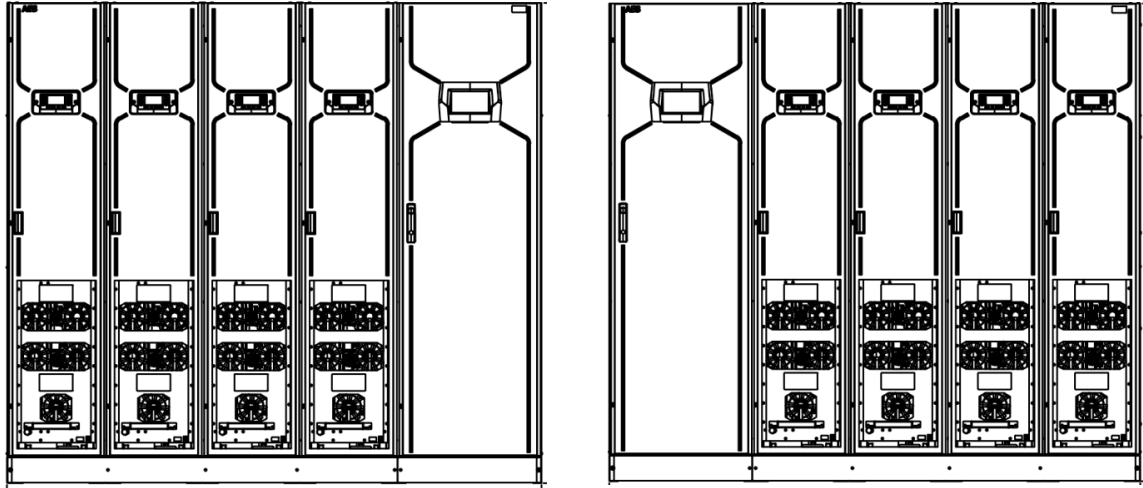

1000kVA / 1000kW Frame	1 Module	2 Module	3 Module	4 Module
System power rating (per cabinet) (kVA/kW)	250	500	750	1000
Maximum cabinet rating	1000 kVA / 1000 kW (up to 4 power modules)			
UPS Frame Dimensions (W x D x H) mm	2236 x 1000 x 2000			
Weight (without power modules) kg	547			
Weight (with power modules) kg	1965			

Rehko MF1500 DPA – 1250 kVA Frame

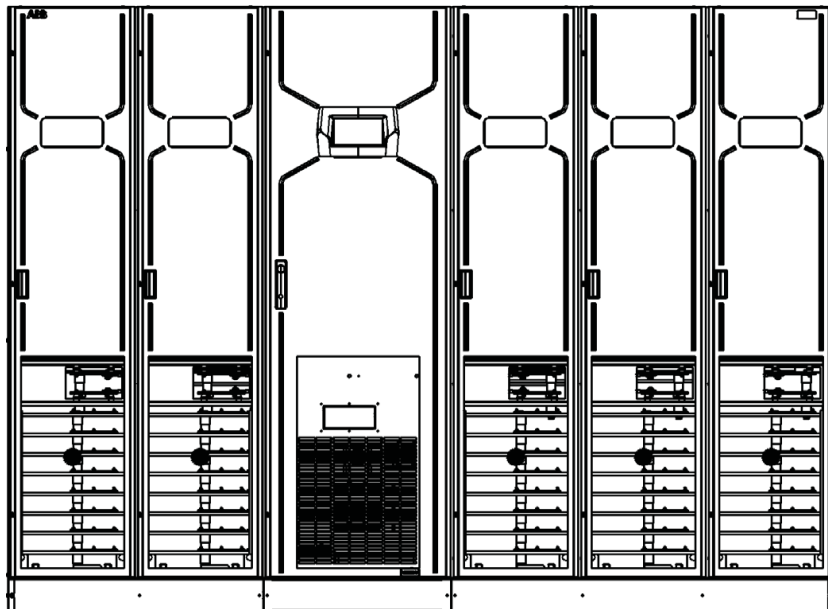

1250 kVA / 1250 kW Frame	1 Module	2 Module	3 Module	4 Module	5 Module
System power rating (per cabinet) (VA/kW)	250	500	750	1000	1250
Maximum cabinet rating	1250 kVA / 1250 kW (up to 6 power modules)				
UPS Frame Dimensions (W x D x H) mm	2643 x 1000 x 2000				
Weight (without power modules) kg	760				
Weight (with power modules) kg	2533				

Rehko MF1500 DPA – 1500 kVA Frame

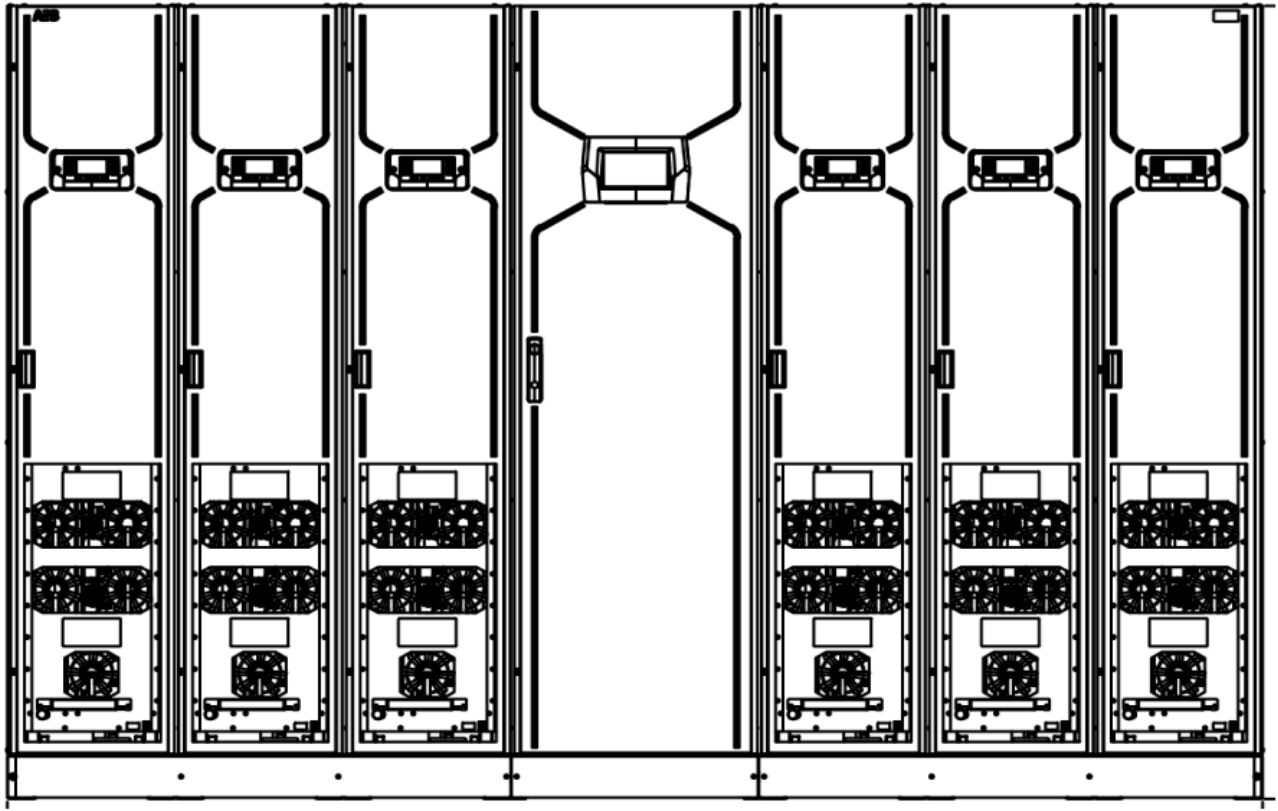

1500 kVA / 1500 kW Frame	1 Module	2 Module	3 Module	4 Module	5 Module	6 Module
System power rating (per cabinet) (kVA/kW)	250	500	750	1000	1250	1500
Maximum cabinet rating	1500 kVA / 1500 kW (up to 6 power modules)					
UPS Frame Dimensions (W x D x H) mm	3050 x 1000 x 2000					
Weight (without power modules) kg	895					
Weight (with power modules) kg	3022					

Rehiko MF1500 DPA – 250 kVA Power Module



250 KVA / 250 kW Power Module	1 Module
System power rating (per cabinet) (kVA/kW)	250
Module Input Fuse (Type gRL/gS)	500A
Module type	On-Line, transformerless, Modular, DPA
Dimensions (W x D x H) mm	356 x 1000 x 1825
Weight kg	354

GENERAL SPECIFICATIONS

General UPS Cabinet Specifications	
UPS cabinet colour	Standard RAL 9005 (other colours, as option, on-demand)
Ingress protection	IP20
Cable Entry	Bottom, Top, or Mix Flange connections as option, on demand
Ventilation	Front to top airflow
Service access	Front and top

Electromagnetic Compatibility	
Emission	C3
Immunity	C3

Environment characteristics	
Environmental service conditions	Indoor unconditioned, free from any corrosive gases and/or conductive dust. (according to IEC 62040-4:2013)
Climatic class	3K2 (according to IEC 60721-3-3:2019)
Pollution degree	Level 2 (according to IEC 60664-1:2020/AMD1:2025)
UV resistance	N.A
Ambient operating temperature range	0-40oC without declared values derating
Relative humidity range	<95% (non-condensing)
Ambient storage temperature range (see note)	-25-70oC (with humidity ≤90%, non-condensing)
Altitude without derating	up to 1000m
Altitude with derating	up to 3000m Above 2000 m operation, conformal coated option must be included.
Vibration	according to EN60721-3-2
Audible noise emission	76 dBA @Temp. room of 25 °C (according to IEC 62040-3:2021) 78 dBA @Temp. room of 40 °C (according to IEC 62040-3:2021)
Seismic Certification	ASCE 7-16 and 2018 IBC Seismic and Special Seismic Certification Site Class D (ICC-ES AC156) (2) EN 60068-3-3; IEEE 693-2018

Note: Elevated storage temperatures may impact useful life, specifically for the UPS capacitors. Ideal storage temperature is between +5 and +35°C and at relative humidity of up to 75%. Long term storage in an environment with high humidity should be avoided. Likewise, one should avoid storage in environments that contain halogenated gases (and other hazardous gases), spray or oil as well as exposure to any radiation.

ELECTRICAL CHARACTERISTICS

Power Rating	500kW	750kW	1000kW	1250kW	1500kW
Power Module rating kW	250				
No. Power Modules per Frame	2	3	4	5	6
Parallel system capability (Frames full with 250kW modules)	Up to 7 UPS Frames	Up to 6 UPS Frames	Up to 6 UPS Frames	Up to 4 UPS Frames	Up to 4 UPS Frames
Topology	Online double conversion VFI-SS-111				
Back-feed protection	Built in as standard				
Redundant power supply for the IT load	Fully compatible with all redundancy architectures: N (Tier 1); N+1 (Tier 2); 2N or N+N (Tier 3 and Tier 4); 2(N+1); Catcher; 4N/3; 5N/4, distributed redundancy and other redundancy architecture configurations.				
<ol style="list-style-type: none"> Standards Safety EMC Performance Environmental Manufacturing Energy Efficient PEP Eco Passport 	<ol style="list-style-type: none"> IEC/EN 62040-1 IEC/EN 62040-2; Class C3 VFI SS 111 - IEC/EN 62040-3 IEC 62040-4 ISO 9001:2015, ISO 14001:2015, OHSAS18001 SEAI- Triple E Product Registered & ACA Approval PEP-PCR-ed3-EN-2015 04 02 Product Environmental Profile certification in compliance with ISO 14025:2010 «Environmental labels and declarations. Type III environmental declarations». According to with EU Directives 2006 95 2004 108 and through compliance with standards IEC/EN 62040-1: General rules for electric safety; IEC/EN 62040-2: Electromagnetic compatibility and immunity (EMC); IEC/EN 62040-3: Performances and testing rules. 				
<ol style="list-style-type: none"> CE Mark 					

INPUT CHARACTERISTICS

Input AC Power Distribution	
Input AC power distribution system compatibility (earthing system)	TN-S, TN-C, TN-C-S
Input AC power distribution system wiring	3 Phase + Neutral + PE Optional (3W connection kit): 3ph + PE
Overvoltage category (as per IEC 62040-1 - overvoltage category)	Category II (As standard) Category III with Optional SPD, to be mandatory included (or inside UPS by factory UPS frame installed Options or External to UPS, located on mains incoming protection panel)
Input rated conditional short circuit current (Icc)	120 kA
Additional information	Single UPS Mains input connection
Input Voltage & Frequency	
Input rated voltage	380, 400 or 415 VAC (Phase to Phase) 220, 230 or 240 VAC (Phase to Neutral)
Input voltage tolerance 40°C @ 400VAC	Load <100% (-10%, + 15%) Load <80% (-20%, + 15%) Load <60% (-30%, + 15%)
Input rated frequency	50Hz or 60Hz
Input frequency tolerance	40Hz or 70Hz (nominal Frequency +_10Hz)
Slew rate	1 Hz/s

Input Current and Overload Characteristics	
Maximum input rated current - 400V (batteries 100% charged) *	378A Per 250 kVA module
Maximum input rated current - 400V (batteries charging) *	420A Per 250 kVA module
Total harmonic distortion (THDi), 100 % load - normal mode - linear load (at 400V input voltage; input THDU < 2%; tolerance of $\pm 0.3\%$ may apply)	<3%
Total harmonic distortion (THDi), 100 % load - normal mode - non-linear load (at 400V input voltage; input THDU < 2%; tolerance of $\pm 0.3\%$ may apply)	<3%
Rectifier input in-rush (% of rated current against time)	<100%
Rectifier input power factor (rated linear load; rated non-linear load)	100% load

*Maximum input rated current – 380V and 415V please contact Rehiko

EFFICIENCY CHARACTERISTICS

Efficiency	
Double conversion efficiency - 100% rated load	96.5%
Double conversion efficiency - 75% rated load	97.0%
Double conversion efficiency - 50% rated load	97.4%
Double conversion efficiency - 25% rated load	97.2%
Eco Mode VFD efficiency – 100% load	99.0%

According to IEC 62040-3 (UPS performance standard): Efficiency tolerance +/-0.2 %

All AC/AC efficiency VFI declared at system level, data refers without battery charging current, @nominal input conditions with nominal frequency and with resistive load. At 25°C Ambient temperature.

The 97.4% @400V efficiency point is declared at 25°C Ambient temperature with nominal frequency and with resistive load

OUTPUT CHARACTERISTICS

Output AC Power Distribution	
Output AC power distribution system compatibility (earthing system)	TN-S, TN-C, TN-C-S, TT
Output AC power distribution system wiring	3 Phase + Neutral + PE Optional (3W connection kit): 3ph + PE
Output Voltage	
Output rated voltage	380, 400 or 415 VAC (Phase to Phase) 220, 230 or 240 VAC (Phase to Neutral)
Output voltage variation - normal mode	+/- 1%
Output voltage variation - battery mode	+/- 1%
Total harmonic distortion (THDU), 100 % load - normal mode - linear load	<2%
Total harmonic distortion (THDU), 100 % load - normal mode - non-linear load	<4%
Total harmonic distortion (THDU), 100 % load - battery mode - linear load	<2%
Total harmonic distortion (THDU), 100 % load - battery mode - non-linear load	<4%
Voltage transient and recovery time - 100 % step load - linear	<4%, (<200ms)
Voltage transient and recovery time - 100 % step load - non- linear	<4%, (<200ms)
Voltage transient and recovery time – stored energy mode -100 % step load - linear	<4%, (<200ms)
Voltage transient and recovery time – stored energy mode -100 % step load – non-linear	<4%, (<200ms)
Output Frequency	
Output rated frequency	50Hz or 60Hz
Output frequency variation - normal mode	+/- 2% or 4% selectable (Synchronised with mains, allowing for transfer to static bypass)
Output frequency variation - battery mode	+/- 0.1%
Output frequency variation - free-running	+/- 0.1%
Synchronization (max ± % range of rated frequency)	+/- 2% or 4% selectable
Max synch. phase error (referred to a 360° cycle)	2°
Output Current	
Output rated current - 400V*	362A Per 250 kVA module
Inverter overload capability	110% load: Continuous ** 125% load: 10 minutes 150% load: 1 minute
Output overload – Battery Mode Worst scenario with battery close to end of discharge (Measured at 400Vdc)	105% load: 10 minutes 110% load: 5 minutes 120% load :1 minute
Output current limitation, "short circuit current" (% or rated current / time duration, Ph – N 230V) Short circuit tolerance: +/- 0.15 x In	2.8 x In, 40 ms (default) 2.5 x In, 100 ms 2.3 x In, 150 ms 2.2 x In, 200 ms 2.1 x In, 250 ms 2.1 x In, 300 ms
Output current limitation, "short circuit current" (% or rated current / time duration, Ph – Ph 400V) Short circuit tolerance: +/- 0.15 x In	2.4 x In, 40 ms (default) 2.2 x In, 100 ms 2.1 x In, 150 ms 2.0 x In, 200 ms 1.9 x In, 250 ms 1.9 x In, 300 ms
Fault clearing capability (normal mode / stored energy mode, 400V rated voltage)	2274A 500 kW System 3411A 750kW System 4060A 1000kW System 5074A 1250kW System 6087A 1500kW System

Output Power Factor	
Load power factor - rated	1.0
Load power factor - displacement (permissible lead-lag range)	0.6 lag to 0.8 lead

*Maximum output rated current – 380V and 415V please contact Rehlko

**110% Continuous inverter overload at rated input voltage window: 380/400/415 V, (50/60Hz); <35°C room ambient temperature

Note that operating above 100% of Inverter nominal capacity would raise an Overload Alarm

STATIC BYPASS CHARACTERISTICS

Static Bypass Switch	
Rated Current - 400V*	362A Per 250 kVA module
Bypass Overload (% of rated current / time duration)	110% load: continuous 140% load: 10 minutes 190% load: 2 minutes
Dynamic behaviour - manual transfer time bypass-to-inverter (and inverter-to-bypass)	Instantaneously
Conditional short circuit current Icc	120kA
Bypass voltage tolerance (% of rated voltage @ 400V)	-20% + 15%
Bypass fault clearing capability (% of rated current/ time duration)	15 In / 20ms

*Maximum Input Rated Current – 380V and 415V please contact Rehlko

BATTERY AND ENERGY STORAGE CHARACTERISTICS

Battery charger	
Max. Charge current	187.5A (d.c) per module
Max. Charge power	75 kW (d.c) per module
Max. Fault current rating	100kA (d.c)
Battery ripple current max.	400mA RMS
Nominal voltage (total)	480 VDC - 600 VDC
Stored energy time (back-up time at 100 % rated load)	Extended autonomy times without derating. Refer to battery autonomy calculators for correct sizing
Ambient reference temperature (To secure maximal service life)	Battery type dependent: Lithium ion: 25°C, VRLA: 20°C, NiCd: Refer to manufacturer provided information

Additional Battery Information	
End of discharge voltage (EOD)	3.20 V/Cell Samsung 2.80V/cell Vision 1.65 V/Cell VLRA 1.05 V/Cell Ni-Cd
Cable voltage drop recommendation	1%
Battery temperature compensation	Supported by standard UPS. Temperature sensor available as option
Battery test	Automatic battery test performed by UPS. Could run by Power Module (250kW) or at frame UPS full capacity power level

VRLA	
Design life	Ref to battery manufacturer provided information
Quantity of cells per string	VRLA 12 V: 40-50 blocks/ 240-300 cells
Nominal voltage (total)	480 VDC - 600 VDC
Max. discharge current @EOD 240cells	649.5A per 250kW module
Stored energy time (back-up time at 100 % rated load)	Extended autonomy times without derating. Refer to battery autonomy calculators for correct sizing
Restored energy time (re-charge time to 90 % capacity)	10 hours (varies on amount and size of used batteries)
Ambient reference temperature (To secure maximal service life)	20°C
Charge voltage (float)	2.23 V/Cell
End of discharge voltage	1.65 V/Cell
Battery temperature compensation	Supported by standard UPS. Temperature sensor available as option

Nickel Zinc - ZincFive	
Battery Cab	BC2
Number of Cabinets	1
Design Life	15
Quantity of cells per string	8 cells; 38 modules
Nominal range	383 VDC - 585 VDC
Nominal Capacity	80
Stored Energy time	Suitable for short autonomies
Ambient reference temperature (To secure maximum service life)	20-35°C
Restored energy time (re-charge time to 90 % capacity)	4hrs @22A charge current
Max. discharge current @EOD	687A per 250kW module

Lithium-Ion Samsung and Vision							
Battery Configuration	Samsung	Vision					
	136S	TP100	TP110	TP120	TP200	TP220	TP240
Minimum No. Of Cabinets	1	2			1		
Energy storage type	No integrated batteries, external energy needed						
Design life	15 years						
Quantity of cells per string	136 Cells 17 mods	160S1P cells 10 mods	176S1P cells 11 mods	192S1P cells 12 mods	160S2P cells 10 mods	176S1P cells 11 mods	192S1P cells 12 mods
Nominal voltage (total) Vdc	516.8	512	563.2	614.4	512	563.2	614.4
Nominal Capacity Ah	67	50	50	50	100	100	100
Stored energy time (back-up time at 100 % rated load)	Extended autonomy times without derating. Refer to battery autonomy calculators for correct sizing						
Max. discharge current @EOD 240cells	649.5A per 250kW module						
Restored energy time (re-charge time to 90 % capacity) Hrs	3 @22A charge	2.7 @25A Charge			2.7 @50A Charge		
Ambient reference temperature (To secure maximal service life)	18-28°C	20-25°C					
Maximum discharge current @EOD	1000kW 2406A 1250kW 3008A 1500kW 3609A 1750kW 4211A 2000kW 4812A	1000kW 2337A 1250kW 2922A 1500kW 3506A 1750kW 4091A 2000kW 4676	1000kW 2125A 1250kW 2656A 1500kW 3187A 1750kW 3718A 2000kW 4250	1000kW 1948A 1250kW 2435A 1500kW 2922A 1750kW 3409A 2000kW 3896	1000kW 2337A 1250kW 2922A 1500kW 3506A 1750kW 4091A 2000kW 4674	1000kW 2125A 1250kW 2656A 1500kW 3187A 1750kW 3718A 2000A 4250	1000kW 1948A 1250kW 2435A 1500kW 2922A 1750kW 3409A 2000kW 3896A

Lithium-Ion Ampace P100					
Battery Configuration	Ampace P100				
	6C 12 Modules	6C 11 Modules	6C 10 Modules	6C 9 Modules	
Minimum No. Of Cabinets	1	1	1	1	
Design life	15 years				
Quantity of cells per string	192S2P	176S2P	160S2P	144S2P	
Nominal voltage (total) Vdc	614.4	563.2	512	460.8	
Minimum voltage Vdc	537.6	492.8	448	403.2	
Nominal Capacity Ah	104	104	104	104	
Restored time to 90% SOC	1H@104A				
Ambient reference temperature (To secure maximal service life)	20-30°C				
Maximum discharge current @EOD	1000kW 1250kW 1500kW 1750kW 2000kW	1948A 2448A 2937A 3427A 3916A	2136A 2670A 3204A 3738A 4272A	2350A 2937A 3524A 4111A 4700A	2611A 3263A 3916A 4568A 5222A

Ampace PU-100 Sizing basic guide

Common battery configuration (Optional «Common Battery connection kit» installed at UPS Frame)



Note: Dedicated per-frame-size Optional - Common Battery connection kit should be added on the MF Series UPS cabinet.

Battery cabinets are connected in common configuration to the frame.

MF Series Family - Common battery config. - Ampace Sizing for 5 min EOL							
Power Rating		500	750	1000	1250	1500	2000
PU-100 cabinet		2	3	4	4	5	7
N° Battery Modules per cabinet		10	10	10	12	12	12
Master Kit required		1	1	1	1	1	1
EOL 10 years	[min]	8.7	8.7	9.68	9.29	9.68	9.32
Voltage range	[Vdc]	400 - 576	400 - 576	400 - 576	480 - 691	480 - 691	440 - 634
Max current	[kAdc]	1.3	2.0	2.6	3.0	3.3	4.7

MF Series Family - Common battery config. - Ampace Sizing for 10 min EOL							
Power Rating		500	750	1000	1250	1500	2000
PU-100 cabinet		2	3	4	5	6	7
N° Battery Modules per cabinet		12	12	11	11	11	12
Master Kit required		1	1	1	1	1	1
EOL 10 years	[min]	10.4	10.4	10.65	10.65	10.65	10.17
Voltage range	[Vdc]	480 - 691	480 - 691	440 - 634	440 - 634	440 - 634	480 - 691
Max current	[kAdc]	1.1	1.6	2.2	2.7	3.2	4.4

Separate battery configuration (Standard from factory - Separate battery per each UPS Module)



Ampace Sizing for 5 min EOL		
Power Rating		250kW
PU-100 cabinet		1
N° Battery Modules per cabinet		10
Master Kit required		1
EOL 10 years	[min]	8.7
Voltage range	[Vdc]	400-576
Max current	[kAdc]	0.7

Ampace Sizing for 10 min EOL		
Power Rating		250kW
PU-100 cabinet		1
N° Battery Modules per cabinet		12
Master Kit required		1
EOL 10 years	[min]	8.4
Voltage range	[Vdc]	480-691
Max current	[kAdc]	0.6

POWER EXCHANGER

PowerExchanger is a function enabling the UPS to interact with the grid and supply (upon external request) ancillary grid services. Through this function the UPS is able to reduce/increase the input power absorbed from the grid or even to inject power into the grid (backfeed), while maintaining constant the output power.

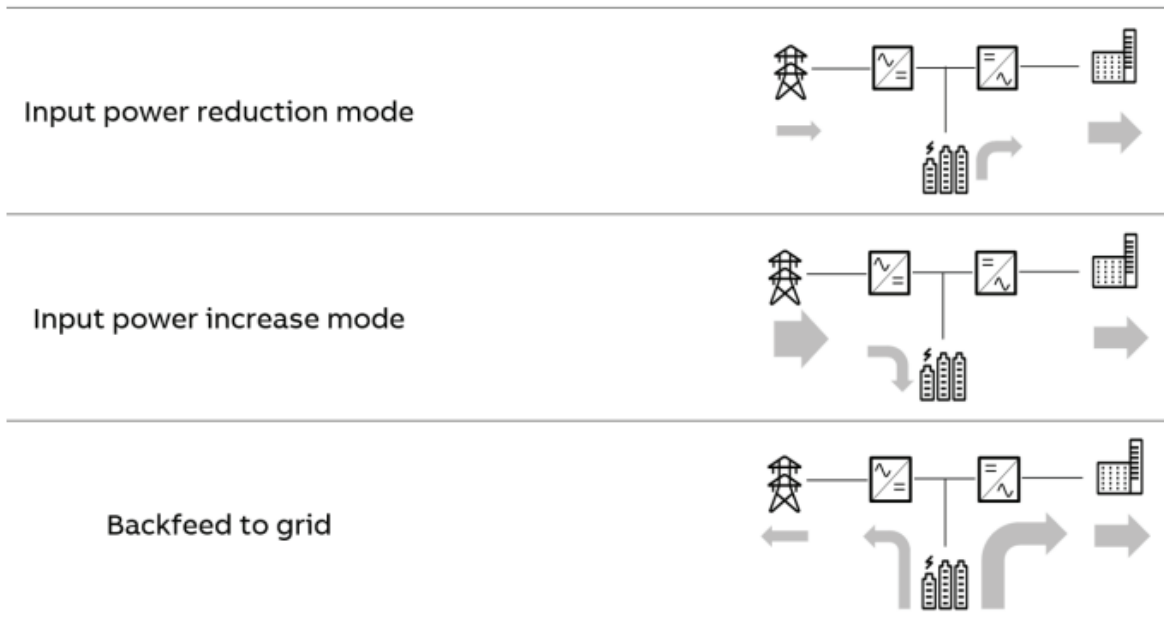

Input power reduction mode

Activation power (input reduction)	From actual load down to 0%
Response time from activation request	< 1 Second
Input power reduction duration	Modbus RTU: until minimum state of charge is reached dry contact: 0-200, selectable
Deactivation ramp	Modbus RTU: instantaneous control, dynamic setpoint dry contact: 0-100%, selectable
Battery minimum state of charge*	0-100%, selectable
Battery type compatibility	VRLA, Li-Ion**, NiCd
Communication with external gateways	Modbus RTU or dry contact***
Activation	Dedicated Module 1 license

*defines the minimum level beyond which the input power reduction mode is inhibited

**valid for Li-Ion batteries officially compatible with this UPS, lithium iron phosphate battery is recommended.

***if dry contact communication is selected, the activation power is a predefined setpoint (programmable)

Input power increase mode

Input power increase	Max 75Kw/UPS module, on top of actual load. (limitations may apply depending on initial battery state of charge)
Response time from activation request	< 1 Second
Input power increase duration	Modbus RTU: until minimum state of charge is reached dry contact: 0-200, selectable
Deactivation ramp	Modbus RTU: instantaneous control, dynamic setpoint dry contact: 0-100%, selectable
Battery maximum charge status*	0-100%, selectable
Battery type compatibility	Li-Ion**
Communication with external gateways	Modbus RTU or dry contact***
Activation	Dedicated Module 1 license

* during input power increase mode the battery is charged, therefore, to enable this mode the battery should be normally kept in a partial state of charge; this parameter specifies the maximum charge allowed (100% equals then to disabling the function). The initial state of charge and the amount of battery capacity installed influences the amount of power increase.

** valid for Li-Ion batteries officially compatible with this UPS, lithium iron phosphate battery is recommended.

*** if dry contact communication is selected, the activation power is a predefined setpoint (programmable).

Backfeed to Grid

Activation power (backfeed to grid)	Up to 175kW/UPS module exported towards the grid
Response time from activation request	< 1 Second
Backfeed to grid duration	Modbus RTU: until minimum state of charge is reached dry contact: 0-200, selectable
Deactivation ramp	Modbus RTU: instantaneous control, dynamic setpoint dry contact: 0-100%, selectable
Battery maximum charge status*	0-100%, selectable
Battery type compatibility	VRLA, Li-Ion**, NiCd
Communication with external gateways	Modbus RTU or dry contact***
Activation	Dedicated Module 1 license

* defines the minimum level beyond which the back feed reduction mode is inhibited

** valid for Li-Ion batteries officially compatible with this UPS, lithium iron phosphate battery is recommended.

*** if dry contact communication is selected, the activation power is a predefined setpoint (programmable)

REMOTE CONTROL AND MONITORING

Communications - Hard Wired (fitted as standard)	
Inputs dry ports X1, X7, X8	X1 / X7 / X8 can hold Cable from 0.2mm ² – 1.5mm ² All X1 / X7 / X8 are inputs, cable max. R 50Ω at 10mA X1 (4 inputs): Generator operation ON, External output breaker, external manual bypass, remote shut down X7-X8 (8 inputs) are programmable inputs
High voltage input port X12	X12 terminals can hold Cable from 0.2mm ² – 1.5mm ² X12 are inputs rated: Min. 87 Vac – Max. 277 Vac 50Hz/60Hz X12 are programmable inputs
Input analog port X6	X6 can hold Cable from 0.2mm ² – 1.5mm ² All X6 are analogue inputs, designed for sensors with standard industry output 1-24Vdc or 4-20mA
Input battery temperature sensor X3	X3 can hold Cable from 0.2mm ² – 1.5mm ²
Modbus communication power X4	X4 terminals can hold Cable from 0.2mm ² – 1.5mm ² X4 are differential 5V RS485 signals
CAN bus communication port X5	X5 terminals can hold Cable from 0.2mm ² – 1.5mm ² X5 are differential 5V RS485 signals
Output dry port X2,X10, X11	X2, X10 and X11 terminals can hold Cable from 0.2mm ² – 1.5mm ² X2, X10 and X11 are potential free contacts and are rated: Max 30Vac/1A; 60Vdc/0.5A. X2 (4 outputs) : common alarm, battery low, load on inverter, main failure X10,X11 (8 outputs) are programmable outputs
High voltage output power X13	X13 terminals can hold Cable from 0.2mm ² – 1.5mm ² X13 are output rated: Max. 5A @ 277 Vac or 5A @ 30VDC X13 are programmable outputs
Output + 24dc X9	X9 can hold Cable from 0.2mm ² – 1.5mm ² X9 is an output port rated: 24Vdc @ 100mA Max
Synchronization input port X14	X14 terminals can hold Cable from 0.2mm ² – 1.5mm ² X14 are inputs and are rated: Max. 415 Vac
Communications - Network Card Options	
Slot 1	SNMP Card or Modbus TCP/IP or Modbus RS-485
Slot 2	SNMP Card or Modbus TCP/IP or Modbus RS-485

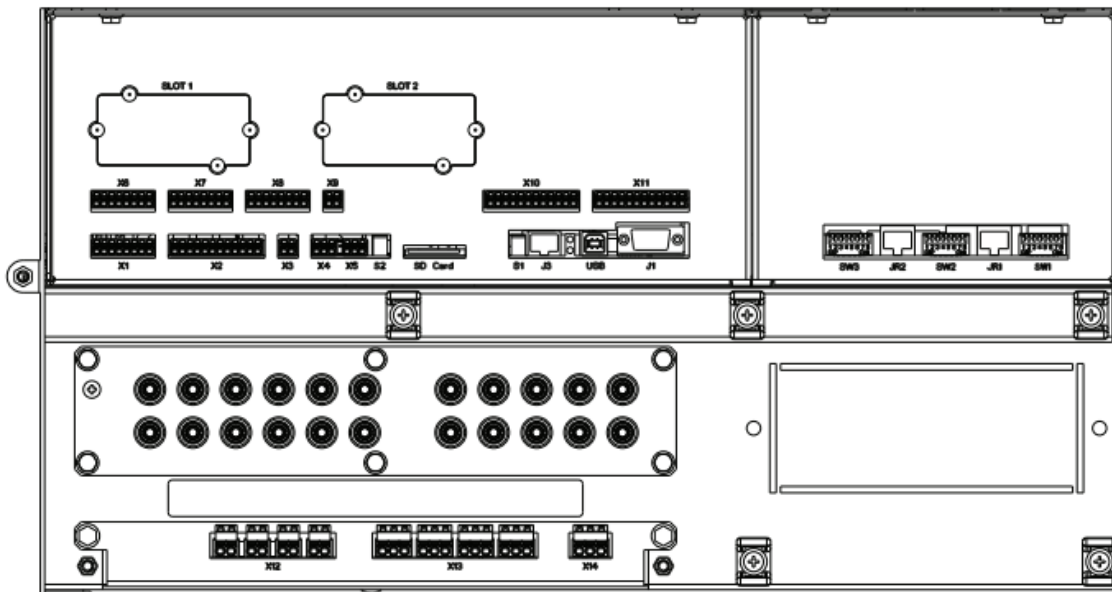

UPS CONTROL AND MONITORING

System Control Panel

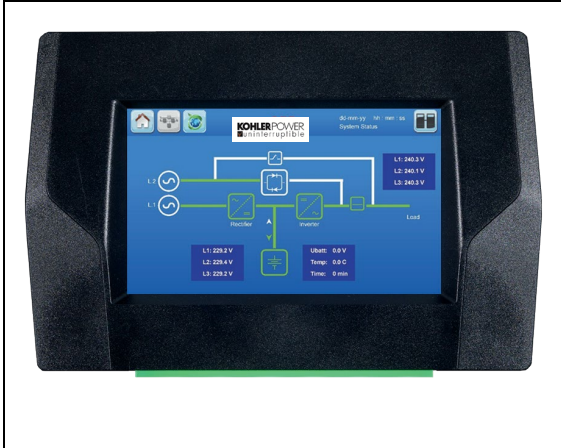

Each UPS system has a system graphical display. It is a 7" touchscreen display enabling the operator to perform:

- Monitoring and measuring of the power flow through the UPS system, individual power modules and batteries
- Monitoring of UPS operational status, events, and alarm history
- If the system control panel fails each module can still be operated using their own panel
- UPS setting configuration
- UPS Data

Module Control Panel

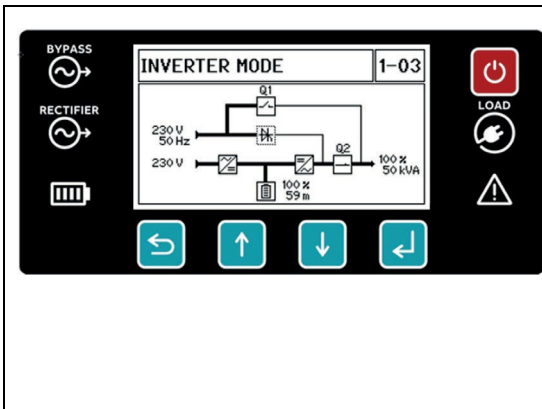

The power module has its own control panel consisting of an LCD display, control and navigation buttons and led status indicators. The LCD display shall display:

- Mimic diagram of the power module showing the rectifier, battery, static bypass, inverter status and the input, bypass, battery, and output measurements: voltage, frequency, power
- Power module status: off, disconnected, inverter mode, bypass mode, battery mode, stand-by mode
- Power module location: Power frame and power module number

The control and navigation buttons shall allow the user to perform settings and adjustments, monitor the voltages, currents, frequencies, power measurements and scroll the main and sub-menus in the UPS module.

The user shall be able to identify the status of the bypass, rectifier, battery and UPS output and the alarm by reading the LED indicators. The LEDs are always active even if the display is in screensaver mode. Please refer to the OPM for more information.

INSTALLATION AND PLANNING

INSTALLATION PLANNING

The following *guidelines* should be considered when planning a suitable UPS location and working environment.

Location considerations summary

- The UPS equipment must be installed and transported in an upright position.
- The floor at the installed location and en-route from the off-loading point must be able to safely take the weight of the UPS and battery equipment.
- The floor material where the UPS is to be located should be non-flammable.
- Local fire protection standards must be respected.
- The appropriate power supplies must be accessible so that the UPS cabling can be performed easily.

Environmental considerations summary

- Avoid high ambient temperature, moisture, and humidity. The prescribed limits are humidity (<90% non-condensing) and temperature (0°C to +40°C and ideally 18°C to 25°C).
- A battery temperature of 20°C is recommended for VRLA to achieve a long battery life.
- Any prescribed air-cooling flow must be available. Ensure the air conditioning system can provide enough air cooling to keep the room at, or below, the maximum desired temperature.
- No dust or corrosive/explosive gases should be present.
- The location must be vibration-free.

UPS Cabinet Installation

Before moving the UPS to its final position, carry out any necessary pre-installation cabling (power and control cables) to ensure that full cable access is available once the UPS is placed in-situ. Top or bottom cable access is possible, or a combination of the two.

Battery Installation

The battery system should be contained in a purpose-designed cabinet or mounted on a suitable open or closed battery rack. The battery cabinet can be positioned on either side of the UPS cabinet and they can also be in a separate room or location. If the batteries are to be mounted on external battery racks, rather than cabinet mounted, the battery must be sized to consider the voltage drop between the battery installation and UPS. Contact Rehiko Ltd. For installation advice and support if necessary.

UPS FOOTPRINT AND CLEARANCES

The minimum needed clearances to allow sufficient airflow on the UPS system and to allow proper services and maintenance shall be respected as reported below

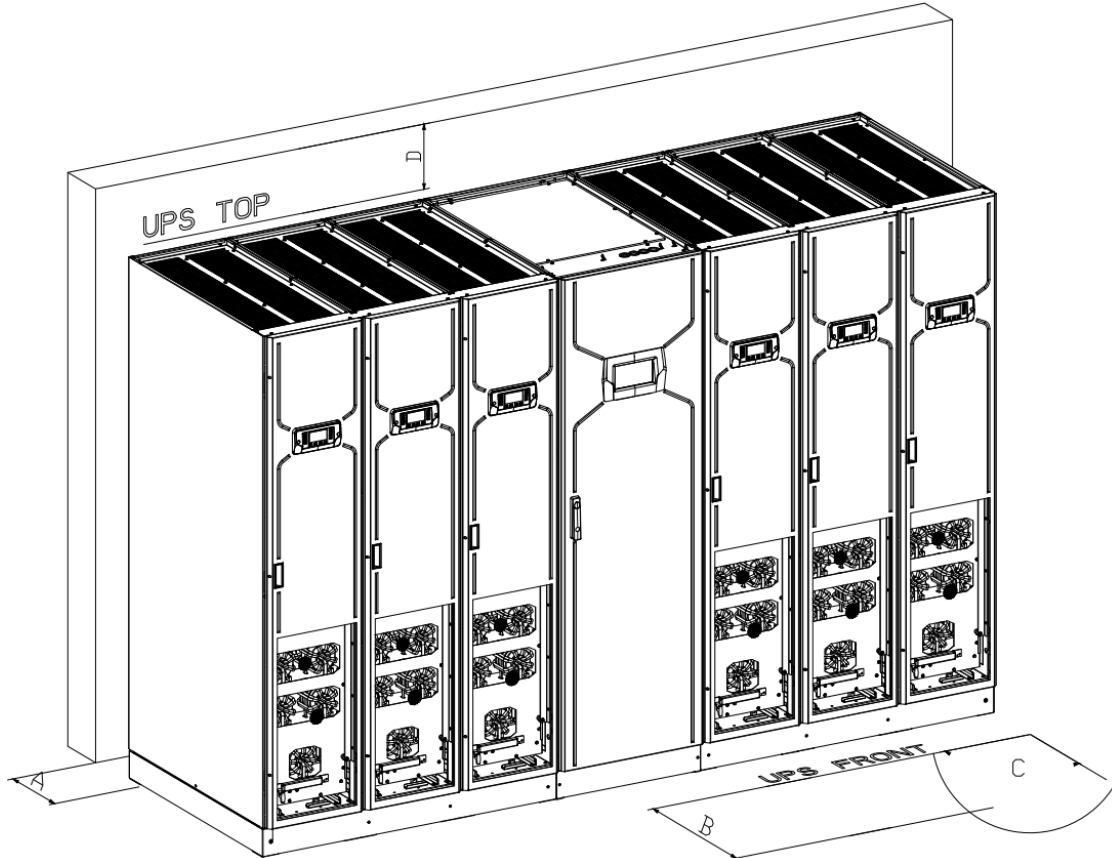

UPS Clearances	
A - Rear clearance for ventilation	0 mm (Can be positioned against a wall)
B - Front clearance to allow door to open	1500 mm *
C - Maximum door opening angle	95°
D - Top clearance	500 mm

*Front clearance of 1,200mm can be accepted if the power module is removed by 2 service engineers.

CABLE PLANNING

The UPS cabinets are designed for a single input feed, where the UPS input mains supply is connected internally to the UPS bypass terminal. The first diagram below, shows the batteries being connected ‘Separately’ to each Power Module and the second diagram below, shows the batteries being connected in a ‘Common’ arrangement to the UPS Frame.

It is the customer’s responsibility to design and install the UPS supply and distribution circuits and provide the external fuses, isolators and cables required to connect the UPS input and output power supplies.

The information provided in this section should assist in the planning and preparation of the UPS power cabling.

As shown below, the UPS input mains should be connected to the UPS system via a circuit breaker or fused device. The input device provides a means of isolating the UPS from the utility mains supply and must be suitably rated to provide overload protection for the UPS. Similarly, the UPS output should be connected to the load equipment via a suitably protected UPS system output panel.

The tables below shows the maximum UPS input and output current for each set of cables together with the cable termination details. This is provided to assist the customer in selecting appropriately rated power cables and external switchgear.

Cable Terminations

Terminals Description	Label	Cable Size	Torque (Nm)
Input Line L1	X3.1: L1	M12 Bolt Terminal	42
Input Line L2	X3.1: L2	M12 Bolt Terminal	42
Input Line L3	X3.1: L3	M12 Bolt Terminal	42
Neutral Bar (Common Neutral)	X6: N	M12 Bolt Terminal	42
Earth Bar (Common Earth)	X7 : PE	M12 Bolt Terminal	42
Output Line L1	X2.1: L1	M12 Bolt Terminal	42
Output Line L2	X2.1: L2	M12 Bolt Terminal	42
Output Line L3	X2.1: L3	M12 Bolt Terminal	42
Battery Terminal +	X501.1: +	M12 Bolt Terminal	42
Battery Terminal -	X502.2: -	M12 Bolt Terminal	42

Single Input Feed with Separate Battery Connection

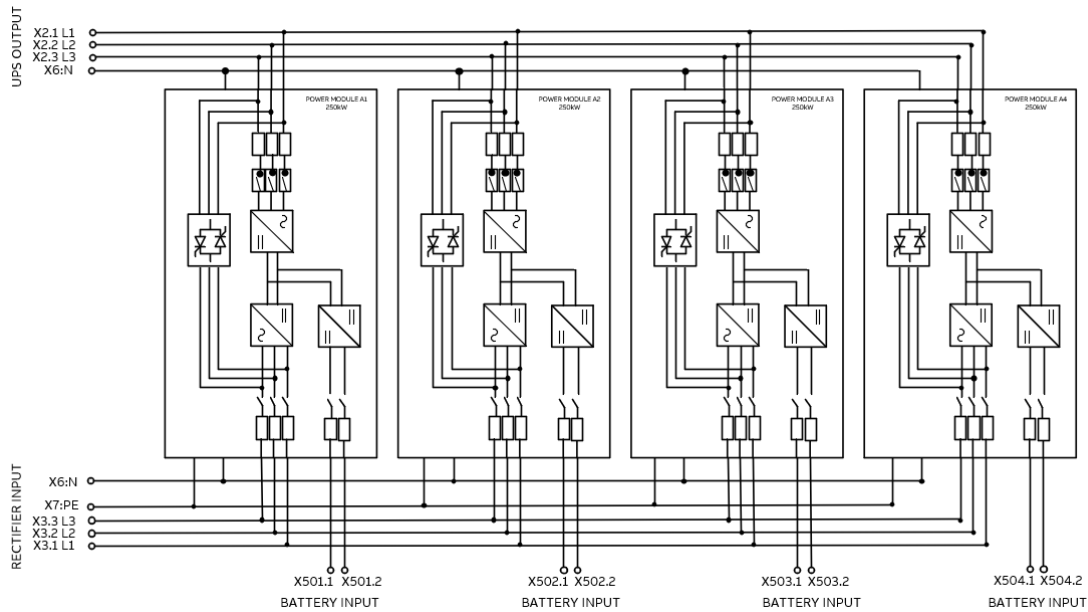

Note: The above Schematic shows are 1000kW Frame. If a 1500kW Frame is selected, the schematic would have an additional 2 power modules.

In a 'Separate battery' installation the UPS battery busbars are removed, and the individual battery positive and negative cables are connected directly to the modules' battery circuit breaker (F3)

Input /output protection values calculated at 380V

Recommended external protection & Cables	500kVA	700kVA	1000 kVA	1250 kVA	1500 kVA
Rectifier input fuse gL or MCCB	800A	1250A	1600A	2000A	2500A
Rectifier input cable section (L1,L2,L3,N)	4 x (2 x 300mm ²)	4 x (3 x 300mm ²)	4 x (4 x 300mm ²)	4 x (5 x 300mm ²)	4 x (6 x 300mm ²)
UPS output fuse gL or MCCB, 3P or 4P	800A	1250A	1600A	2000A	2500A
Output cable section (L1,L2,L3,N)	4 x (2 x 300mm ²)	4 x (3 x 300mm ²)	4 x (4 x 300mm ²)	4 x (5 x 300mm ²)	4 x (6 x 300mm ²)
Separate Battery					
Battery input fuse gR or MCCB (Separate to each module)	2x630A per module				
Battery Cable section (+,-) (Separate to each module)	4x185mm ² per module				
Earth cable section (PE)	1 x 185mm ² Per module				

Single Input Feed Common Battery Connection

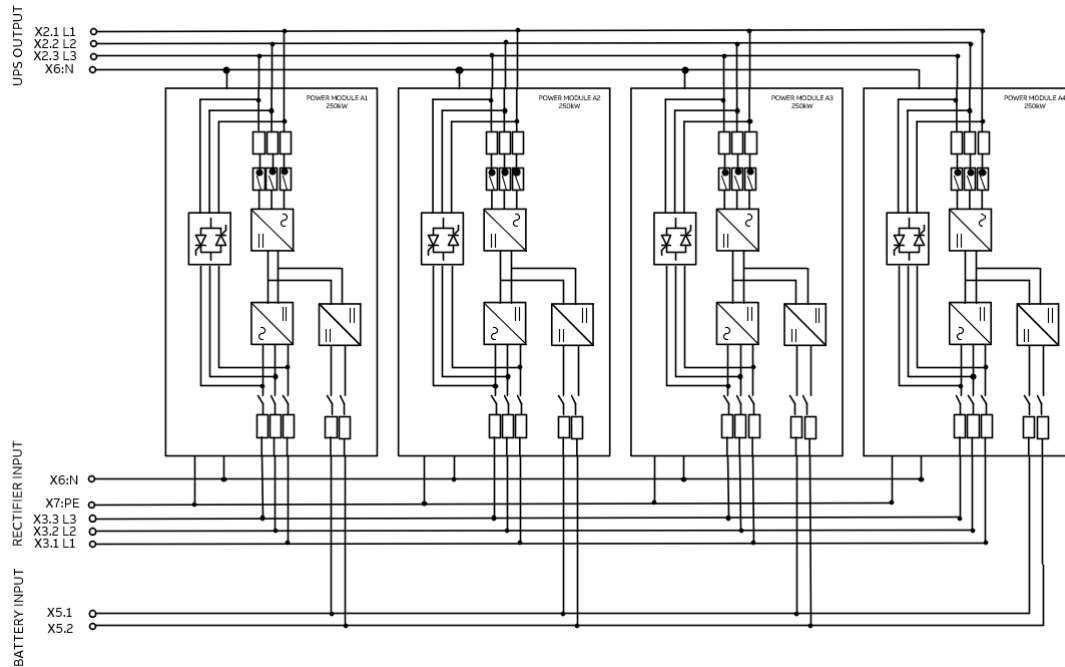

Note: The above Schematic shows a 1000 kW Frame. If a 1500 kW Frame is selected, the schematic would have an additional 2 modules

In a 'common battery' installation (as shown) the battery positive and negative cables are connected to the common battery busbars which are located adjacent to the UPS input/output mains busbars

Recommended external protection & Cables	500kVA	700kVA	1000 kVA	1250 kVA	1500 kVA
Rectifier input fuse gL or MCCB	800A	1250A	1600A	2000A	2500A
Rectifier input cable section (L1,L2,L3,N)	4 x (2 x 300mm ²)	4 x (3 x 300mm ²)	4 x (4 x 300mm ²)	4 x (5 x 300mm ²)	4 x (6 x 300mm ²)
UPS output fuse gL or MCCB, 3P or 4P	800A	1250A	1600A	2000A	2500A
Output cable section (L1,L2,L3,N)	4 x (2 x 300mm ²)	4 x (3 x 300mm ²)	4 x (4 x 300mm ²)	4 x (5 x 300mm ²)	4 x (6 x 300mm ²)
Common Battery					
Common connection Battery input fuse gR or MCCB. (1 input for full frame)	1250A	2000A	2500A	3200A	4000A
Battery cable section, 2 poles, cable section (+) & (-)	2x (2x 185 ² mm)	2x (3x 185 ² mm)	2x (4x 185 ² mm)	2x (5x 185 ² mm)	2x (6x 185 ² mm)
Earth cable section (PE)	2 x 185mm ²	3 x 185mm ²	4 x 185mm ²	5 x 185mm ²	6 x 185mm ²

Heat Dissipation

UPS Power Rating		500kW	750kW	1000 kW	1250 kW	1500 kW
Maximum Airflow EN62040-1	M3/h	3788	5682	7576	9470	11364
	CFM	2230	3344	4459	5574	6688
Heat Dissipation 25% Load	W	3588	5381	7175	8969	10763
	BTU/h	12243	18360	24482	30603	36725
Heat Dissipation 40% Load	W	5233	7850	10467	13084	15700
	BTU/h	17855	26785	35715	44644	53570
Heat Dissipation 50% Load	W	6674	10010	13347	16684	20021
	BTU/h	22772	34155	45541	56928	68314
Heat Dissipation 75% Load	W	11439	17158	22877	28596	34316
	BTU/h	39031	58545	78060	97573	117091
Heat Dissipation 100% Load	W	18350	27524	36699	45874	55049
	BTU/h	62613	93916	125222	156528	187835
Heat Dissipation No Load	W	2000	3000	4000	5000	6000
	BTU/h	6824	10236	13647	17059	20471

STANDARD FEATURES

Cold Start

The cold start function allows starting a UPS (or UPS module) without the input mains present during the status UPS total off. The start-up could then be performed directly sourcing from the battery to feed the inverter to supply the relevant load during a limited time (battery charge and load dependable).

UPS power walk-in when transferring back from batteries to utility

It's possible to set a ramp-up on modules (rectifier walk-in activation) and a delay on connecting each system module to facilitate returns after mains failure without impacting on full power demand-in.

When system detects input mains (utility) restored to nominal values, the first module ramp-up will start after a configurable delay. Rectifier automatically starts with the walk -in as soon as the input mains is within tolerance. Meanwhile load is supported from Battery-Inverter operation. Every additional module will start (also ramp-up) after previous module, with configurable delay.

UPS power walk-in	
First module ramp-up configurable delay	1-20 Seconds
After first module full loaded, every additional module step-activation	3 – 60 (set in 3 second steps)
Example MF Series 1000kVA frame 4x250kW modules	
“Fastest” configurable TOTAL walk-in for (4 x M250) example	First module starting after 1 sec.; Last one module starting after 10 sec. Total sequence: (1 + 3 + 3 + 3 = 10 sec)
“Slowest” configurable TOTAL walk-in for (4 x M250) example	First module starting after 20 sec.; Last one module starting after 200 sec. Total sequence: (20 + 60 + 60 + 60 = 200 sec)

Synchronization Feature

The MF Series Synchronization Feature enables to synchronize the output voltage of one or more UPS Slave-group/s (single UPS frame or a parallel system composed of multiple UPS frames) with any AC electrical line. For more information on the procedure and configuration, refer to the User/Installation product Manual.

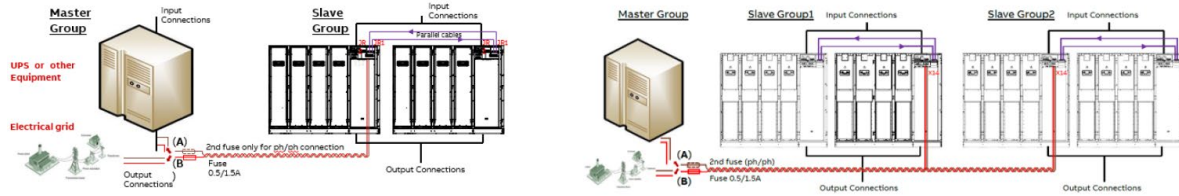

Castell Key Interlock

Castell key interlock functionality can be applied between UPS and the external manual bypass switch to avoid unnecessary switching between Modes of Operation producing an interruption of power supply for the critical load. The Castell key interlock is usually consisting of two locks (MBS & KSS Solenoid Switch) and one key.

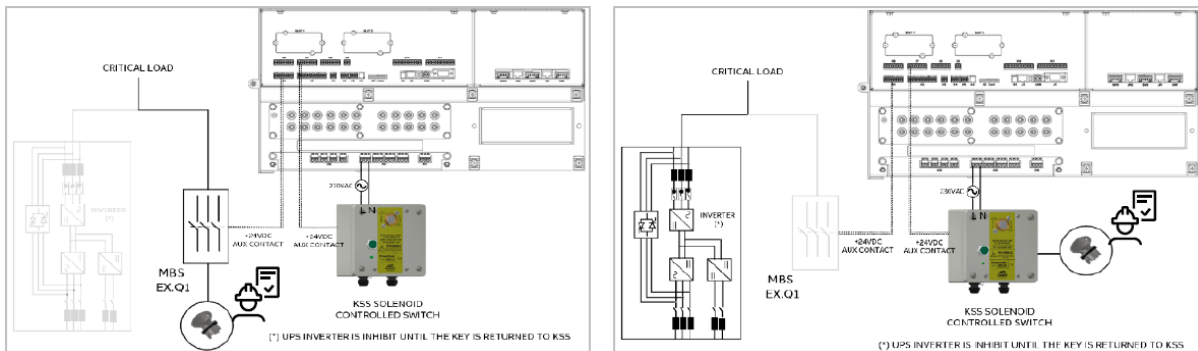

The KSS interlock device is an external piece of hardware, not provided by Rehiko. Additional external wiring connections to interface unit and UPS secured power supply are required for the KSS interlock device. **See User Manual to see connections and more information.**

External Maintenance Bypass Switch and Output Switch connections

The monitoring of the external maintenance bypass switch (EXT Q1) and the external output switch (EXT Q2) is mandatory for the UPS operation.

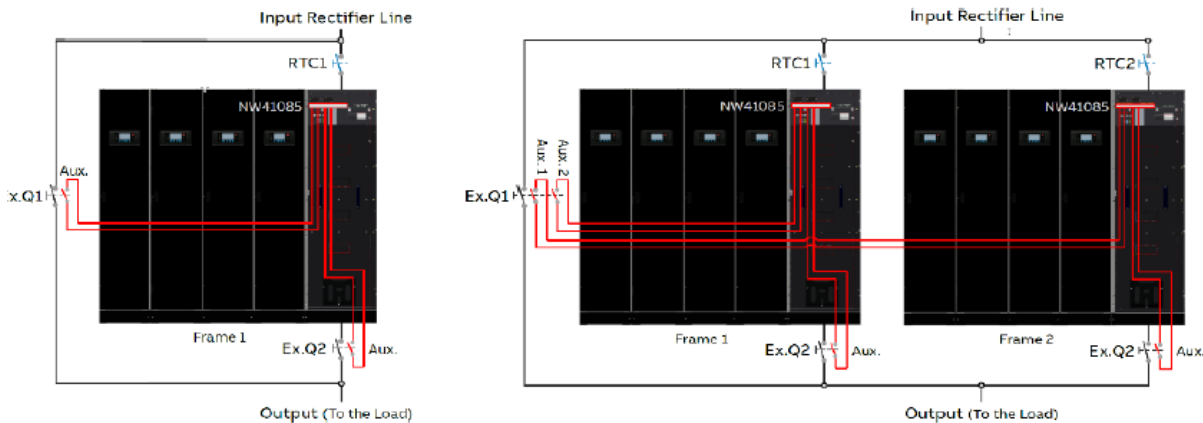

Therefore, the auxiliary contacts of EXTQ1 and EXT Q2 should be connected to the to the input dry port X1 in the communication interface.

For more information on the procedure and configuration, refer to the User Manual.