



REHLKO *EW* 6000-Li

Compact, fully integrated single or three phase UPS system with internal power distribution and lithium-ion battery modules

(6-10 kVA single phase, 10-40 kVA three phase)

User Manual

Document Control

ISSUE	DATE	REVISION SUMMARY
TS_825_01	18/05/2026	Rebranded to Rehlko

Useful Contacts

UK

www.ups.rehlko.co.uk

ukservice.ups@rehlko.com

uktechnicalsupport.ups@rehlko.com

uksales.ups@rehlko.com

ukservicesales.ups@rehlko.com

Rehlko web site

Service department – booking service, fault reporting etc.

Technical queries

Hardware sales

Extended warranty agreements etc

IRELAND

www.ups.rehlko.ie

ieinfo.ups@rehlko.com

Rehlko web site

Service department, technical queries, hardware sales and extended warranty agreements

SINGAPORE

www.ups.rehlko.sg

salesups.sg@rehlko.com

serviceups.sg@rehlko.com

Rehlko web site

Hardware sales

Contract customer support, maintenance contracts renewals

All product, product specifications and data are subject to change without notice to improve reliability, function, design or otherwise. Rehlko has taken every precaution to produce an accurate, complete and easy to understand specification document and will assume no responsibility nor liability for direct, indirect or accidental personal or material damage due to any misinterpretation of, or accidental errors, in this manual.

© 2026 Rehlko

This document may not be copied or reproduced without written permission of Rehlko.

Foreword

Summaries

Thank you for choosing the Rehiko EW 6000-Li system.

This document gives a description of the Rehiko EW 6000-Li system, including the features, performance, appearance, structure, working principles, installation, operation and maintenance, etc.

Please save the manual after reading, in order to consult in the future.

NOTE







The figures in this manual are just for illustration; details please take the actual product as standard.

Suitable Model

REHLKO EW 6000-Li

Symbol Conventions

The manual quotes the safety symbols, these symbols used to prompt users to comply with safety matters during installation, operation and maintenance. Safety symbol meaning as follows.

Symbol	Description
 DANGER	Alerts you to a high risk hazard that will, if not avoided, result in serious injury or death.
 WARNING	Alerts you to a medium low risk hazard that could, if not avoided, result in moderate or minor injury.
 CAUTION	Alerts you to a low risk hazard that could, if not avoided, result in minor injury.
	Anti-static prompting.
	Beware of electric shock hazard.
 TIP	Provides a tip that may help you solve a problem or save time.
 NOTE	Provides additional information to emphasize or supplement important points in the main text.

Product standard: Q/ZZKJ015

Contents

1 Safety Description	1
1.1 Safety Announcements	1
1.1.1 Statement	1
1.1.2 General Requirements	2
1.2 Electrical Safety	2
1.2.1 Input/Output	3
1.2.2 Grounding Requirements	4
1.2.3 Wiring Requirements	6
1.2.4 Anti-static Requirements	8
1.3 Operation & Maintenance Requirements	9
1.3.1 Lithium-ion Battery Module Requirements	9
2 Overview	25
2.1 Product Intro	10
2.1.1 Name Meaning	11
2.1.2 Feature	11
2.2 Work Principle	13
2.3 Appearance and Structure	14
2.3.1 Appearance	15
2.3.2 Structure Layout	18
2.3.3 Communication Method	18
2.3.4 Lithium-ion Battery Module	18
2.3.5 Heat Dissipation Description	19
3. Installation	25
3.1 Installation Process	25
3.2 Installation Preparation	29
3.2.1 Installation Tools	29
3.2.2 Installation Environment	29
3.2.3 Installation Space	30
3.3 Transport and Unpacking	31
3.3.1 Transporting	33
3.3.2 Unpacking	34
3.3.4 External maintenance bypass switch	29
3.4 System Installation	37
3.5 Lithium-ion Battery Module Installation	37
3.6 SNMP Card Installation (Optional)	37
4 Electrical Connection	37
4.1 Cable & Breaker Preparation	39
4.1.1 Switch Selection	40
4.1.2 Select Wire	41
4.2 System Wiring	45
4.2.1 Input & Output Wiring	48
4.3 Communication	50

4.4 Check the Installation	50
5 Touch Screen Operation	52
5.1 Menu Hierarchy	52
5.2 Main Page	52
5.2.1 Working Status	53
5.2.2 Icon Meaning	53
5.2.3 Bypass Information	53
5.2.4 Mains Information	54
5.2.5 Battery Information	56
5.2.6 Output Information	56
5.3 Login	57
5.4 Information Management	62
5.4.1 Run Information	63
5.4.2 History Record	64
5.4.3 User Log	70
5.4.4 Device Information	70
5.5 Device Management	70
5.5.1 Battery Manage	71
5.5.2 Battery Test	71
5.5.3 Communication Setting	71
5.5.4 HMI Setting	73
5.5.5 Password Setting	73
5.5.6 Record Manage	74
5.5.7 Upgrade	74
5.6 Current Fault	75
5.7 Buzzer Control	75
5.8 ON/OFF Operation	76
5.8.1 Power on Operation	76
5.8.2 Power off Operation	77
6 Daily Operation	73
6.1 Use Announcements	79
6.2 Startup Operation	
6.3 Shutdown Operation	
6.4 Lithium-ion Battery Module Cold Start	
6.5 Maintenance Bypass Operation	
6.5.1 Maintenance Bypass Power Mode	
6.5.2 Maintenance Bypass Power Restoration to Inverter Power	
7 Troubleshooting	73
7.1 Safety Precautions	79
7.2 Preventive Maintenance	
7.3 Maintenance of Battery Module	
7.3.1 Daily Maintenance of Battery Module	
7.3.2 Announcements for Battery Module Replacement	
7.4 Troubleshooting	

7.4.1 Common Fault

7.4.2 UPS Unit Operation Screen and Buzzer Fault

7.4.3 System or Lithium-ion Module Faults

7.5 Emergency Response to System Faults

8 Package, Transportation and Storage

8.1 Package

8.2 Transportation

8.3 Storage

A Technical Specifications

B Acronyms and Abbreviations

1. Safety Description

1.1 Safety Announcements

1.1.1 Statement



Before operation, please read the announcements and operation instructions in this section carefully to avoid accident.

Local laws, regulations and codes should be observed during installation, operation and device maintenance.

The promptings in the user manual, such as "**DANGER**", "**WARNING**", "**CAUTION**", etc. **DO NOT** include all safety announcements. They are just the supplement of safety announcements while operating.



Any device damage caused by violating the general safety operation requirements or safety standards of design, production, and usage will be out of Rehiko's warranty range.

1.1.2 General Requirements



High temperatures and voltages are present inside the equipment. When operating the device, please strictly observe all warning labels and operating instructions on the machine and in the manual.



Touching high voltage, mains directly or by wet objects can be fatal.



Please do not put finger or tool into the rotating fans to avoid human injury or device damage.



Damaged device or device fault may cause electric shock or fire!

- Before performing any work on the device, please check whether there is no damage or danger in the device visually.
- Check whether the connection with other external devices or circuits is safe.

1.2 Electrical Safety

1.2.1 Input/Output



The battery wiring must be performed on the basis of the provision of system. Nonstandard operation will damage the UPS unit and battery module, even endanger the human safety.

 **CAUTION**

The input and output of the device is dangerous high voltage, which may endanger human safety if operated improperly. Please read the user manual carefully before installing, operating, and pay attention to the caution instructions. Do not dismantle the case unless authorized professional serviceman.

 **CAUTION**

When UPS is powered off, there may still be dangerous voltage at its input. It is recommended to install an external reverse power feed protection device. Please consult the manufacturer for specific model selection and support. The output of system may exist dangerous voltage, so, it is necessary to set warning labels around the system, the warning label should include following content: before wiring construction, please disconnect the system.

1.2.2 Grounding Requirements

 **WARNING**

High leakage risk! Device must be grounded before performing electrical connection. The grounding terminal must be connected to ground.

- When install device, it must be grounded first.
- Device should be connected to the protection earth permanently. Before operation, please check the electrical connection to ensure the device is grounded reliably.
- When dismantle device, the grounding wire must be removed at last.
- Don't damage the grounding conductor.

1.2.3 Wiring Requirements

 **CAUTION**

Power wires and other wiring should be routed away from areas where they may be stepped on or tripped over.

1.2.4 Anti-static Requirements

 **CAUTION**

Static electricity generated by the human body may cause damage to sensitive devices on the printed board. Before contacting sensitive components, wear an anti-static bracelet and ground the other end of the bracelet well.

1.3 Operation & Maintenance Requirements

 **WARNING**

To avoid danger or unnecessary loss, the device should be kept far away from the electrical equipment which may cause sparks. If lithium-ion battery module catches fire, please use a fire extinguisher which is suitable for lithium-ion batteries.

 **DANGER**

To avoid lethal risk, do not touch terminals or conductors connected to positive or negative feeds.

 **DANGER**

When the device needs to be moved, rewired or serviced, all electrical connections must be disconnected to isolate the power input and wait until the system has finished powering down (≥ 10 min) before proceeding with the operation, otherwise the outputs may still be electrically charged and there will be a risk of electric shock!

Device maintenance is to be performed by authorized professionals. Non-authorized maintenance professionals are advised not to open the outer cover of the system, as there is a risk of electric shock and the resulting equipment or product failure is not covered by the warranty.

1.3.1 Lithium-ion Battery Module Requirements

 **CAUTION**

Please use the specified type battery module! Random use of a battery module other than the specified model will damage the system.

 **WARNING**

Mixing of battery modules from different manufacturers is strictly prohibited.

 **DANGER**

Do not open or damage the battery module, otherwise it may cause electric shock hazard, short circuit and fire.

2 Overview

2.1 Product Intro

The Rehiko EW 6000-Li is a system solution that integrates a UPS unit, battery module and power distribution module. The system is characterized by high efficiency and high power density, fully protecting critical loads. The battery module is safe and reliable and supports online hot-swapping. The integrated system adapts UPS units of different powers and different battery module types to realize diversified configurations and meet customers' multi-combination power backup needs. The system application scenarios are shown in the picture below.

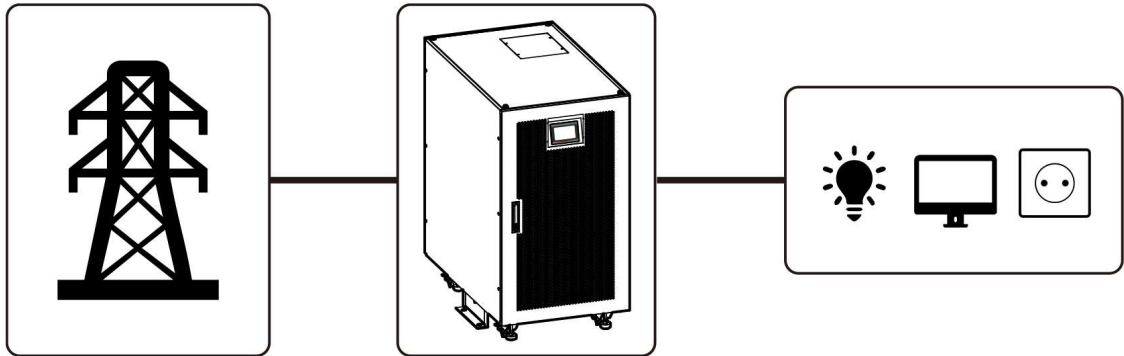

Figure 2.1: System application scenarios

2.1.1 Name Plate Details

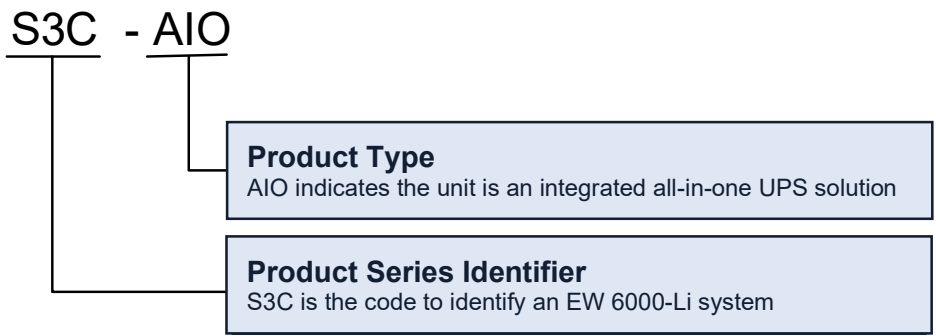

Figure 2.2: Name Plate Details

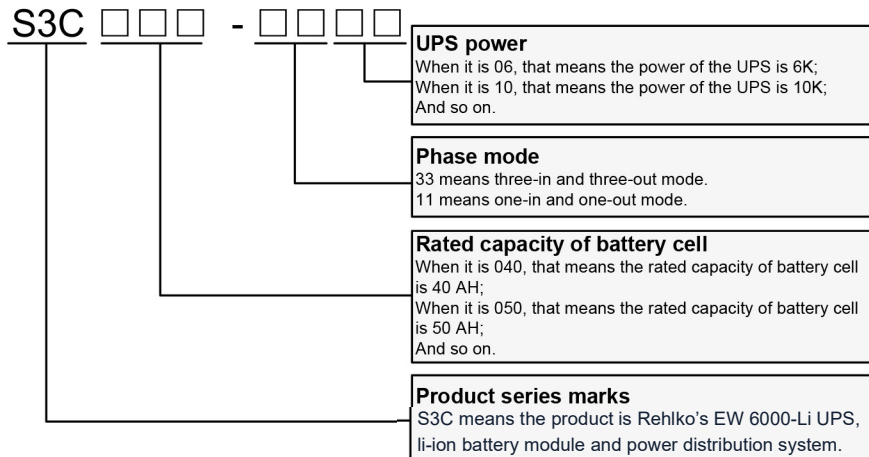

Figure 2.3: Model meaning

The system can be configured according to the actual needs, the products configuration details are shown in the table below.

Table 2.1: Configuration details

Name	Model	UPS power	No. of lithium-ion battery pack
11 series EW 6000-Li system	S3C040-1106	6K	40AH : 1~8
	S3C050-1106		50AH : 1~8
	S3C100-1106		100AH : 2~4
	S3C040-1110	10K	40AH : 1~8
	S3C050-1110		50AH : 1~8
	S3C100-1110		100AH : 2~4
33 series EW 6000-Li system	S3C040-3310	10K	40AH : 1~8
	S3C050-3310		50AH : 1~8
	S3C100-3310		100AH : 2~4
	S3C040-3315	15K	40AH : 2~8
	S3C050-3315		50AH : 2~8
	S3C100-3315		100AH : 3~4
	S3C040-3320	20K	40AH : 2~8
	S3C050-3320		50AH : 2~8
	S3C100-3320		100AH : 4
	S3C040-3330	30K	40AH : 3~8
	S3C050-3330		50AH : 3~8
	S3C040-3340	40K	40AH : 4~8
	S3C050-3340		50AH : 4~8

2.1.2 Feature

Safety

- Full breaker design improves system reliability.
- The ultra-wide voltage input range of the UPS unit is perfectly compatible with the generator, which can be adapted to different grid environments and improve the reliability of the load power.
- When the battery module fault, it will exit automatically, without expanding the fault.
- Battery modules with module-level fire protection, fast and accurate fire extinguishing, non-proliferation.
- Battery module online array insulation detection, early warning battery module insulation failure.

Smart

- UPS unit + battery module information is centrally displayed, one screen controls the whole situation, and the touch screen adopts elevation angle design to enhance the user experience.
- Advanced DSP control technology, accurate and rapid data processing, with rapid fault self-diagnosis and processing capabilities, perfect self-protection function, higher intelligence.
- Battery module adaptive power output, intelligent regulation, support for module-level mixing of old and new batteries, flexible battery module configuration to meet different backup time requirements.

Simple

- UPS unit + battery module integrated design, high power density, more compact size, user space cost reduction.
- UPS unit and battery module design life matching, the whole life cycle without replacing battery module, reducing maintenance costs.
- Mounted on wheels for flexible positioning and rapid deployment.
- Lithium battery modular parallel design, supporting online staged expansion, battery module hot-swap and maintenance times measured in minutes not hours or days.

2.2 Work Principle

The work principal diagram of system is as shown below.

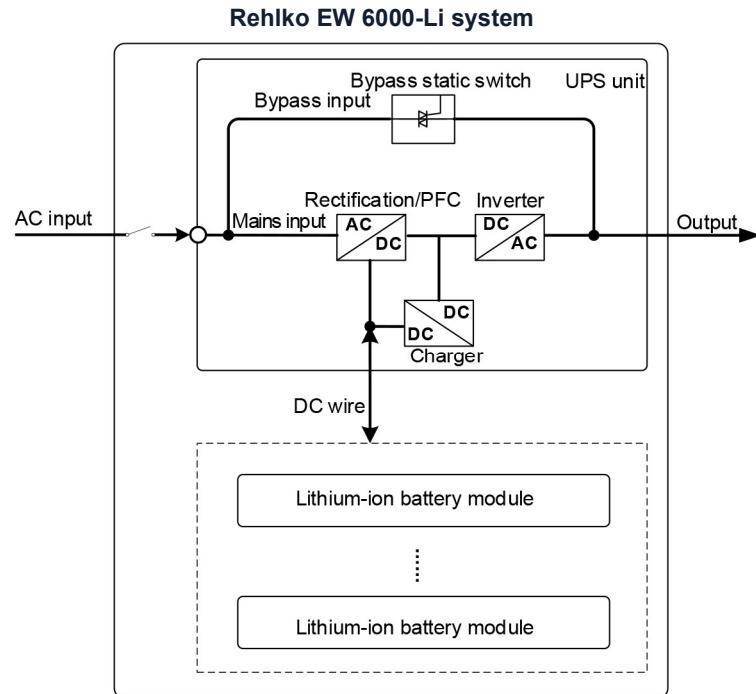

Figure 2.4: Work principal diagram of 11 series EW 6000-Li system

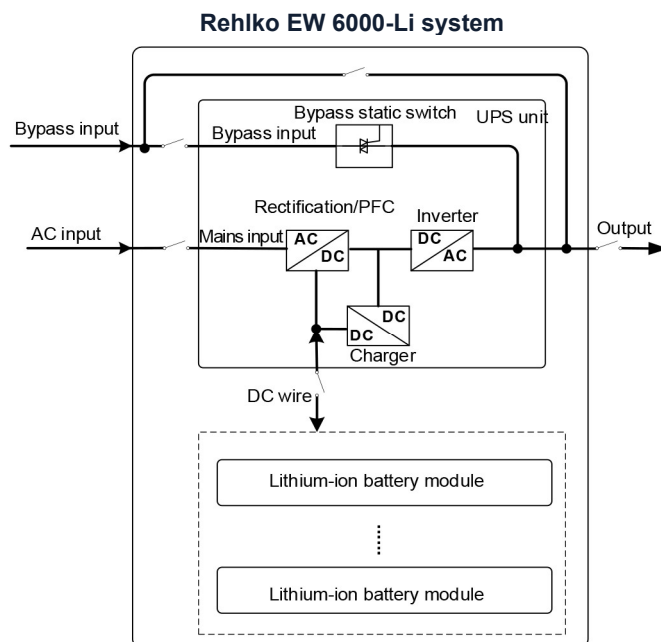

Figure 2.5: Work principal diagram of 33 series EW 6000-Li system

2.3 Appearance and Structure

2.3.1 Appearance

NOTE

Each model of the system has the same appearance and dimensions, and the appearance of the system is shown below.

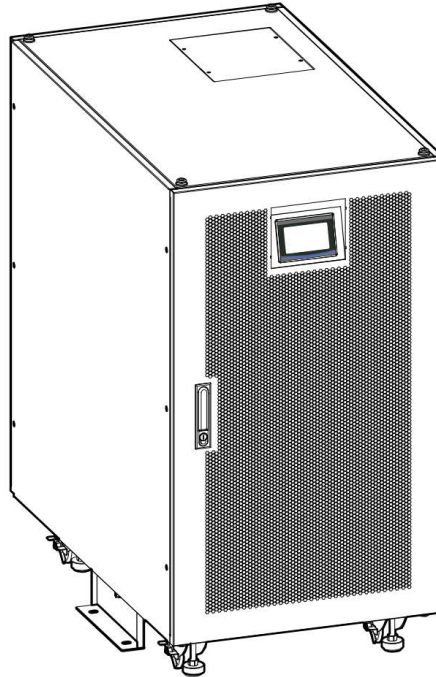

Figure 2.6: Appearance

Structure Layout

NOTE

11 series EW 6000-Li system without assembled power distribution modules, 33 series with 10-20K UPS systems are assembled with 20K distribution modules, 33 series with 30-40K UPS systems are assembled with 40K distribution modules. As shown in the picture below.

The following diagrams are all illustrated with the system fully equipped with battery modules as an example. Users can configure the number of battery modules according to actual needs.

11 series EW 6000-Li system

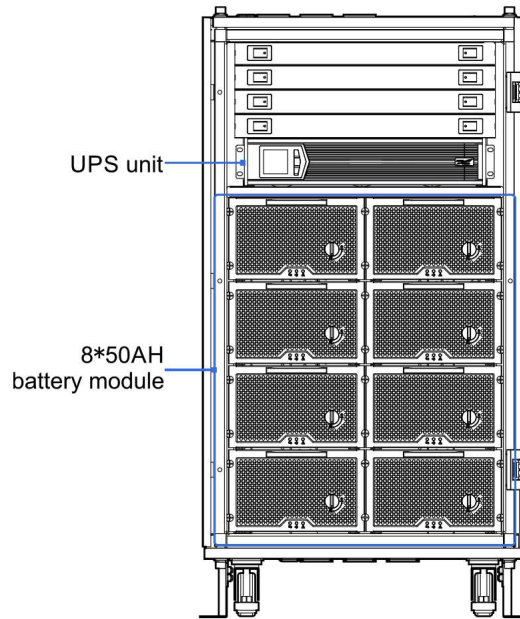

Figure 2.7: Layout of 11 series EW 6000-Li system

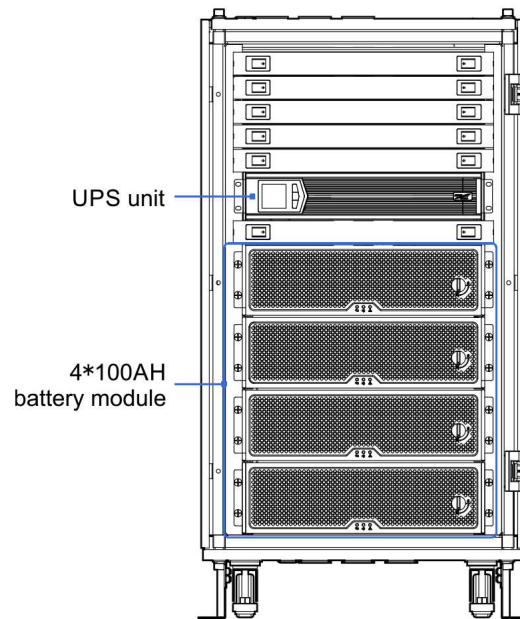

Figure 2.8: Layout of 11 series EW 6000-Li system

33 series EW 6000-Li system

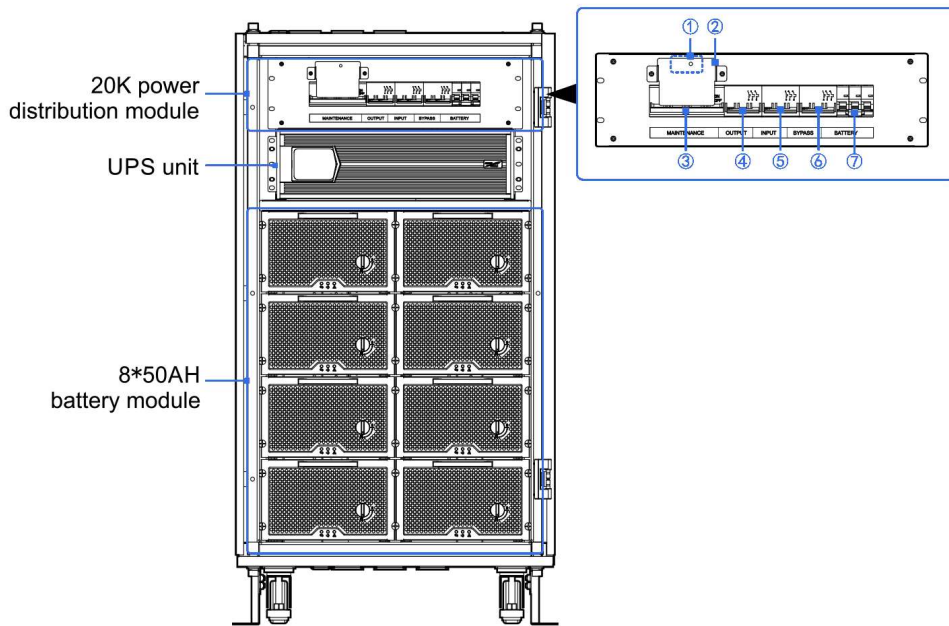

Figure 2.9: Layout of 33 series EW 6000-Li system

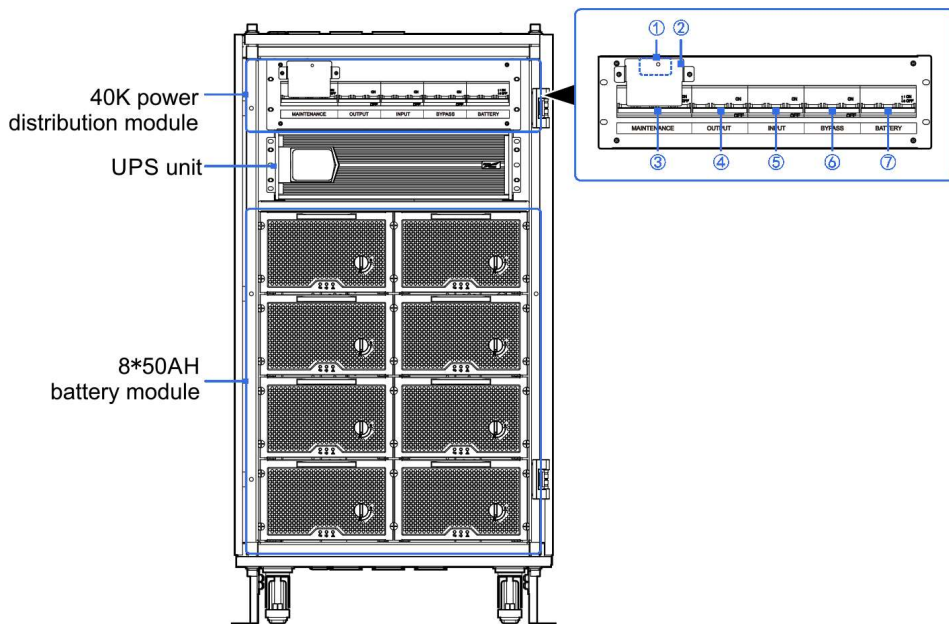

Figure 2.10: Layout of 33 series EW 6000-Li system

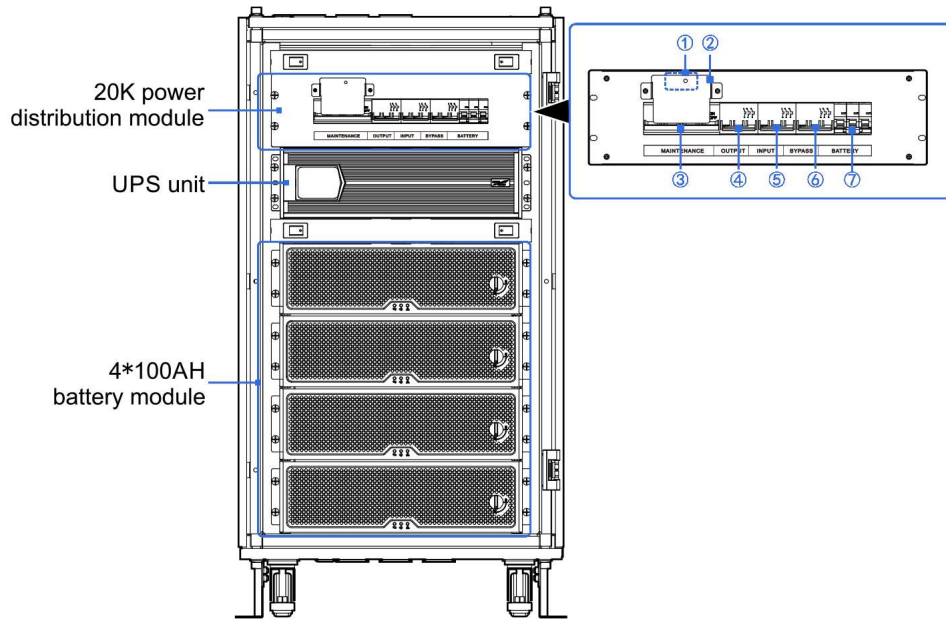

Figure 2.11: Layout of 33 series EW 6000-Li system

Table 2.2: Distribution module description

No.	Name	No.	Name	No.	Name
①	Maintenance bypass status detection breaker	④	AC output breaker	⑦	Battery breaker
②	Maintain bypass breaker protection plate	⑤	AC input breaker	-	-
③	Maintenance bypass breaker	⑥	Bypass breaker	-	-

2.3.3 Communication Method

NOTE

The location of the communication interface is the same for different models, as shown below.

The system is equipped with RS485 external port, EPO port and built-in SNMP card port, the location of the communication interface as shown below.

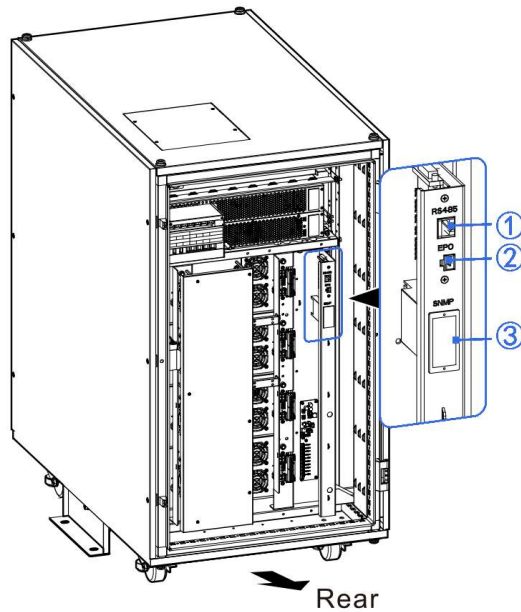

Figure 2.12: Communication port location

RS485 port

RS485 interface is the external communication interface, the interface position is shown in ① of 0, the specific interface definition see 0. Specific installation see 04.3 Communication.

EPO port

EPO position is shown in ② of 0, EPO devices are configured by the customer. Specific installation please see 04.3 Communication.

SNMP card port

SNMP card position is shown in ③ of 0, Users can install according to the actual situation, the installation steps are detailed in the 03.6 SNMP Card Installation (Optional). SNMP card can be managed remotely over the network, please refer to the corresponding SNMP card user manual for details.

Lithium-ion Battery Module

Lithium-ion battery module contains three models of 40AH/50AH/100AH, the appearance is as shown below.

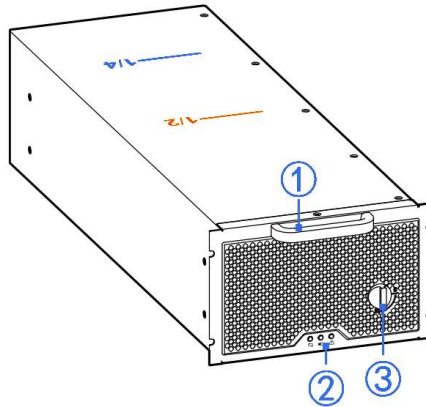

Figure 2.13: 40AH/50AH lithium-ion battery module appearance

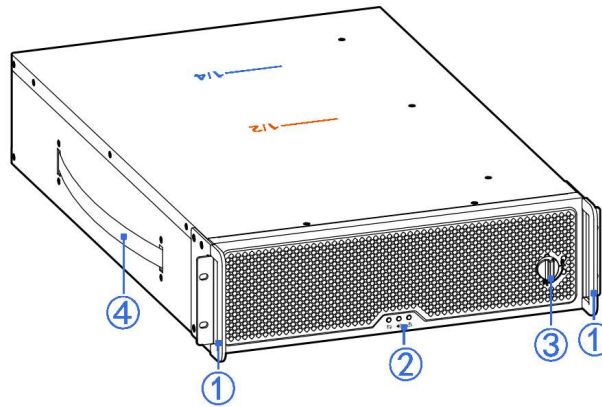

Figure 2.14: 100AH lithium-ion battery module appearance

Table 2.3: Component illustration of lithium-ion battery module

No.	Name	No.	Name
①	Front handle	③	ON/OFF knob
②	Indicators	④	Handle

 **NOTE**

At the top of the battery module, there is position marks. The yellow "1/2" means half of the module. The red "1/4" means quarter of the module.

When the ON/OFF knob stay in  status, the module is not locked with cabinet, and the module can be dismantled.

When the ON/OFF knob stays in  status, the module is locked with cabinet, and the module cannot be dismantled.

 **CAUTION**

When the ON/OFF knob is stays in  status, the module starts to output automatically, and the output is with DC voltage.

Table 2.4: Indicator illustration



























Mark	Name	Colour	Mark	Name	Colour
	Run indicator	Green		Fault indicator	Red
	Alarm indicator	Yellow	-	-	-

Table 2.5: Indicator status description

Indicator Status	Run	Alarm	Fault	Indicator Status	Run	Alarm	Fault
Charge				Module alarm	-*		
Discharge				Communication abnormal	-		-
Sleep				Module protect			
OFF				Battery abnormal			



 **NOTE**

*** means that the indicator stay in any status.

 ,  ,  means that the corresponding indicator is on.

 ,  ,  means that the corresponding indicator flickers once every 1 second.

 means that the alarm indicator flickers once every 3 seconds.

 ,  ,  means that the corresponding indicator is off.

Heat Dissipation Description

The equipment adopts the cooling method of "front air inlet and rear air outlet" to discharge the heat generated inside. In order to make the equipment work in a better state, the installation environment should be well ventilated and ensure that the air inlet has enough air intake.

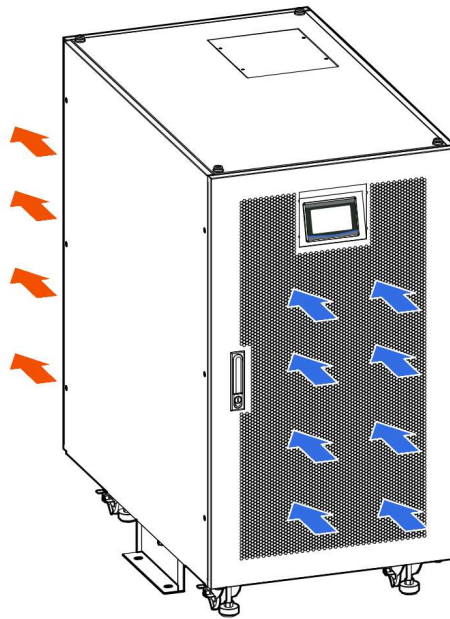

Figure 2.15: Heat dissipation

 **CAUTION**

Ensure that the air inlet and outlet holes of the cabinet and the front of the fan (the fan is located at the front of the UPS unit and at the rear of the battery module) are not obstructed by other objects to maintain good ventilation.

3. Installation



Only authorized personnel (professionally trained and qualified to work with high voltage, alternating current, etc.) can install the device.

The device is only suitable for installation on concrete or non-flammable surfaces.

3.1 Installation Process

The installation process of the system as shown below.

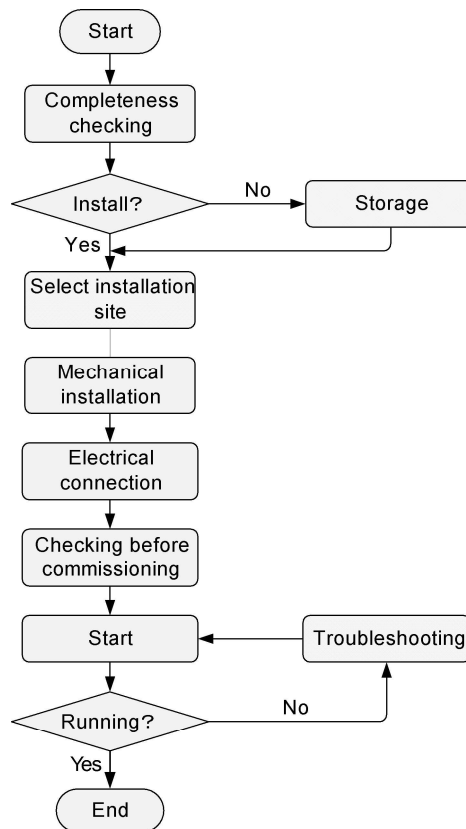

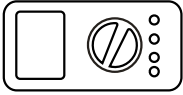

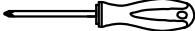
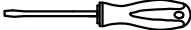

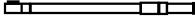



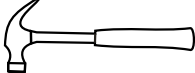
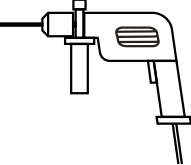
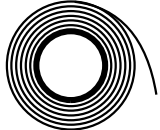
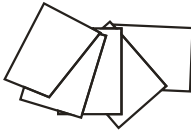
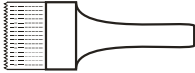
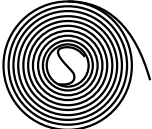
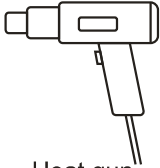

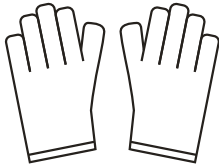
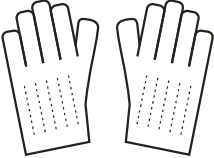
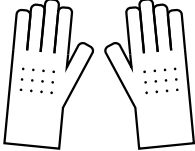



Figure 3.1: Installation process

3.2 Installation Preparation

3.2.1 Installation Tools

Tools			
			
Clamp meter	Multi-meter	Label paper	Phillips screwdriver
			
Flat-headscrewdriver	Socket wrench	Adjustable wrench	Torque wrench
			
COAX crimping tool	Diagonal pliers	Wire stripper	Claw hammer
			
Hammer drill	Insulation tape	Cotton cloth	Brush
			
Heat shrink tubing	Heat gun	Electrician's knife	Protective gloves
			
ESD gloves	Insulated gloves	Hydraulic pliers	Cable tie

 **CAUTION**

The installation tools must be with insulation protection to avoid electric shock.

3.2.2 Installation Environment

 **DANGER**

DO NOT install the device in the place where has inflammable, explosive gas or smog, and any operation cannot be done under this circumstance.

Performing operation for any electronic equipment in the environment where has inflammable gas will cause extremely danger. Please use and store the device within the environment requirements mentioned in the manual.

The operation environment may influence the life span and reliability of device. So, please avoid using device in following environment:

- Do not use the system in direct sunlight, rain, humid environments, near heat sources or places with metal conductive type dust.
- The normal operating temperature of the system is $-5^{\circ}\text{C}\sim+40^{\circ}\text{C}$, relative humidity is 0%RH~95%RH, no condensation (Recommended operating temperature is $20^{\circ}\text{C}\sim25^{\circ}\text{C}$, humidity is controlled at about 50%, battery module stops charging when it is below 0°C).
- The device should be placed on a flat surface without vibration and with no more than 5° vertical inclination.
- The install place should be with good ventilation. Poor ventilation can lead to higher temperature inside, shortening the life of its internal components and thus affecting the life of the device.
- The used altitude should be within 2000m, if the used altitude exceeds 2000m, it needs to reduce the rated power according to IEC 62040-3 to use.

 **CAUTION**

The optimum operating temperature of battery module is $20^{\circ}\text{C}\sim30^{\circ}\text{C}$. When working in the environment where is higher than 30°C , it will shorten the service life of battery, when working in the environment where is lower than 20°C , it will shorten the backup time of battery module.

3.2.3 Installation Space

The front and rear door panels of the device should be kept at least 800mm away from the wall or other adjacent devices, and the top should be kept at least 500mm away from the ceiling to ensure ventilation and heat dissipation, as shown in the picture below.

 **CAUTION**

Do not cover the ventilation holes on the front and rear doors of the device. This can affect the device's ventilation and heat dissipation, leading to increased internal temperature and reduced system lifespan.

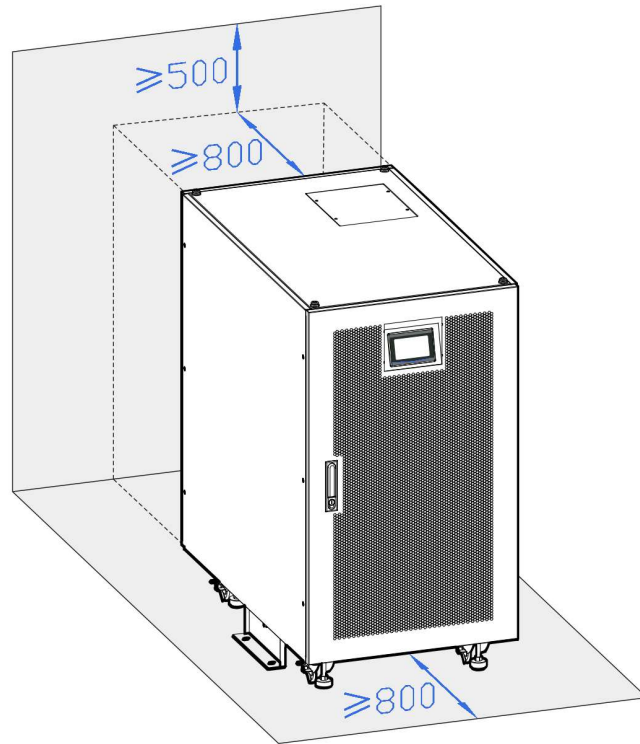

Figure 3.2: Installation space (unit: mm)

3.3 Transport and Unpacking

3.3.1 Transporting



The system must be transported by trained professionals.

While transporting, please move gently and avoid impacting or dropping.

If the system needs to be stored for long time after unpacking, it is suggested to pack the device by original plastic bag.

The system can be transported by forklift (see 0) and manual forklift (see 0). When lifting the device, the device's centre of gravity should be at the centre of the forklift arm. Keep the devices moving slowly and stably.

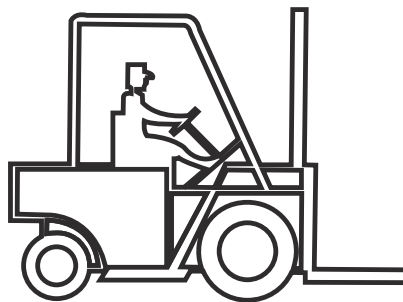

Figure 3.3: Forklift transportation

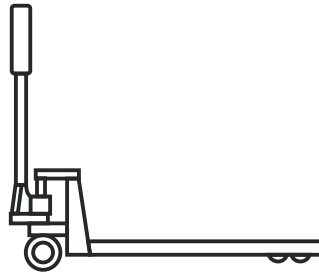

Figure 3.4: Manual forklift transportation

 **CAUTION**

During transporting, please take care and avoid impact or falling off.

During moving, keep the system vertical and do not put down or uplift suddenly.

3.3.2 Unpacking

Step 1: Check if the package appearance is in good condition and if there is any damage caused by transportation. If damaged, please inform the carrier immediately.

Step 2: Transport the system to assigned site.

 **CAUTION**

To avoid tilting during transportation, keep the system's centre of gravity at the centre of forklift arms and keep the forklift arm go beyond the wooden tray.

1. The cabinet has rollers, when removing the positioning parts of the cabinet, the cabinet should be guarded against sliding. When removing the wooden brackets, enough labour should be ensured.
2. The strength of the rollers only meets the requirement of moving the unloaded cabinet on a flat surface, and the rollers may not be effective when moving on an uneven surface.

Step 3: Unpack the external package, and take out the fittings, the unpacked appearance as shown in the below.

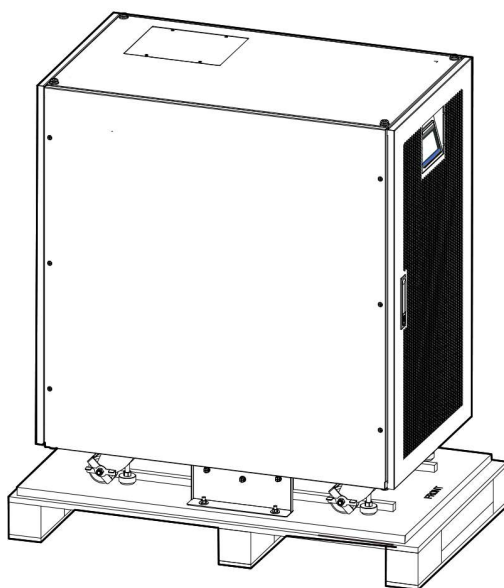

Figure 3.5: Unpacked appearance

Step 4: Check the system.

- Inspect the appearance and check if there is any damage caused by transportation. If damaged, please inform the carrier immediately.
- Refer to the packing list and check if the accessories model is complete and proper. If the accessories are missed or the model is wrong, please record it and contact our company or local agency.

Step 5: After confirming that the device is intact, loosen the ten (5 on the left and 5 on the right) bolts on the bottom of the system by wrench, and remove the bolts and the support brackets on both sides, as shown in the picture below.

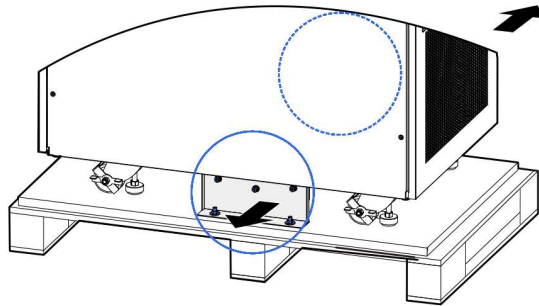

Figure 3.6: Remove support bracket

 **NOTE**

When removing the support bracket, please take care to retain the six M8 bolts between the support bracket and the device.

Step 6: Insert the oblique board into the front port of the wood bracket. After the oblique board and wooden bracket have been secured, rotate the bottom support foot of the system clockwise to make sure that the support foot is at least 30mm away from the wood pallet, which prevents the support foot from contacting the wood pallet or the ground during device movement.

Step 7: Then slip the system along the oblique board to ground slowly.

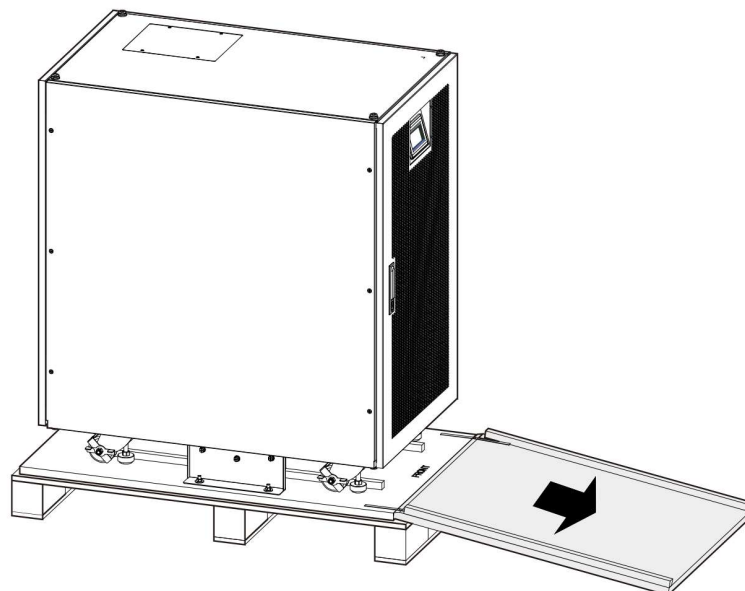

Figure 3.7: Move the device to the ground

 **NOTE**

When moving, at least two people are required to assist in controlling the speed and movement direction.

3.4 System Installation

Step 1: Determine and plan the installation position according to the device size (as shown in the picture below) and install space requirement (see 03.2.3 Installation Space).

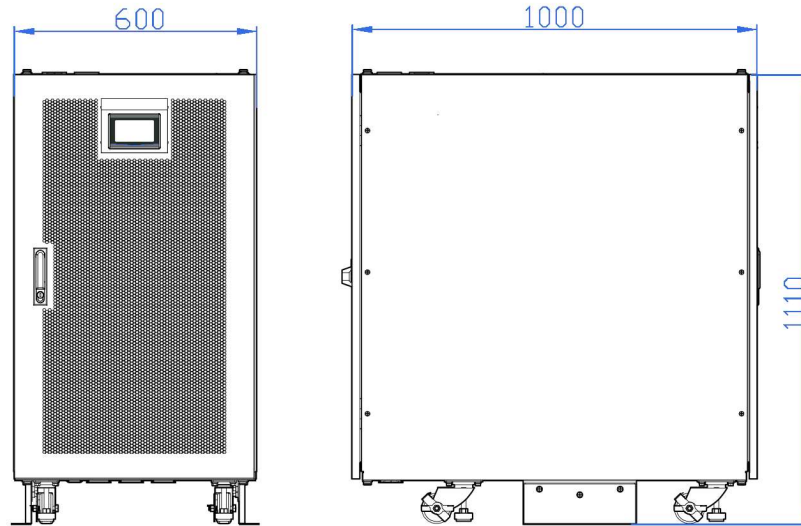

Figure 3.8: Outer dimension (unit: mm)

Step 2: Drill four $\phi 12$ holes on the ground by impact drill according to the installation holes size of pedestal (no additional drilling is required if there are existing bolt holes in the floor or other appropriate fixing base for fixing), as shown in the picture below.



If the system is not installed with a support plate, the equipment may tip over in the event of an earthquake or impact.

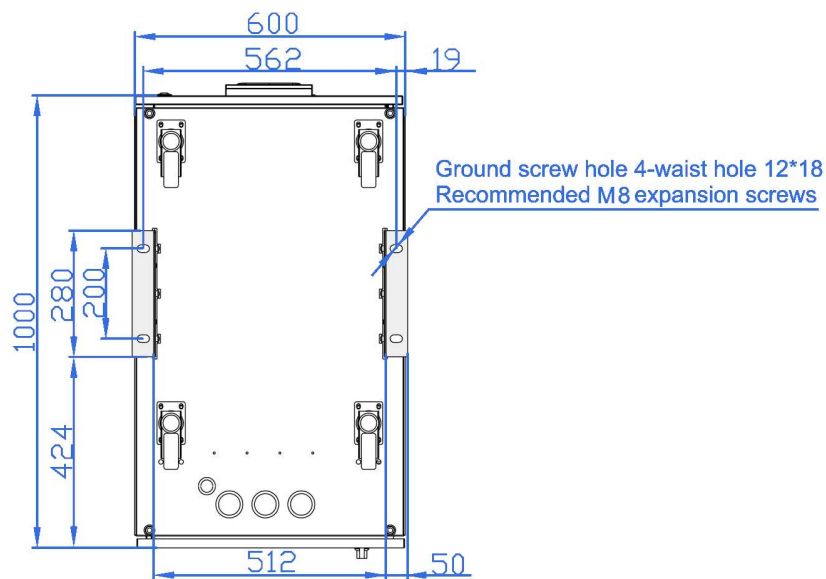

Figure 3.9: Installation holes size (unit: mm)

Step 3: Install the expansion bolts. Install the four M8 expansion bolts into the drilled mounting holes as shown below.

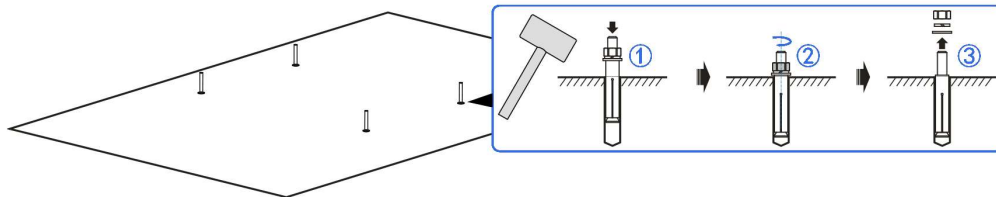

Figure 3.10: Install the expansion bolts



The expansion tube must be knocked into the installation holes. The expansion tube cannot be higher than the ground, which is to avoid effect the following installation.

The outer height of expansion bolts should be within the range of 30-50mm.

Step 4: Place the support bracket on the floor where the expansion bolts have been drilled, put on the washers, spring washers and nuts, then pre-lock the bolts. As shown below.

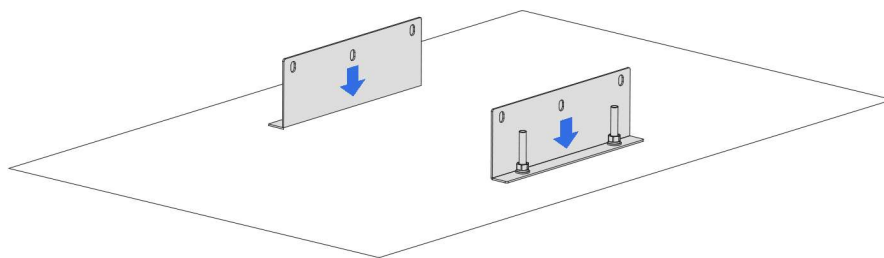

Figure 3.11: Support bracket installation

Step 5: Push the device between the support brackets and pre-lock the device to the brackets with the six M8*20 bolts retained when the brackets were removed, as shown below.

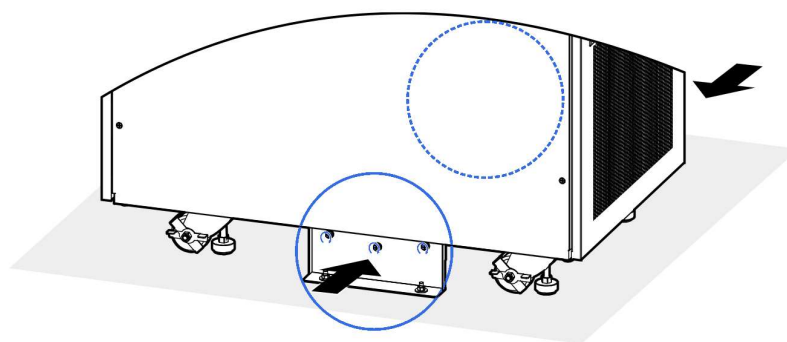

Figure 3.12: System fixed

Step 6: Rotate the support feet counterclockwise until the four universal wheels on the bottom of the system are suspended. Tighten the pre-locked bolts on the support bracket to secure the support bracket to the system.

3.5 Lithium-ion Battery Module Installation

NOTE

The lithium-ion battery module is packed by itself and needs to be installed on site.

Step 1: Take out the module from package.



CAUTION

- The battery module is heavy (the weight of 40AH battery module is more than 35kg, the weight of 50AH battery module is more than 38kg, the weight of 100AH battery module is more than 50kg), when transporting, the module needs to be carried by several person.
- Before transporting the battery module, please ensure the ON/OFF knob stay in  status to avoid the module power on by itself and output dangerous voltage.
- The battery module is dangerous, during transporting, please carry it gently and avoid knocking or falling.

Step 2: Open the front door of the system.

Step 3: Insert the module from bottom to top successively, and fasten the module by screws, as shown in the picture below.

CAUTION

- Before installing, ensure that the ON/OFF knob of module stay in  status (as shown in the picture below).
- While inserting the module, DO NOT overexert to avoid damaging the rear connectors.
- After finish the installation, keep the ON/OFF knob stay in  status to avoid the danger of electric shock. When the system debugging, the module can be started.

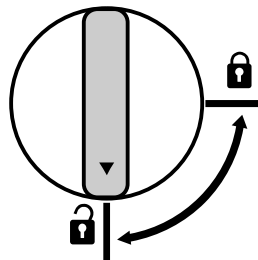

Figure 3.13: Unlock status of ON/OFF knob

- 40AH/50AH battery module

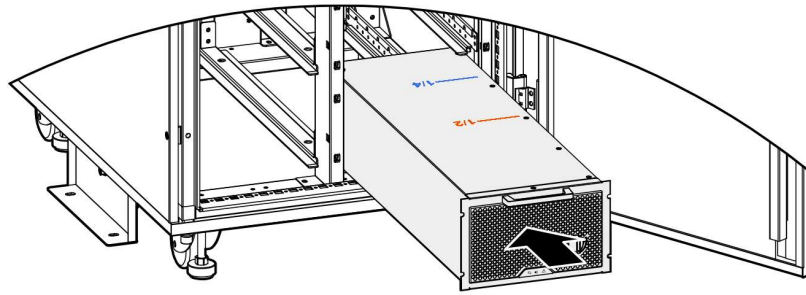

Figure 3.14: Install 40AH/50AH battery module

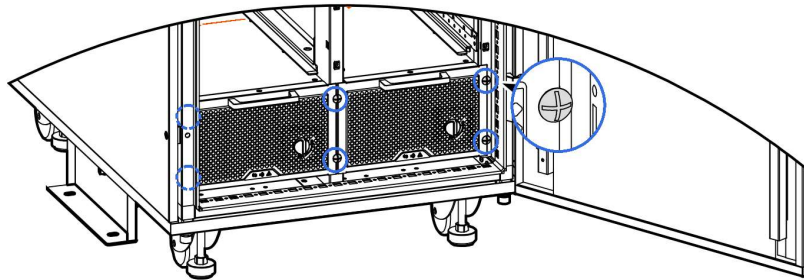

Figure 3.15: Fix 40AH/50AH battery module
100AH battery module

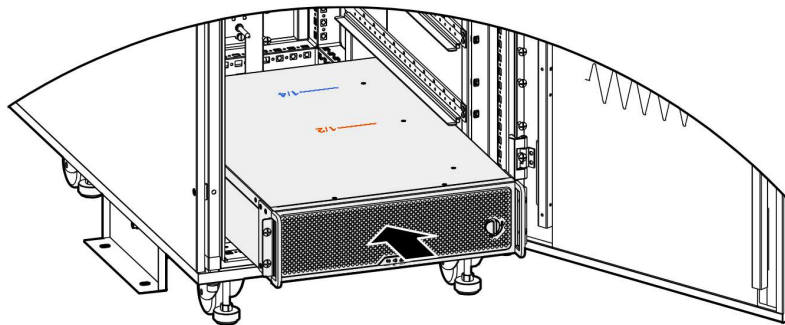

Figure 3.16: Install 100AH battery module

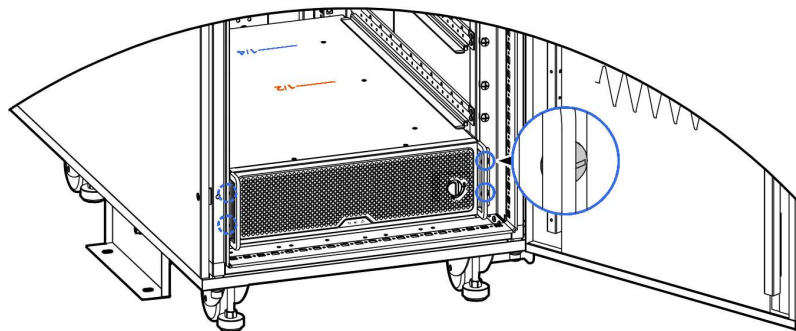



Figure 3.17: Fix 100AH battery module

 **NOTE**

When the battery module is not fully configured, install the module from bottom to top, and install blank panel to the position where with no module.

 **CAUTION**

If the battery module needs to be dismantled to adjust, please do as following procedure:

1. Screw the ON/OFF knob to  status.
2. Pull out the module by handles and pay attention to the top silkscreen. The yellow "1/2" means half of the module has been pulled out, the operation speed should be slow. The red "1/4" means for quarter of the module is in the cabinet, at this time, move the module by two hands or two person and pay attention to the possible danger of falling.

3.6 SNMP Card Installation (Optional)

 **NOTE**

When the system is shipped with the optional SNMP card ordered from the factory, the SNMP card will be shipped mounted directly into the slot on the rear of the system.

If no SNMP card is ordered from the factory, the optional SNMP card will be shipped separately and need to be installed in the field.

 **CAUTION**

- Before installation, the device must be completely powered down.
- The communication ports of different models of the system are in the same direction, as shown in the picture below.
- Please pay attention to the direction of insertion when plugging, to avoid excessive force resulting in damage to the port.

Users can install the SNMP card according to the actual situation. Before installing the SNMP card, users need to remove the SNMP interface sealing plate at the rear of the system, and then insert the SNMP card into the slot, the specific operation is shown in the picture below.

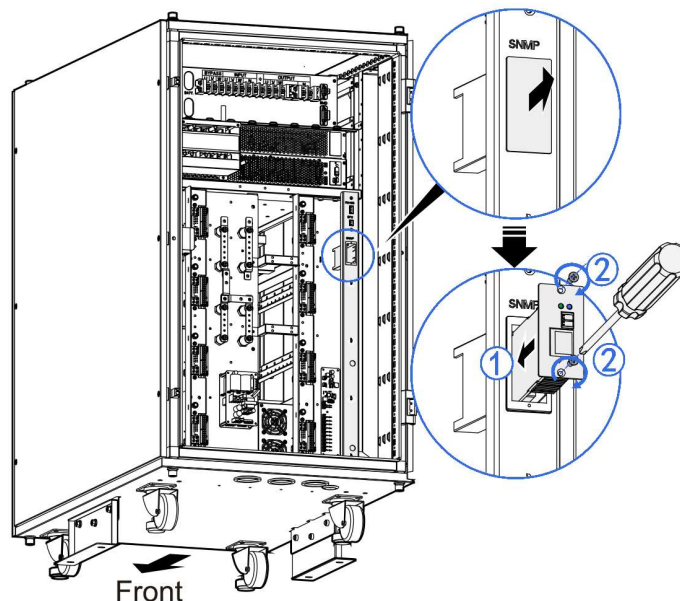

Figure 3.18: SNMP installation

4. Electrical Connection

4.1 Cable & Breaker Preparation

4.1.1 Switch Selection

Users can select the AC input and output cables, DC input cables and corresponding switch specifications for equipment connection according to the maximum steady state operating current of the system.

Table 4.1: Steady-state phase current of EW 6000-Li system

Item		AC input (A)	Bypass input (A)	DC input (A)	AC output (A)
11 series system (with 6K UPS)	11 mode	40	25	36	25
11 series system (with 10K UPS)	11 mode	61	41	59	41
33 series system (with 10K UPS)	33 mode	18	15	29	15
	31 mode	18	46	29	46
33 series system (with 15K UPS)	33 mode	26	23	44	23
	31 mode	26	68	44	68
33 series system (with 20K UPS)	33 mode	35	31	58	30
	31 mode	35	91	58	91
33 series system (with 30K UPS)	33 mode	59	45	83	45
33 series system (with 40K UPS)	33 mode	75	61	111	61

4.1.2 Select Wire

For the wire specification of AC input, AC output, rounding wire and terminals, please see the recommended value in the table below.

Table 4.2: Recommended wire specification and terminals of 11 series EW 6000-Li system (wire specification: mm²)

Model \ Item		AC input live wire (L)	AC input neutral wire (N)	AC output live wire (L)	AC output neutral wire (N)	Grounding wire (PE)
11 series system (with 6K UPS)	Wire	6*1	6*1	6*1	6*1	6*1
	Terminal	RV5.5-6	RV5.5-6	RV5.5-6	RV5.5-6	RV5.5-6
11 series system (with 10K UPS)	Wire	10*1	10*1	10*1	10*1	10*1
	Terminal	RNBS8-6	RNBS8-6	RNBS8-6	RNBS8-6	RNBS8-6

Table 4.3: Recommended wire specification and terminals of 33 series EW 6000-Li system (33 mode) (wire specification: mm²)

Model \ Item		AC input live wire (U/V/W)	AC input neutral wire (N)	Bypass input live wire (U/V/W)	AC output live wire (U/V/W)	AC output neutral wire (N)	Grounding wire (PE)
33 series system (with 10K UPS)	Wire	4*3	4*1	4*3	4*3	4*1	4*1
	Terminal	RV3.5-6	RV3.5-6	RV3.5-6	RV3.5-6	RV3.5-6	RV3.5-6
33 series system (with 15K UPS)	Wire	6*3	6*1	6*3	6*3	6*1	6*1
	Terminal	RV5.5-6	RV5.5-6	RV5.5-6	RV5.5-6	RV5.5-6	RV5.5-6
33 series system (with 20K UPS)	Wire	10*3	10*1	10*3	10*3	10*1	10*1
	Terminal	RNBS8-6	RNBS8-6	RNBS8-6	RNBS8-6	RNBS8-6	RNBS8-6
33 series system (with 30K UPS)	Wire	16*3	16*1	10*3	10*3	10*1	16*1
	Terminal	RNBS14-6	RNBS14-6	RNBS8-6	RNBS8-6	RNBS8-6	RNBS14-6
33 series system (with 40K UPS)	Wire	16*3	16*1	16*3	16*3	16*1	16*1
	Terminal	RNBS14-6	RNBS14-6	RNBS14-6	RNBS14-6	RNBS14-6	RNBS14-6

Table 4.4: Recommended wire specification and terminals of 33 series EW 6000-Li system (31 mode) (wire specification: mm²)

Model \ Item		AC input live wire (U/V/W)	AC input neutral wire (N)	Bypass input live wire (L)	AC output live wire (L)	AC output neutral wire (N)	Grounding wire (PE)
33 series system (with 10K UPS)	Wire	4*3	10*1	10*1	10*1	10*1	10*1
	Terminal	RV3.5-6	RNBS8-6	RNBS8-6	RNBS8-6	RNBS8-6	RNBS8-6
33 series system (with 15K UPS)	Wire	6*3	16*1	16*1	16*1	16*1	16*1
	Terminal	RV5.5-6	RNBS14-6	RNBS14-6	RNBS14-6	RNBS14-6	RNBS14-6
33 series system (with 20K UPS)	Wire	10*3	25*1	25*1	25*1	25*1	25*1
	Terminal	RNBS8-6	RNBS22-6	RNBS22-6	RNBS22-6	RNBS22-6	RNBS22-6

NOTE

The equipped wires by our company are all passed the national standard or UL certification, the quality is perfect and meets the requirements of safety standard.

The cross-sectional area of the former cable is only for reference when the user is connecting wire with a length of about 5 meters. If the length of the lead wire exceeds 20 meters, the cross-sectional area of the conduct or wire shall be increased.

4.2 System Wiring

WARNING

- Before wiring, make sure that all the external mains front-stage switches of the system are disconnected, and all "ON/OFF" knobs on the battery modules are in the "🔒" state.
- Prohibit wiring with electricity.

CAUTION

When wiring, power cords and other wiring should be routed away from areas where they can be stepped on or tripped over.

NOTE

After the cable is crimped to the terminal, the portion of the cable that is exposed to the terminal needs to be wrapped with insulating tape, as shown in the picture below.

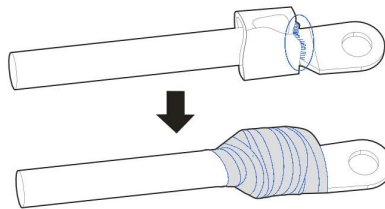

Figure 4.1: Wire insulation

CAUTION

Before wiring, make sure that the system's battery breaker is OFF.

4.2.1 Input & Output Wiring

Step 1: Remove the two screws on the rear door panel of the system and then open the rear door with the key. As shown in the picture below.

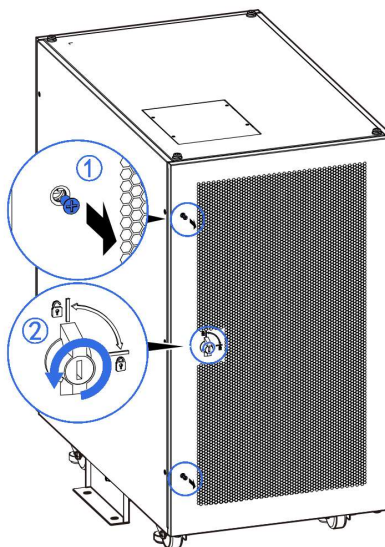

Figure 4.2: Open the system's rear door

Step 2: Draw the wire through the bottom wiring hole on the back of the system.

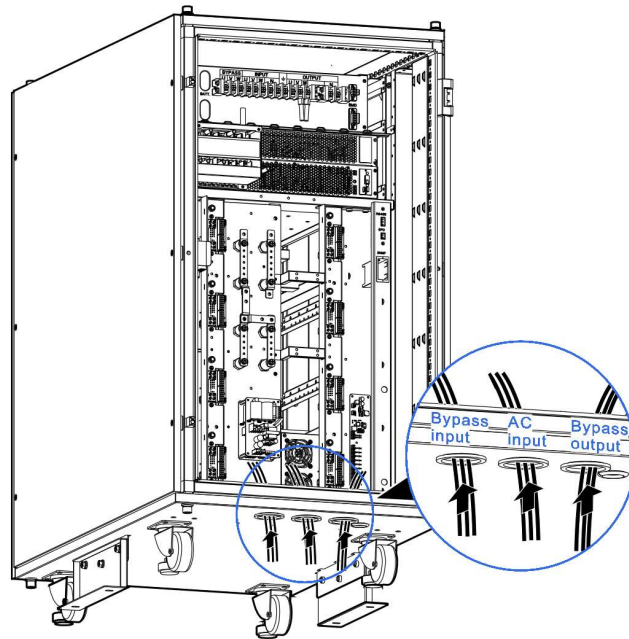

Figure 4.3: Wiring method

Step 3: Connect the system power wires.

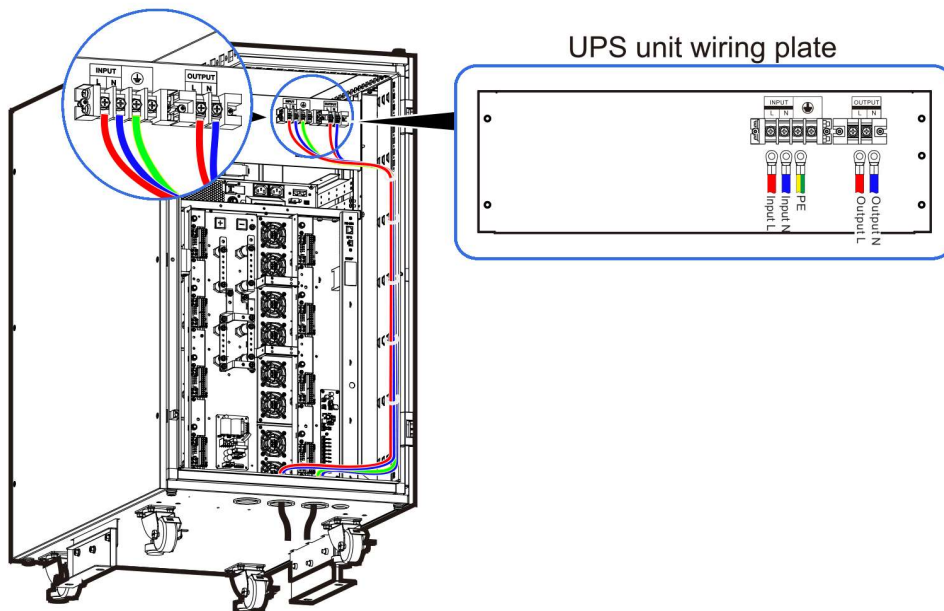

Figure 4.4: 11 series EW 6000-Li system wiring

 **NOTE**

Application of 31 mode: 33 series EW 6000-Li system can apply this mode when assembled with 10K/15K/20K UPS units.

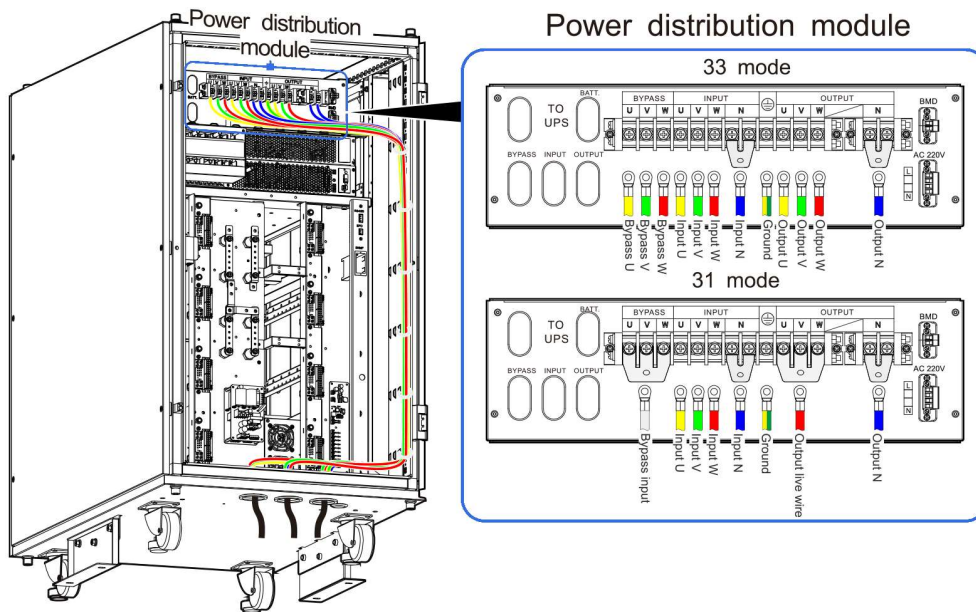

Figure 4.5: 33 series EW 6000-Li system wiring

4.3 Communication

Step 1: Connect the communication cable to the RS485 port and EPO port at the rear of the system after drawing it through the inlet hole at the bottom of the system, as shown in the picture below.

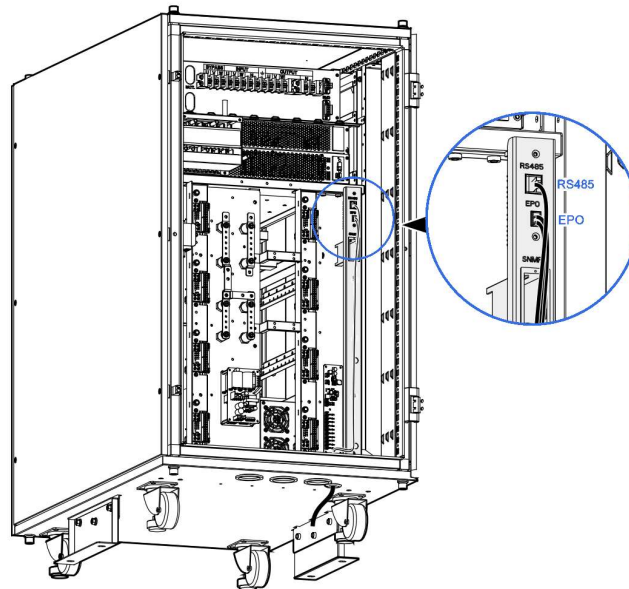

Figure 4.6: Communication wire connection

NOTE

When the EPO interface is open, the system stops output; when the EPO interface is short-circuited, the system is normal. The RS485 port definition and EPO status are as follows.

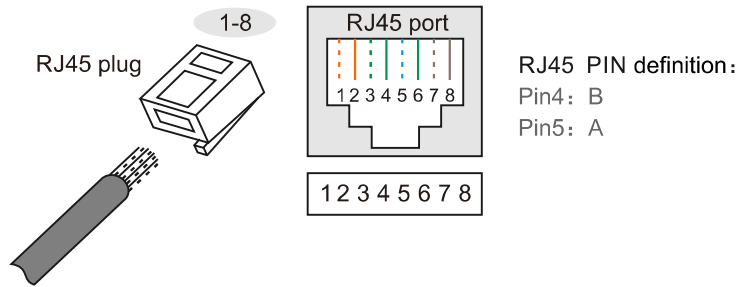

Figure 4.7: RS485 port definition

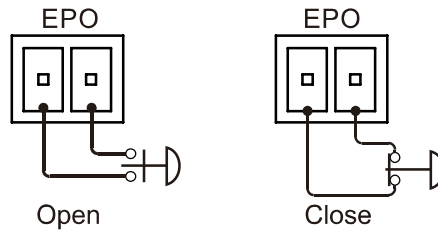

Figure 4.8: EPO status

Step 2: Close the rear door of the system and fix the rear door by screws.

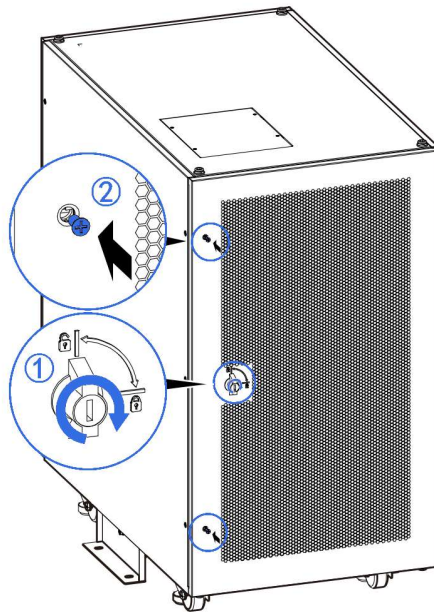

Figure 4.9: lose the rear door

4.4 Check the Installation

To ensure normal operation, after installation and wiring, please check the following items.

Table: 4.5: Check list

No.	Check item	Result
1	Check if the wire colour of system is in accordance with the specification.	Yes <input type="checkbox"/> No <input type="checkbox"/>
2	Check if the wiring of system is firm.	Yes <input type="checkbox"/> No <input type="checkbox"/>
3	Check if the wire connection is firm.	Yes <input type="checkbox"/> No <input type="checkbox"/>
4	Check if the marks of wire are right.	Yes <input type="checkbox"/> No <input type="checkbox"/>
5	Check if the wiring is neat and the wire connection is in accordance with the specification.	Yes <input type="checkbox"/> No <input type="checkbox"/>
6	Check if the installation and wiring of the system is convenient for the reform, expansion and maintenance in the future.	Yes <input type="checkbox"/> No <input type="checkbox"/>
7	Check if there is any other objects inside the cabinet (such as at the back of the module, top of the cabinet, wiring terminals and switch, etc.).	Yes <input type="checkbox"/> No <input type="checkbox"/>

5. Touch Screen Operation

5.1 Menu Hierarchy.

NOTE

The parameters values and other details in the pictures in this chapter are for illustration only. Detailed information should be based on the touch screen of the product.

The voltage displayed on the touch screen is the phase voltage, and the voltage displayed on the nameplate of the device is the line voltage

The menu structure of the touch screen is as shown in the picture below.

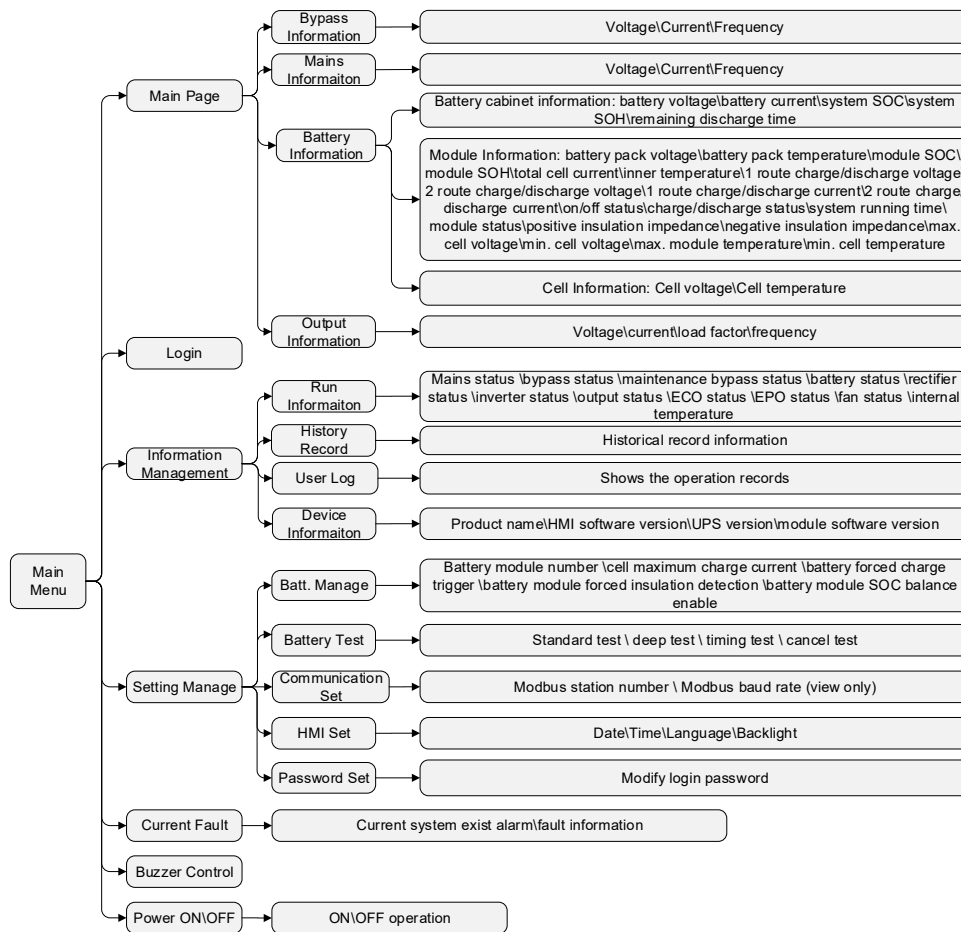

Figure 5.1: Menu structure of the touch screen



The touch screen contains parameters related to the operation of the device. All settings such as modification of parameters must be done by a designated professional. For parameters with unclear meanings, please refer to this book or consult relevant staff of our company. Please do not modify without authorization.

5.2 Main Page

After powering on, the touch screen will enter initialize. Then will enter system monitoring main page after powering on, as shown in the picture below.

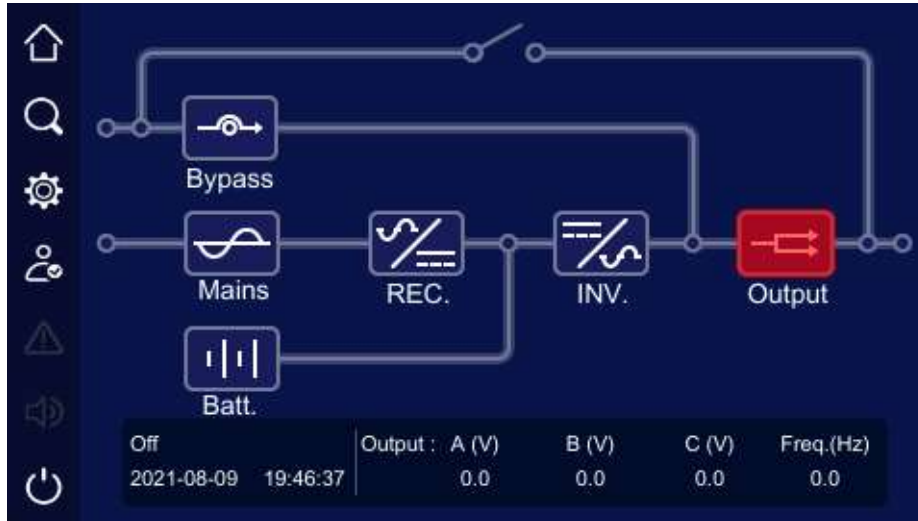

Figure 5.2: Main page

5.2.1 Working Status

There are four main working statuses: mains inverting status, battery inverting status, bypass output status and maintenance bypass output status. The corresponding water lights in the monitoring page are shown in the picture below.

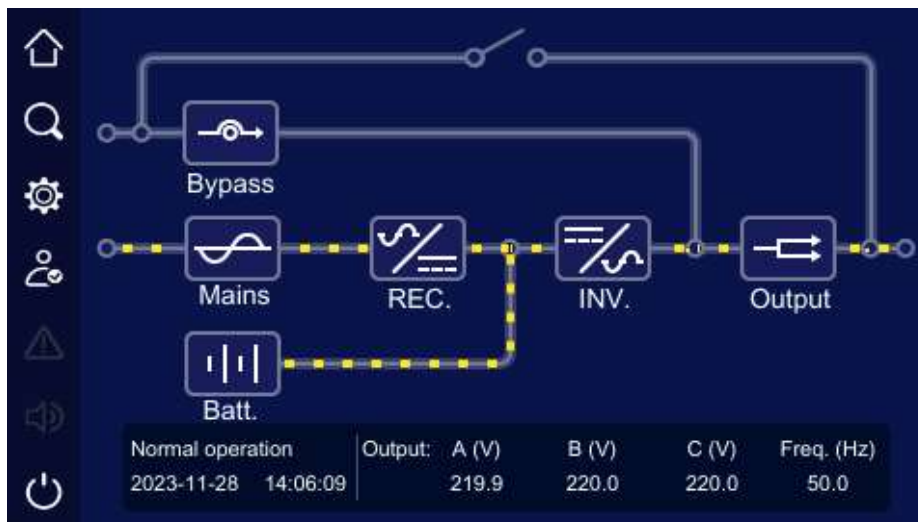

Figure 5.3 Mains inverting status

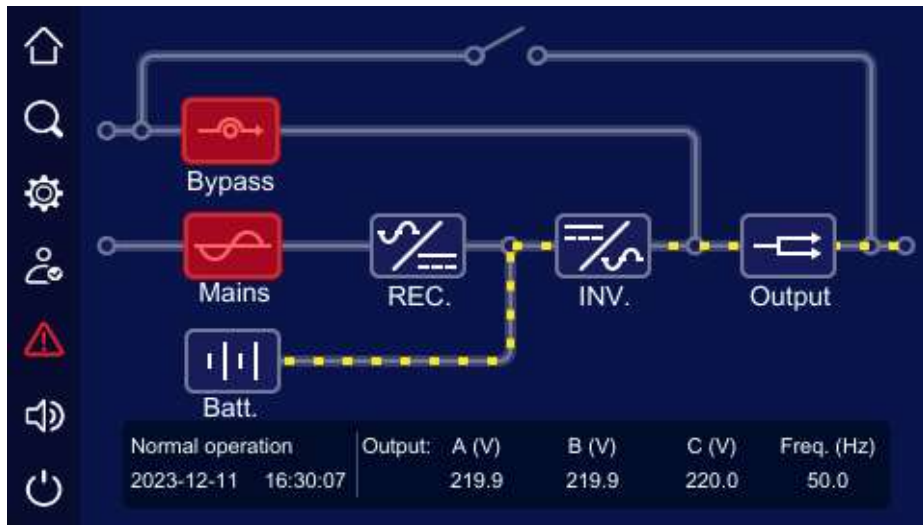

Figure 5.4 Battery inverting status

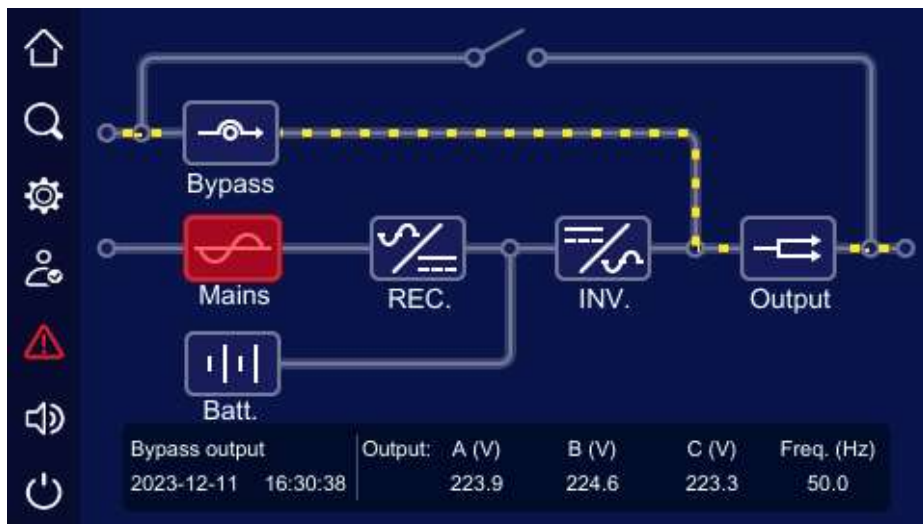

Figure 5.5 Bypass output status

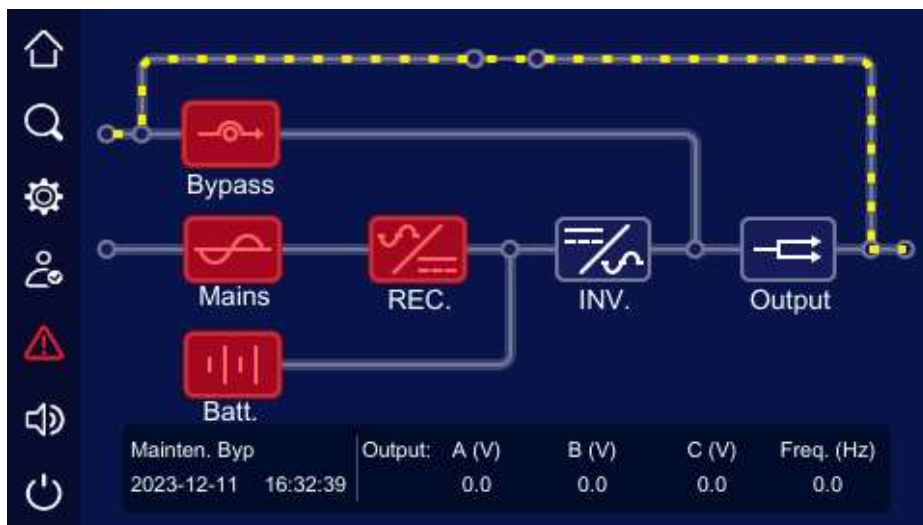

Figure 5.6 Maintenance bypass output status

5.2.2 Icon Meaning

In the main page, it shows the topological structure of system. The icon meaning is as follows:



: Main page. Tap the icon in any page, it will return to the main page.



: Information management. Tap the icon it will enter the information management page.



: Setting management. Tap the icon, it will enter the setting management page.



: Alarm. If there is any fault, tap the icon, you can check the corresponding alarm information.



: Buzzer. Tap the icon to control the buzzer.



: Login.



: ON/OFF.



: Bypass information. When bypass is abnormal, the icon will be on and show



: Mains information. When mains is abnormal, the icon will be on and show



: Battery information. When battery is abnormal, the icon will be turn on and show



: Output information. When output is abnormal, the icon will be on and show



5.2.3 Bypass Information

NOTE

11 series EW 6000-Li system input current display is not supported.

On main page, tap "" icon, it will enter the bypass information page, as shown in the picture below.

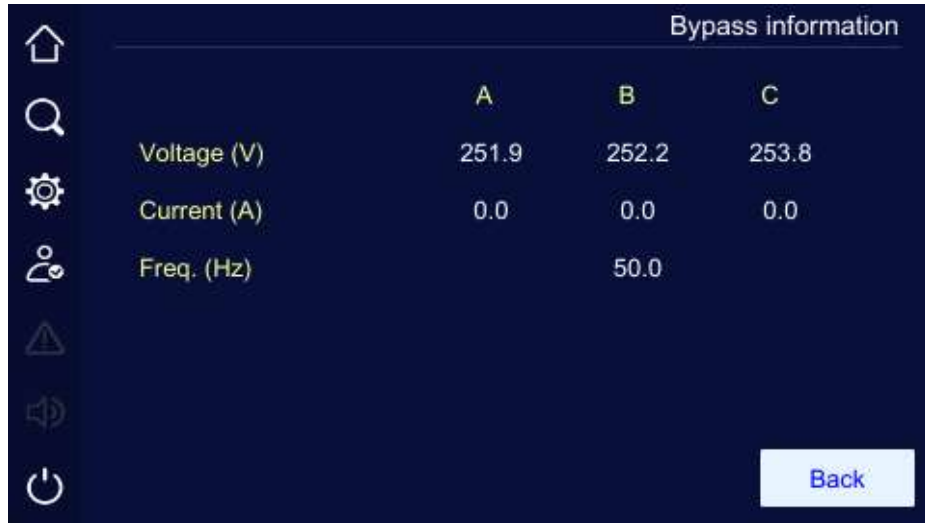

Figure 5.7: Bypass information page

5.2.4 Mains Information

In the main page, tap "" icon, it will enter the mains information page, as shown in the picture below.

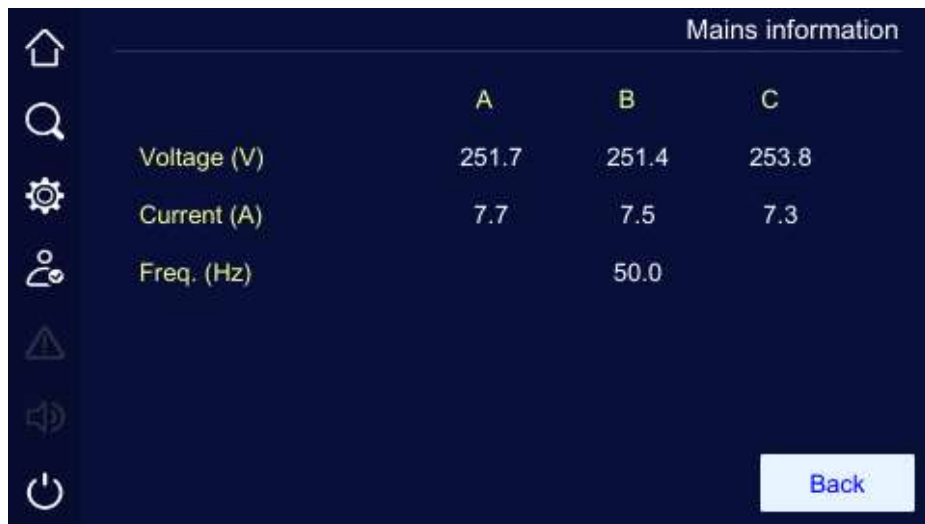



Figure 5.8: Mains information page

5.2.5 Battery Information

Battery Cabinet Info

In the main page, tap "" icon, it will enter the battery information page. The "Batt. cab. info." page shows information such as battery voltage, battery current, battery status, system SOC(%), system SOH(%), remaining time. As shown in the picture below.

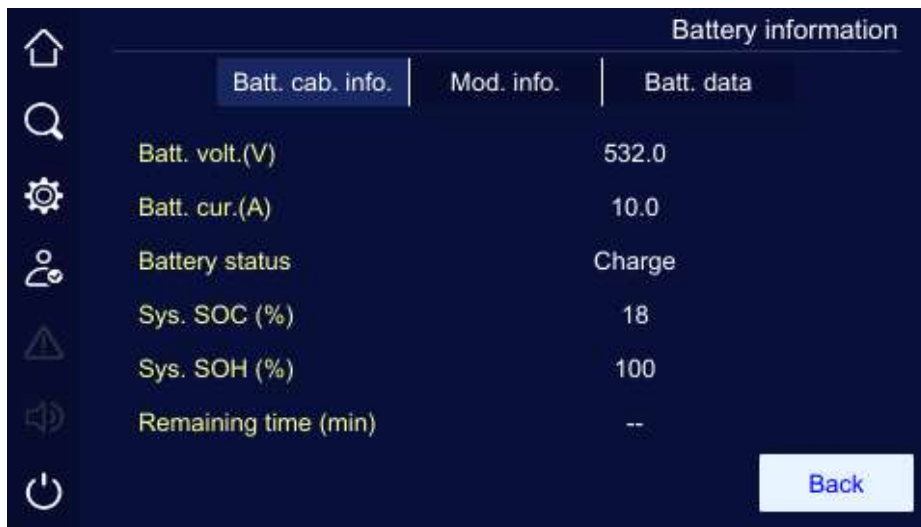

Figure 5.9: Battery cabinet info

Module info

The "Mod.info" page shows battery pack information such as PACK voltage, PACK temperature, Mod. SOC, Mod. SOH, total current, inner temperature, route1 charge/discharge voltage, route2 charge/discharge voltage, route1 charge/discharge current, route2 charge/discharge current, module On/Off status, charge/discharge status, system operation time, module status, positive insulation impedance, negative insulation impedance, max. cell voltage, min. cell voltage, max. cell temperature, min. cell temperature. As shown in the picture below.

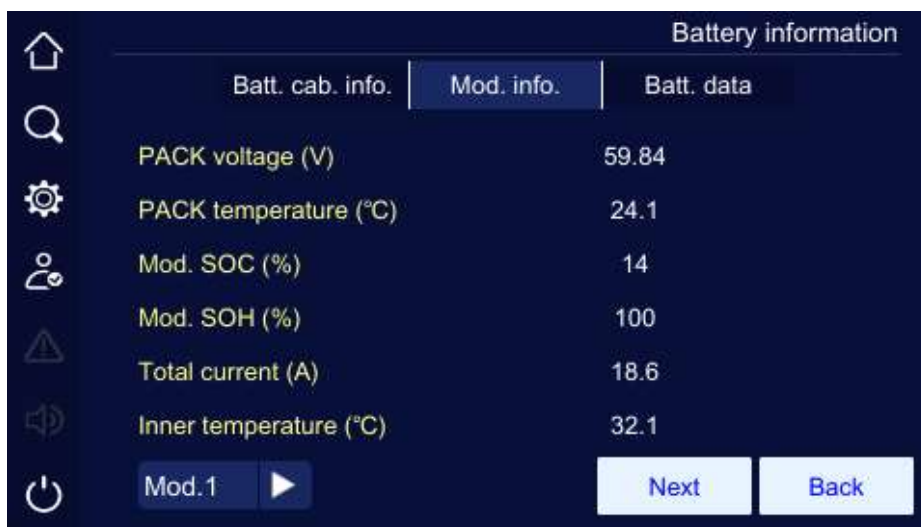

Figure 5.10 Module info

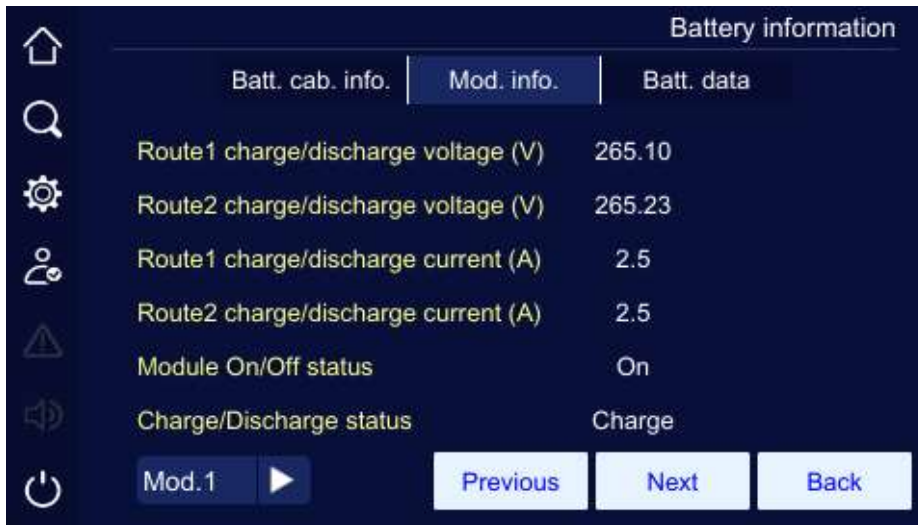

Figure 5.11 Module info

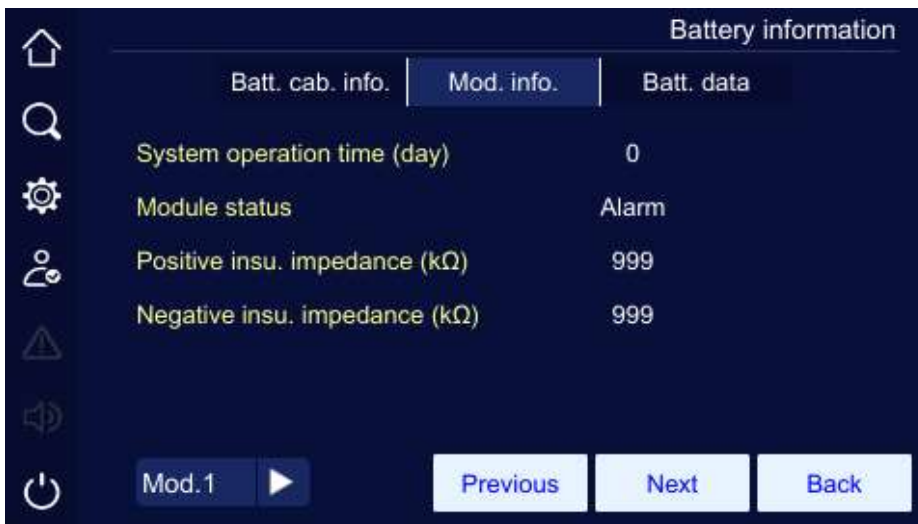

Figure 5.12 Module info

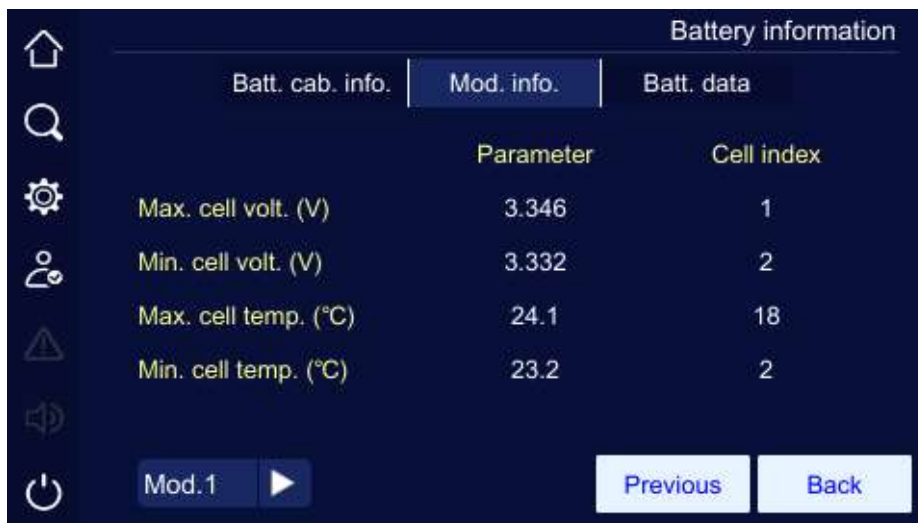

Figure 5.13 Module info

Battery data

The "Batt. data" page shows cell no., cell voltage, cell temperature. As shown in the picture below.

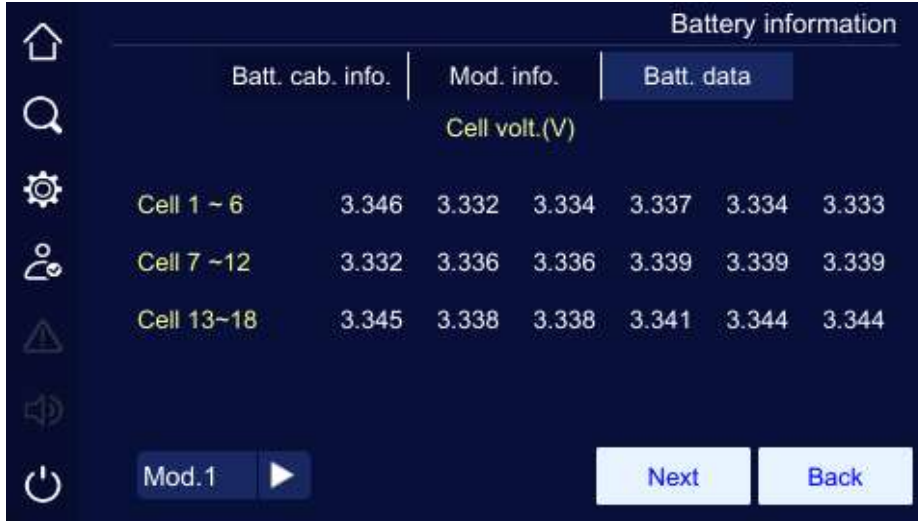

Figure 5.14 Cell voltage

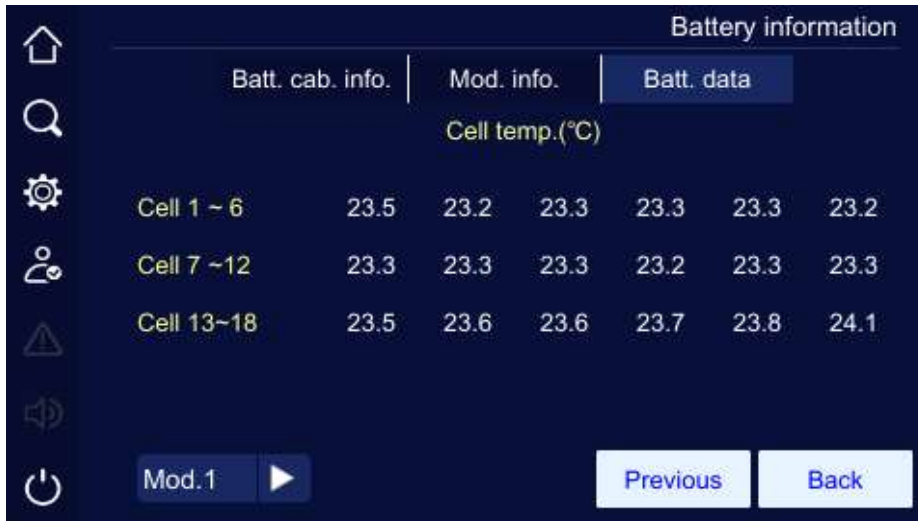

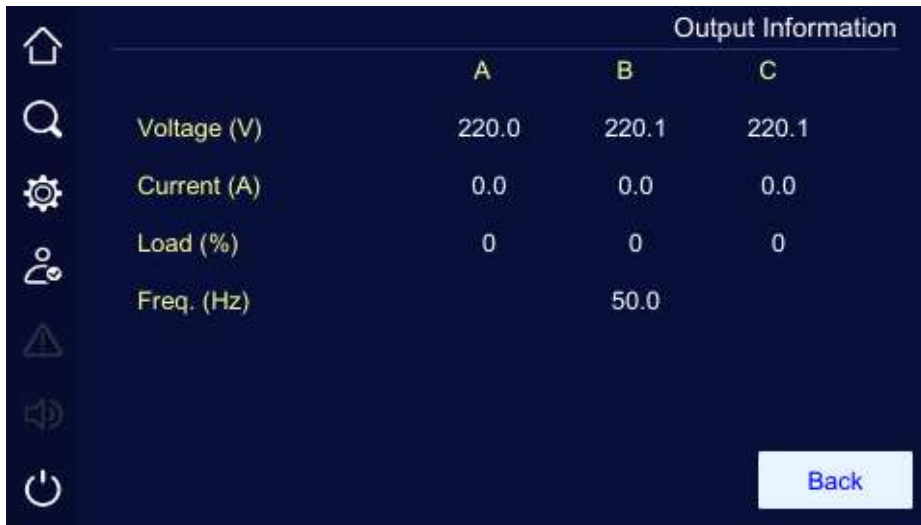

Figure 5.15 Cell temperature

5.2.6 Output Information

In the main page, tap "" icon, it will enter the output information page. The page shows information including information such as voltage, current, load, frequency.



Output Information			
	A	B	C
Voltage (V)	220.0	220.1	220.1
Current (A)	0.0	0.0	0.0
Load (%)	0	0	0
Freq. (Hz)		50.0	

Figure 5.16: Output information

5.3 Login

In the main page, tap "  " icon, it will enter the login page, as shown in the picture below.

NOTE

The password for common user is 111, the password for administrator is 222. Common user can check the parameters only, administrator can check and set the system parameters.

5.4 Information Management

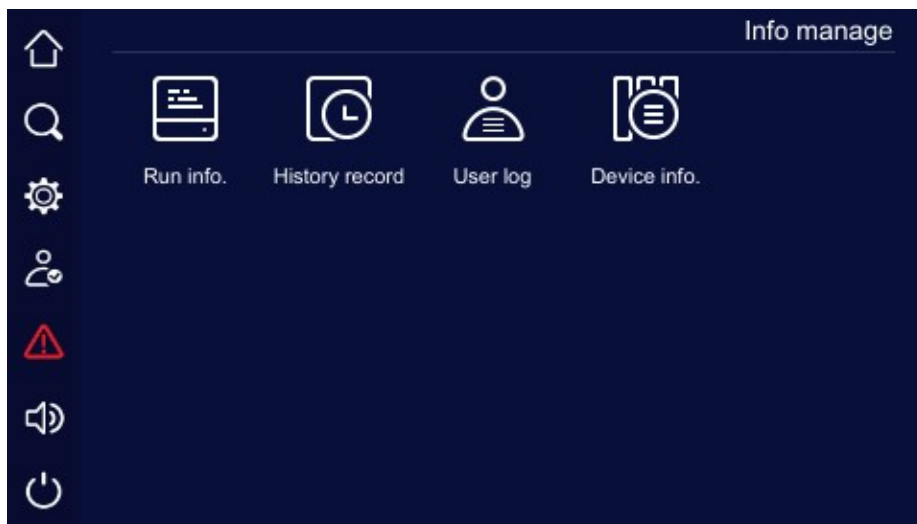

Figure 5.17: Information management page

5.4.1 Run Information



In the "info manage" page, tap "📄" icon, it will enter the run information page. The page shows information including mains status, bypass status, maintenance bypass status, battery status, rectifier status, inverter status, output status, ECO status, EPO status, fan status, system inner temperature. As shown in the picture below



Figure 5.18: Run information

5.4.2 History Record



In the "info manage" page, tap "🕒" icon, it will enter the history record page. The page shows the fault and alarm information, and they are listed on the basis of time. The first record is the latest fault. As shown in the picture below.

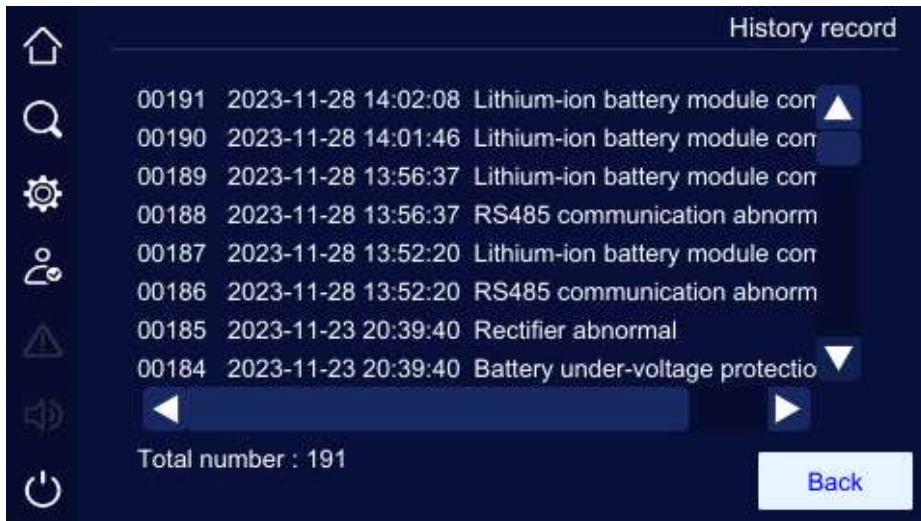

Figure 5.19: History record

5.4.3 User Log

In the "info manage" page, tap the "👤" icon, it will enter the user log page. The page shows the operation records, such as ON/OFF operation, battery charge current setting, etc. The user log is listed on the basis of time. The first record is the latest operation record. As shown in the picture below.



Figure 5.20: User log

5.4.4 Device Information

In the "info manage" page, tap the "🏠" icon, it will enter the device information page. Device information page includes product name, HMI software version, UPS version, module software version, etc. As shown in the picture below.

Figure 5.21: Device information

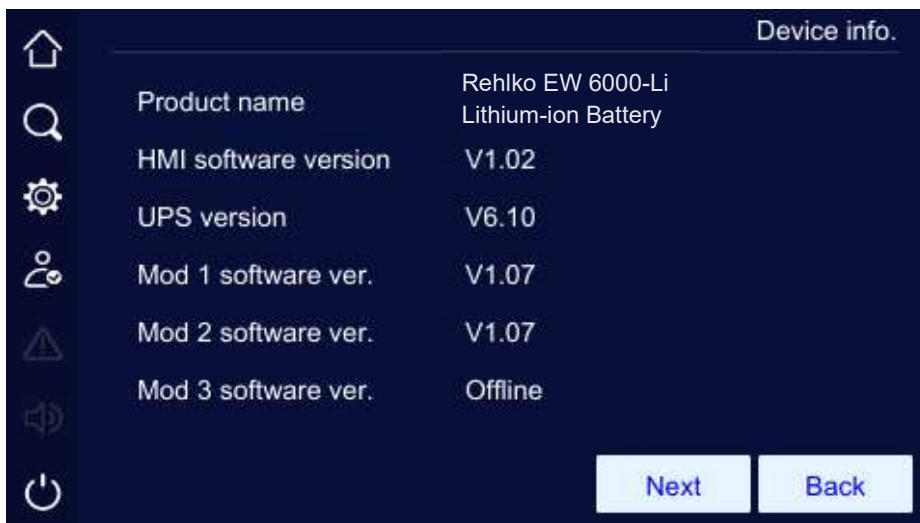





Figure 5.22: Device information

5.5 Device Management



In the main page, after login, tap "  " icon, it will enter the setting manage page. The page includes: battery manage, battery test, communication setting, HMI setting, password setting, record management and upgrade. As shown in the picture below.

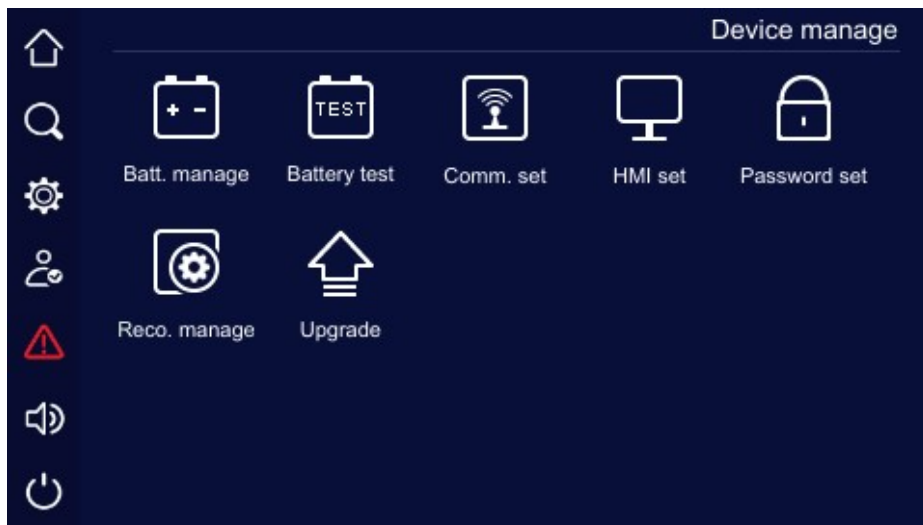



Figure 5.23: Device management page

5.5.1 Battery Manage



In the "device manage" page, tap "  " icon, it will enter the battery manage page. The page includes li-batt. module quantity, max. battery charge current, li-batt. forced charge trigger, li-batt. forced insulation detection, li-batt. SOC balance enable.

NOTE

Users can only view it. If you want to set it up, please log in with administrator privileges.

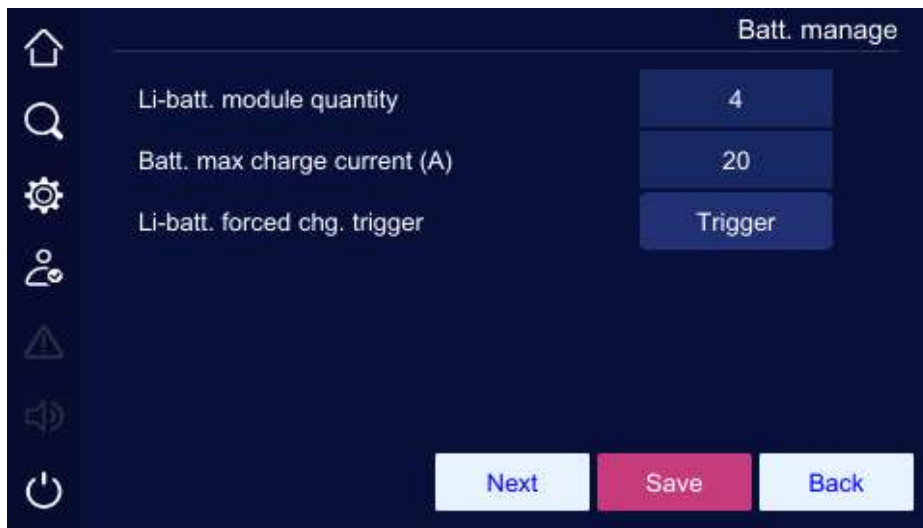

Figure 5.24: Battery manage

The maximum charging current of the cell is estimated as follows.

- 33 series EW 6000-Li system

$$I_{\text{Max.cell charge current}} = \frac{530 \times I_{\text{UPS max}} \times 92\% \times 95\%}{N_{\text{Total modules}} \times 62} \approx 7.5 \times \frac{I_{\text{UPS max}}}{N_{\text{Total modules}}}$$

- 11 series EW 6000-Li system

$$I_{\text{Max.cell charge current}} = \frac{265 \times I_{\text{UPS max}} \times 92\% \times 95\%}{N_{\text{Total modules}} \times 62} \approx 3.75 \times \frac{I_{\text{UPS max}}}{N_{\text{Total modules}}}$$

Parameter description:

$I_{\text{UPS max}}$: Maximum UPS charging current (A).

$N_{\text{Total modules}}$: Total quantity of system modules.

Example:

Take 33 series EW 6000-Li system (with 10K/15K/20K UPS) for example, the maximum charging current of the UPS unit is 10A; configure four battery modules, then the maximum charging current of the cell is set to:

$$I_{\text{Max.cell charge current}} \approx 7.5 \times \frac{10}{4} \approx 18.75(\text{A}), \text{ take } 18\text{A}$$

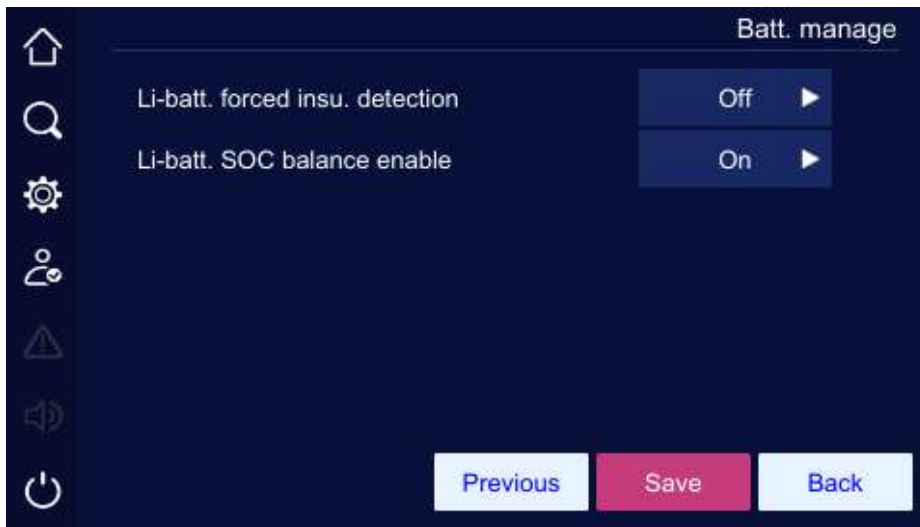



Figure 5.25: Battery manage

5.5.2 Battery Test

In the "device manage" page, tap  icon, it will enter the battery test page. The page includes standard test, deep test and the timing test, and the test also can be cancelled. As shown in the picture below.

 **NOTE**

Users can only view it.

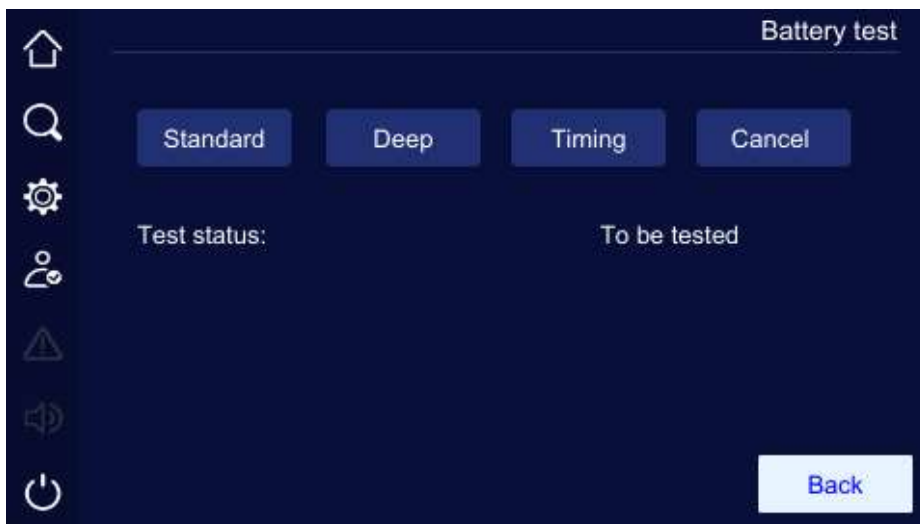
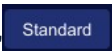



Figure 5.26: Battery test

The battery test needs to ensure that the system is powered on with normal mains and bypass power, and that the battery module is fully charged and in the sleep state.

Standard test

After tapping  icon, the system will switch to the battery inverter working state (as shown in 0), and the green LED of the battery module will flash slowly (discharged state), and after 10S, the system will restore the mains inverter working state and turn on charging.

Deep test

After tapping "  " icon, the system will switch to the battery inverter working state (as shown in 0), the LED of the battery module will flash slowly in green (discharged state), the battery inverter will work until the battery module is under-voltage protected, and the system will restore the mains inverter working state and turn on charging.

Timing test

After tapping the "  " icon and setting the battery test duration, the system will switch to the battery inverter working state (as shown in 0), the green LED of the battery module will flash slowly (discharged state), and the system will restore the mains inverter working state and turn on the charging when the set battery test duration is over.

5.5.3 Communication Setting

In the "device manage" page, tap "  " icon, it will enter the battery test page. The page shows Modbus station number and Modbus baud rate. As shown in the picture below.

NOTE

Users can only view it.

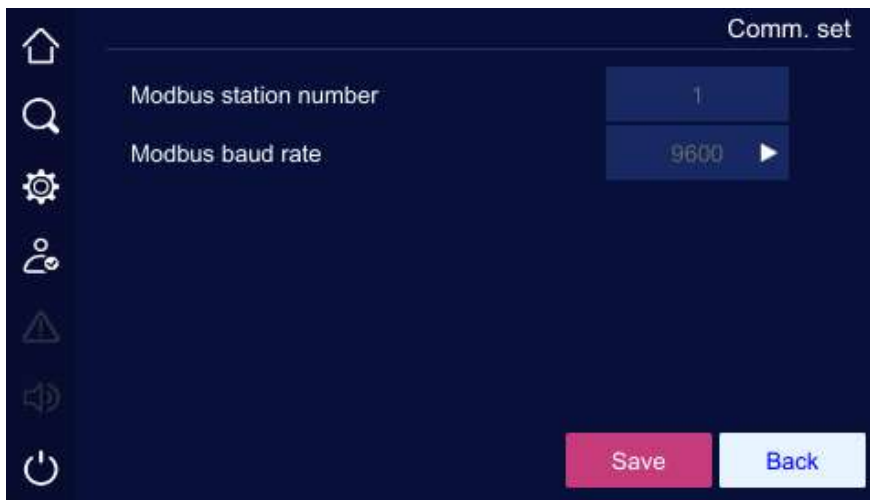

Figure 5.27: Communication setting

5.5.4 HMI Setting



In the "device manage" page, tap " " icon, it will enter the HMI setting page. In HMI setting page, user can set the date, time, language, backlight and brightness. As shown in the picture below.



Figure 5.28: HMI setting

5.5.5 Password Setting

In the "device manage" page, tap " " icon, it will enter the password setting page. In the password setting page, users can change the login password. As shown in the picture below.

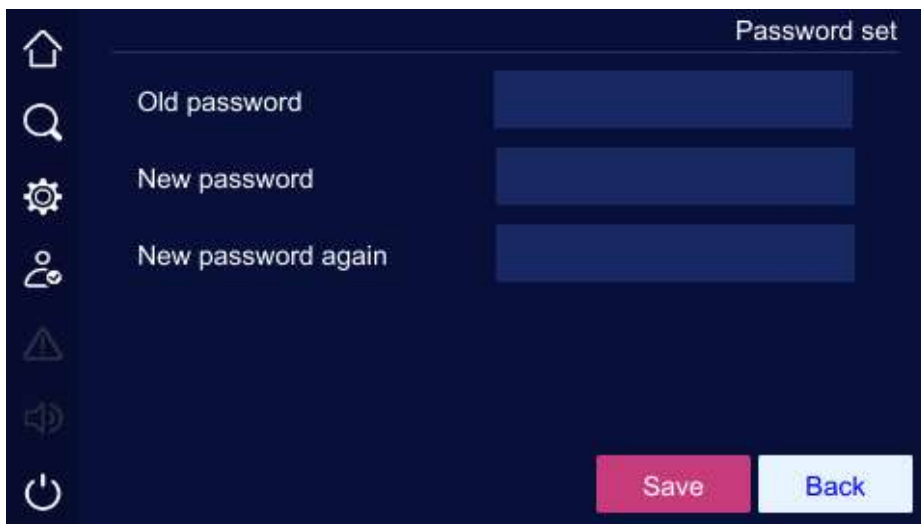





Figure 5.29: Password setting

Record Manage

In the "device manage" page, tap  icon, it will enter the record management page. Tap  button, you can export the selected items by USB flash drive, tap the  button, you can clear the selected items. As shown in the picture below.

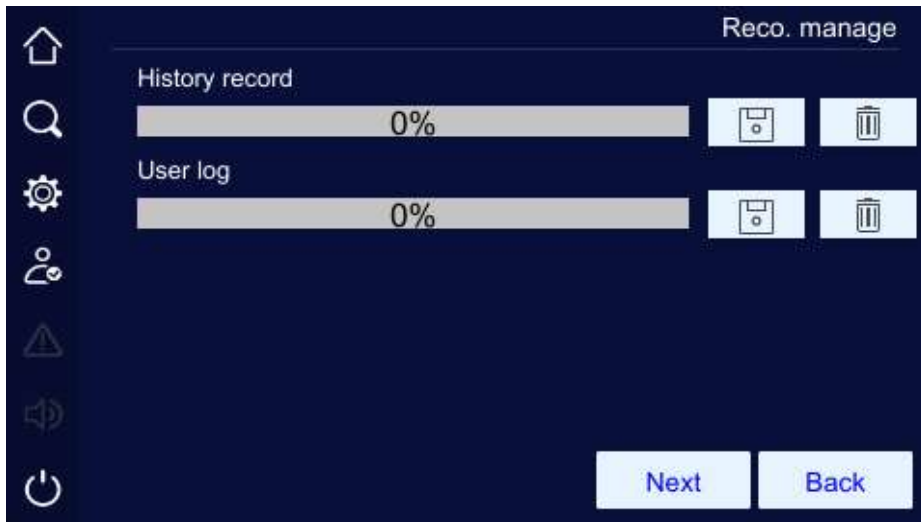

Figure 5.30: Record management

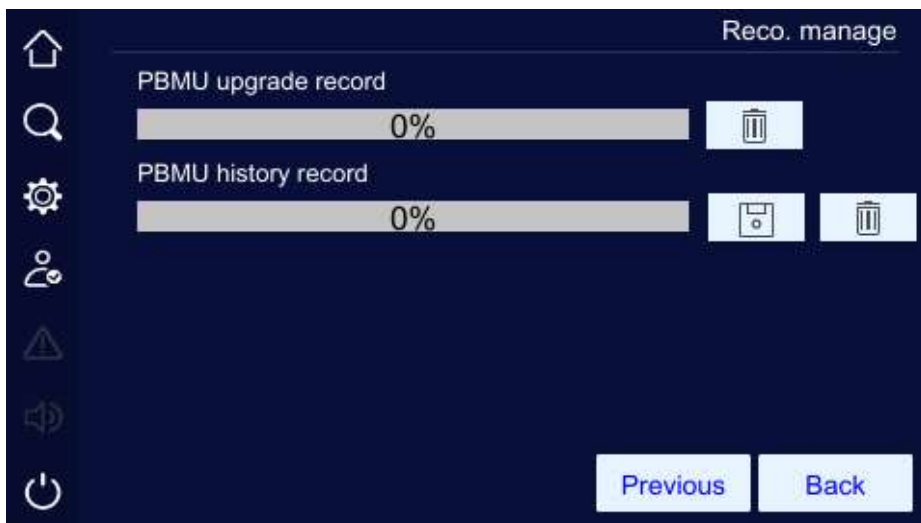

Figure 5.31: Record management

5.5.7 Upgrade

In the "device manage" page, tap  icon, it will enter the upgrade page.

NOTE

Upgrade should be carried out under the guidance of after-sales service.

During the HMI online upgrade process, if loses power, it may cause touch screen abnormal.

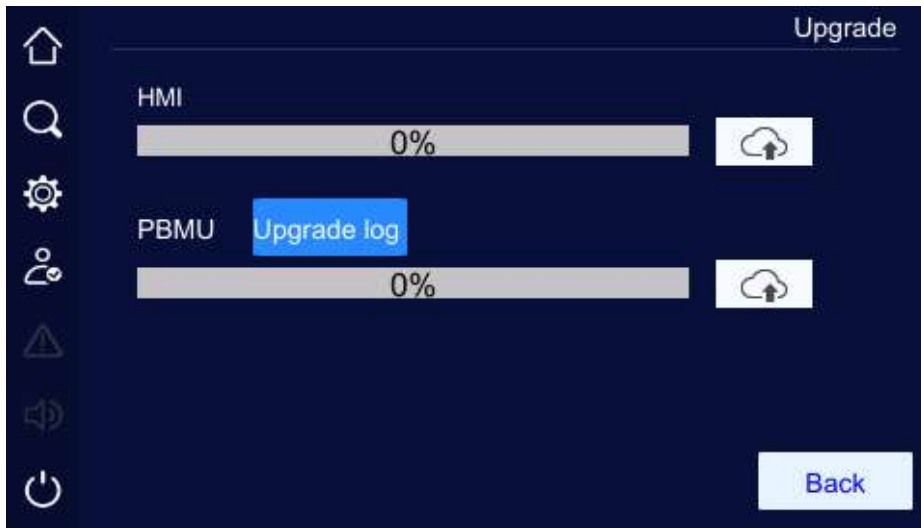



Figure 5.32: Upgrade page

5.6 Current Fault

When the system is fault, the "" icon at the left will light on. Tap it, the page will show the current fault information, as shown below.

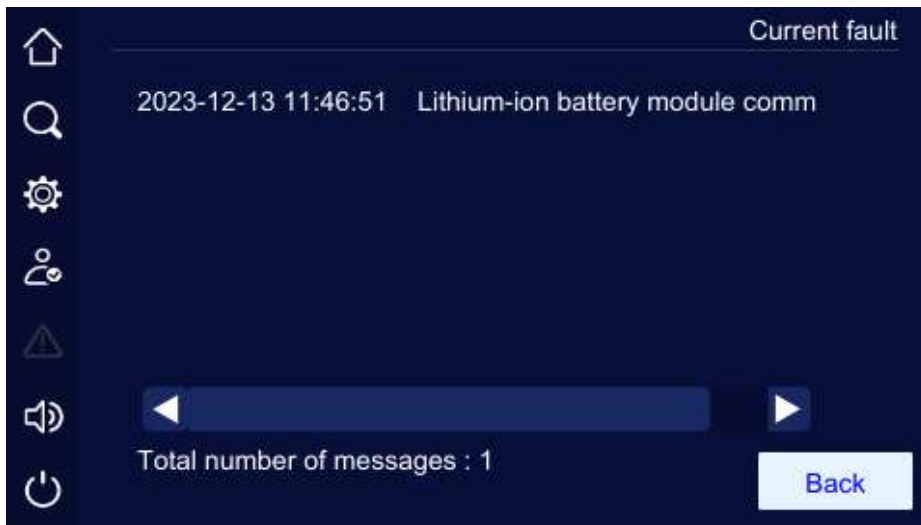



Figure 5.3.3: Current fault

5.7 Buzzer Control

When UPS unit or system fault, the buzzer icon will light on. Tap the "" icon, the buzzer can be muted or opened. After the buzzer is muted, if a new fault is generated, the buzzer will be opened automatically

5.8 ON/OFF Operation

 **NOTE**

When system ON/OFF operation, both the UPS unit and the battery module should be switched off and the battery module stops working.

5.8.1 Power on Operation



In main page, tap "Power on" icon, the system can be started or shutdown. When the system is shutdown, tap the icon, it will show "Confirm to power on?", tap the "Confirm" button to perform it. As shown below.

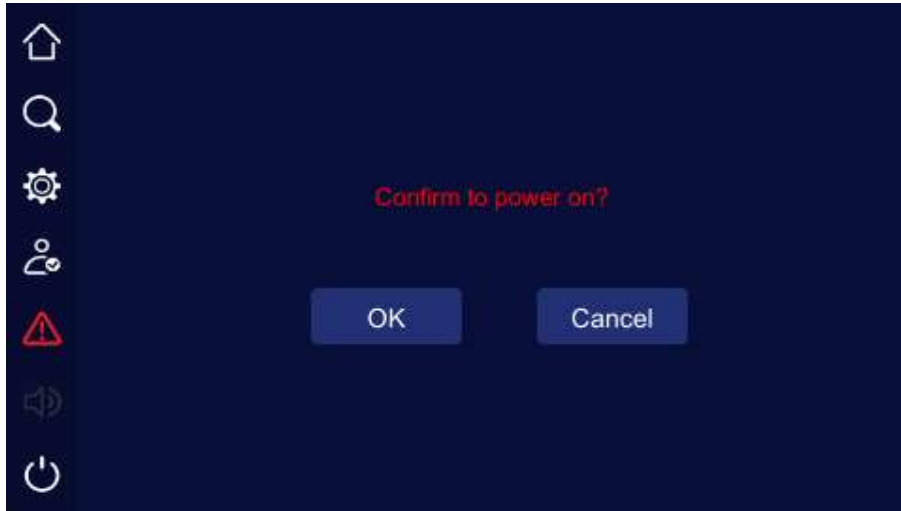

Figure 5.34: Power on operation

5.8.2 Power off Operation



In main page, tap "Power off" icon, the system can be started or shutdown. When the system is started, it will show "Confirm to power off?", tap the "Confirm" button to perform it. As shown below.

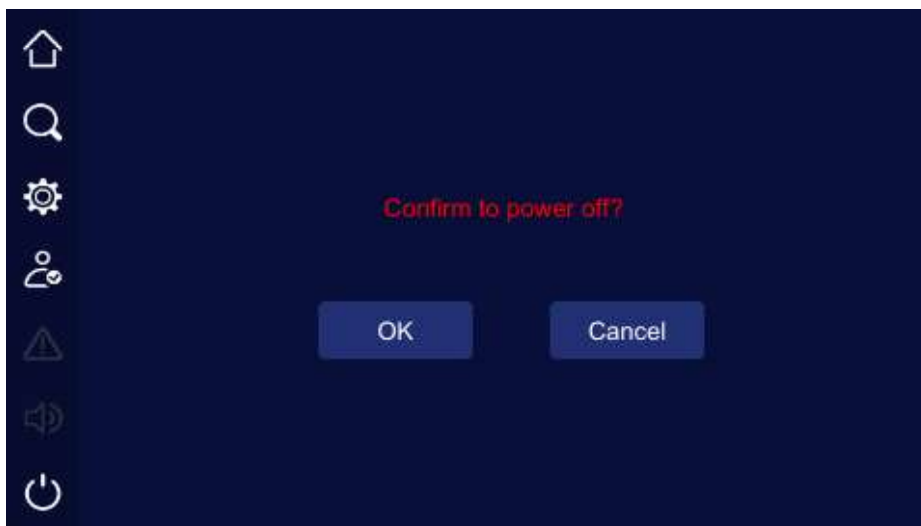



Figure 5.35: Power off operation

6. Daily Operation

6.1 User Notices

- The system is equipped with breaker, before power on the system, please close the battery breaker of power distribution module to avoid the UPS unit without output when mains abnormal. While maintaining the system, please disconnect the battery breaker of power distribution module, and turn all battery module knob to  position (module indicator lights are all off) to prevent the electric shock damage.
- Before powering on the system, please check the load of UPS unit, and confirm the load cannot exceed 90% of the rated output power of system, which is to avoid overload protection for the system.
- When the UPS unit in the system is unable to charge the battery module, please check whether the current charging voltage of the UPS unit meets the requirements. 11 series EW 6000-Li system are required to meet $265\pm 5\text{VDC}$ (parallel connection), and 33 series EW 6000-Li systems are required to meet $\pm 265\pm 5\text{VDC}$ (series connection).

6.2 Startup Operation

Step 1: Switch the ON/OFF knob on all battery modules to  status to start the modules. All green lights are on

Step 2: Close the main power switch, bypass switch, and battery switch on and outside the system power distribution module.

NOTE

The 11 series EW 6000-Li system only have mains breaker.

Step 3: Wait for about 1 minute for the touch screen to start up completely and tap "" button on the touch screen.

Step 4: After about 10 seconds, close the output breaker after the system working normally, so that the user can open the computer and other load devices.

Step 5: Close the front door of the system.



Start load according to "high power device→small power device", which is to avoid overload protection when starting high power device.

6.3 Shutdown Operation

Step 1: Close load and keep the system running without load for about 10min to exhaust heat.

Step 2: Tap "" button on the touch screen.

Step 3: Disconnect the battery, bypass, mains, and output switches on the system distribution module.

Step 4: Turn the switch on all battery modules to  position, all indicators are off.

6.4 Lithium-ion Battery Module Cold Start

NOTE

Cold start of the battery module needs to be operated using the UPS unit operation panel, the location of the UPS operation panel see 0Structure Layout.

UPS unit operation panel of 11 series EW 6000-Li system as shown in ① of 0.

UPS unit operation panel of 33 series EW 6000-Li system as shown in ② of 0.

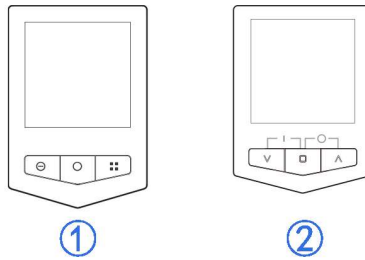



Figure 6.1: UPS unit operation panel

Step 1: Close the battery breaker on the distribution module.

Step 2: Switch the ON/OFF knob on all battery modules to  status to start the modules. The three indicators flicker at the same time, it starts to initialize and self-test. About 10s later, the green indicator flickers once every 1s, the module turns to discharge mode, the touch screen light on.

Step 3: Press the "□" and ">" buttons on the operation panel of the UPS unit simultaneously for 5 seconds and the UPS unit start.

NOTE

11 series EW 6000-Li system requires pressing the "ⓘ" button on the UPS unit operation panel lightly for 5s.

6.5 Maintenance Bypass Operation

6.5.1 Maintenance Bypass Power Mode

Step 1: Remove the maintenance bypass switch protection plate first, the maintenance bypass status detection switch automatically will pops up, the UPS unit will then force the inverter off to switch to bypass power.

Step 2: Close the maintenance bypass switch on the distribution module.

Step 3: Switch the ON/OFF knob on all battery modules to  status (module indicator light is completely off) . In this state, the mains input, bypass input and output interfaces of the distribution module are with a forced current.

At this time, the load is transferred to the maintenance bypass power supply, the system input and output power are disconnected, and the UPS unit can be maintained.

6.5.2 Maintenance Bypass Power Restoration to Inverter Power

Step 1: Restore the wiring between the UPS unit and the distribution module (maintenance bypass status detection signal wire is included).

Step 2: Close the AC input switch, bypass switch, and AC output switch on the distribution module in sequence.

Step 3: After the system working power is normal and there is a bypass output, confirm that the system bypass output and the maintenance bypass output have the same source and the same phase, then close the output switch, and finally disconnect the maintenance bypass breaker.

Step 4: Lock the maintenance bypass switch protection plate.

Step 5: Tap the  button on the system touch screen to let the inverter power the system.

7. Troubleshooting

7.1 Safety Precautions

To ensure human safety and device safety, observe the following precautions.

- Please keep in mind that there is dangerous voltage inside the system even if it does not operate. Before maintenance, use a multi-meter to check the voltage and make sure that the system is completely shut down and stays in safe status.
- Do not wear any conductive metal objects during operating, such as ring, watch.
- Observe safety regulations strictly. If any doubt, please consult professionals who is familiar with the system.

7.2 Preventive Maintenance

To improve the reliability and efficiency of system, perform the following maintenance tasks regularly.

- Keep the operating environment clean to avoid dust or chemical pollution to the system.
- Check the wiring terminals on input, output cables to see if the contact is in good status.
- Check the fans work status regularly, avoid sundries blocking the air vents. If a fan is damaged, maintain or replace it in time.
- Check the SOH of battery modules and the work status of system regularly to ensure that any fault can be found in time.

7.3 Maintenance of Battery Module

7.3.1 Daily Maintenance of Battery Module

- Charge requirement
 - When first use, please start the UPS unit and charge the battery module. During charging, the system still can be used, but if power outage occurs at the same time, the battery module discharge time may less than the standard vale this time.
 - If the battery module not used for a long time, please charge it every 3 months.
- Clean requirement
 - Clean the shells of battery module by cloth. Oil and organic solvents, such as petrol and diluents are prohibited.
- Environment requirement
 - Keep the battery modules far away from fire sources and devices that easily generate sparks to avoid explosion.
- Usage requirements
 - If the system needs to stop using, please switch off the battery breakers on the system and screw the ON/OFF knob on the battery module to  status to avoid long discharge, and even cause excessive power loss in the battery module, which cannot be recovered.
- Storage requirements
 - Battery modules are dangerous, which should be produced and warehoused in accordance with the requirements for dangerous goods production and storage warehouses, please confirm the report with the fire emergency in advance. Battery modules should be stored at 25%-50% charge of rated capacity.

7.3.2 Announcements for Battery Module Replacement

- Do not put the battery module into fire, which is to avoid explosion.
- Do not open or disassemble the battery module, especially for the inner cells, which is to avoid electric shock or burn dangerous.
- The recycle for the battery module should be done according to corresponding laws and regulations.
- Dangerous voltage may exist in the output end of the lithium-ion battery module, before contacting, please check if there is dangerous voltage to avoid endanger human safety.

- Keep the ON/OFF knob of replaced module at  status, if the replaced battery module needs to be transported, it is suggested to pack the module the original package material or contact the local agency or distributor of Rehiko Company.

7.4 Troubleshooting

As shown in the picture below, it only includes some common fault diagnosis. If any doubt, contact the local office or distributor for details.

7.4.1 Common Fault

Table 7.1: Troubleshooting

Fault phenomenon	Possible reason
The mains normal, after starting the UPS unit, it outputs normally, but it works in the battery inverter mode and the buzzer beeps intermittently.	Check if the contactors and wiring terminals in the input circuit are in good condition. Check if the displayed input voltage amplitude or frequency of mains on the screen is beyond the allowable range of UPS unit;
After installing UPS unit, connecting with power will fuse the fuse or cause tripping operation.	UPS unit output is short circuit.
After starting, the screen display and output are normal. But once connecting with load, it will stop outputting immediately.	UPS is overload seriously or the output circuit is short-circuited. Please reduce load to proper capacity or find the short-circuit reason. The common reason is that the output changeover socket short-circuits, or the input short-circuit after UPS unit damage. The load is not started according to "high power device → small power device". Restart the UPS unit, and after the UPS unit works steadily, start high power load first, and then start small power ones successively.
Buzzer long beeps, fault indicator lights on, UPS unit works in bypass mode and inverter failure.	The output is overload. The load is too heavy and beyond the rated power of the UPS unit. Please reduce load or select a UPS unit with larger power capacity. If it is temporary bypass caused by impact of load start and recovers automatically, it still is normal. UPS unit over-temperature protection. Check if the air inlet and air outlet of UPS is blocked or the working temperature of UPS unit is beyond the allowable range.
Usually, UPS unit works normally. When power failure, it doesn't transfer to battery mode, or it transfers to battery mode and battery under-voltage protection soon.	Battery aging, the battery capacity loss. Please replace battery. Battery charger fault. At ordinary time, the battery cannot be charged. Battery wire doesn't connect well, or the terminals contact is bad. Battery breaker not closed.
When the load is PC, everything works normally. When power failure, UPS unit works normally, but the computer system halted.	The grounding connection is not so good. The floating voltage between the neutral wire and the grounding wire is too high.

7.4.2 UPS Unit Operation Screen and Buzzer Fault

Table 7.2: UPS unit operation screen and buzzer fault for 11 series EW 6000-Li system

Fault	Buzzer status	Meaning	
Fault information page (viewed by pressing  to turn the page)	EPO	Long beep	UPS unit has emergency protection (if equipped with EPO function), Bypass output and inverting output are all closed.
	BUS	Long beep	UPS unit internal bus voltage faults and the inverter output is off.
	TMP	Long beep	The UPS unit is over-temperature protected, and the inverter output is turned off. Please check whether the fan of the UPS unit is working properly, and whether the UPS inlet and outlet air paths are clear, etc.
	FAN	Urgent beep (alarm once about every 0.5s)	Fan fault warning prompt, please check the fan for damage or blocking.
	FAN OUT	Long beep	Fan fault protection, UPS unit inverter output off.
		Long beep	UPS unit output fault, please check whether the UPS unit output is short-circuited or overloaded.
BAT	Long beep	Battery of UPS unit battery fault, battery has low voltage protection or high voltage protection.	
Load energy bar "25% to 100%, overload" all flashes.	Long beep	UPS unit output overload warning, device output is about to shut down, please reduce the UPS unit load.	

Fault	Buzzer status	Meaning
"Overload" symbol on load energy bar	Long beep	UPS unit output overload protection, device output has been turned off.
Load power bar "Short circuit" light up.	Slow beep (alarm once about every 2.0s)	UPS unit output short-circuit; device output has been turned off.
Battery power bar "25% to 100%, overvoltage" all flashes.	Urgent beep (alarm once about every 0.5s)	The UPS unit battery energy is about to run out, please pay attention to protect the load and save the computer data.
Battery power bar "Under voltage" symbol flashes.	Urgent beep (alarm once about every 0.5s)	The UPS unit battery energy is about to run out, please pay attention to protect the load and save the computer data.

 **NOTE**

The above table is only for users to understand the abnormal alarm information of the UPS unit's working process, when it involves the internal troubleshooting of the device, please contact the professional personnel.

Table 7.3: UPS unit operation screen and buzzer fault for 33 series EW 6000-Li system

No.	Fault	Buzzer status	Meaning
1	EPO	Long beep	UPS unit has emergency protection (if equipped with EPO function), Bypass output and inverting output are all closed.
2	Mode fault	Long beep	UPS unit mode settings and the actual wiring do not match the fault, please check the main power or bypass wiring, and make the actual system is consistent with the set mode system.
3	Maintain bypass fault	Long beep	UPS unit maintenance bypass protection, inverted output closed, please checks back board maintenance bypass detection port is shorted.
4	Output fault	Long beep	UPS output is faulty; detect the UPS output is short or overload.
5	Mode mismatch	Long beep	UPS unit of the input and output mode in the parallel does not match the actual system.
6	Voltage mismatch	Long beep	UPS unit of the output voltage in the parallel does not match the actual system.
7	Frequency mismatch	Long beep	UPS unit of the frequency in the parallel does not match the actual system.
8	Bypass mismatch	Long beep	UPS unit of the bypass voltage or frequency in the parallel does not match the actual system.
9	Mode mismatch	Long beep	UPS unit parallel mode setting in the parallel system does not match the actual system.
10	Power mismatch	Long beep	UPS unit of the output power setting in the parallel does not match the actual system.
11	Battery number mismatch	Long beep	UPS unit of the battery number setting in the parallel does not match the actual system.
12	Parallel mismatch	Long beep	UPS unit of parameters setting in the parallel does not match the actual system.
13	Short mismatch	Long beep	UPS unit of short turn to bypass setting in the parallel does not match the actual system.
14	Two-ended fault	Long beep	Fall-off fault at both ends of the parallel wire.
15	Single-ended fault	Slow beep	Fall-off fault at one end of the parallel wire.
16	Auxiliary power supply fault	Long beep	UPS unit internal working power fault, if it cannot be automatically recovered, please report repair promptly.
17	Fan fault	Urgent beep (alarm once about every 0.2s)	Fan fault warning prompt, please check the fan for damage or blocking.
18	CAN fault	Slow beep (alarm once about every 2.0s)	The CAN communication of parallel system abnormal, please check if the parallel wire is damaged or there is only one UPS unit in parallel system works.
19	SCI fault	Long beep	UPS internal communication abnormal, if the continuous alarm cannot be restored, please report repair promptly.
20	There is no redundancy in the parallel UPS unit	Slow beep (alarm once about every 2.0s)	The total output load of the UPS unit parallel system exceeds the full load of the single machine, check that the output load exceeds the requirements for redundant backups.

No.	Fault	Buzzer status	Meaning
21	Main power abnormal	Long beep	The mains power input phase sequence is abnormal, please check the main power input wiring.
		Three consecutive alarms at 10s intervals	The main power input occurs lack N fault, power down fault, overvoltage protection, under voltage protection, over-frequency fault, under-frequency fault, please check whether the main power input status is normal.
22	Bypass abnormal	Slow beep (alarm once about every 2.0s)	At mains status, the bypass voltage abnormal, frequency abnormal, phase sequence abnormal, or mode setting mismatches the wiring. Please check if the bypass breaker is closed, if the bypass phase sequence is normal, if the wiring way of bypass matches the system mode setting.
23	Battery abnormal	Slow beep (alarm once about every 2.0s)	Battery has over-voltage protection, charging fuse fault, over-pressure alarm fault, please check the battery status is normal.
		Urgent beep (alarm once about every 0.2s)	Battery wiring fault, charging short, under-voltage protection, under-voltage warning problem, please check the battery wiring and the current state is normal.
		No buzzer warning	The battery charging temperature is too high.
24	Rectifier abnormal	Long beep	UPS unit rectifier fault.
25	Inverter abnormal	Long beep	UPS unit inverter fault.

 **NOTE**

The buzzer alarm in the table above describes the phenomenon of UPS unit boot state and no beep ban when the buzzer is not set, the shutdown state or some abnormal phenomena when setting the buzzer ban will prompt the information in the LCD of UPS unit, but the buzzer alarm will not be issued.

7.4.3 System or Lithium-ion Module Faults

Table 7.4: System or lithium-ion module faults

System or lithium-ion module faults	Instructions
RS485 communication abnormal	Communication between the touch screen and the UPS unit is abnormal. Please check whether the communication wiring between the touch screen and the UPS unit is normal.
Battery module quantity abnormal	The number of battery modules set by the touch screen does not match the actual number of battery modules. Please check whether the number of actual battery modules is the same as the number of battery modules set by the touch screen. Communication between the touch screen and the battery module is abnormal, check whether the communication wiring between the touch screen and the battery module is normal.
ID address conflict	Battery module address signal recognition error. Please check if the system address board wiring is normal and if the running light is on.
DC/DC module fault protection	Battery module DC/DC amplifier board abnormal. Please check the battery module amplifier board for damage.
Battery module output port reversed or short circuit protection	Battery module DC interface polarity reversed or shorted. Check whether the DC wiring polarity is correct.
DCDC temperature status abnormal	Battery module internal heat sink temperature is abnormal. Please check whether the module air outlet is blocked, the ambient temperature is beyond the requirements, if the application is normal, please check whether the battery module amplifier board is damaged.
Cell insulation status abnormal	Battery pack insulation resistance of the battery module is low. Please check whether the amplifier board or cell inside the battery module is abnormal.
Battery module fan fault alarm	Battery module heat dissipation fan works abnormal. Check whether the battery module fan is blocked or damaged.
Parallel CAN status abnormal	CAN communication between battery modules is abnormal. Check whether the communication wiring at the rear of the module is abnormal.
Battery module load status abnormal	Battery module output overload or overcurrent. Please check whether the output load of the battery module exceeds the rated power.

7.5 Emergency Response to System Faults

- Emergency response to system faults
 - When the system fails, you should first view the fault prompts through the device touch screen or use the UPS unit's operating panel to view the fault type, to determine whether the type of fault for the normal SOC low or overload protection. If the type of fault is not normal, the battery module should be turned off through the touch screen, if necessary, you can cut off the device's battery breaker to ensure that the device is not further damage and notify the engineers and technicians for maintenance.
- Emergency response to single lithium-ion battery module fault
 - When a power module fails, it will be automatically isolated from the system and will generally not affect the normal operation of the system, but it will reduce the redundancy of the module, at this time, the faulty module should be turned off and unplugged and then notify the engineers and technicians to carry out repairs.

8. Package, Transportation and Storage

8.1 Package

During packing, please pay attention to the place direction requirements. At the side of the package, there is afraid of wet, handle with care, upward, stack layer limit, etc. alarm marks. And also, the device model is pasted on the package. At front of the package, the LOGO of our company and device name is printed.

8.2 Transportation

It should be suitable for transportation by car, train, ship and airplane. During transporting, pay attention to the alarm marks and avoid severe impact on the device. Place the device according to the marked direction, which is to avoid damage the component. Any inflammable, explosive, corrosive object is not allowed to be shipped with the device. Battery modules are shipped in stacks; the capacity of transported lithium-ion battery module should be within the range of 25-50%.

8.3 Storage

While storing, place the device according to the marked direction. The package box should be far away from ground for 200mm, and keep at least 500mm from wall, heat source, cold source, window or air inlet.

Short-term storage requirements

Product storage environment temperature of $-25\text{ }^{\circ}\text{C} \sim +55\text{ }^{\circ}\text{C}$ (recommended optimal temperature $0 \sim +35\text{ }^{\circ}\text{C}$, if the storage temperature for a long time below $-10\text{ }^{\circ}\text{C}$ or higher than $45\text{ }^{\circ}\text{C}$, in order not to affect the service life of battery modules, battery modules need to be placed individually), relative humidity of $5\% \sim 95\%$ RH clean, dry, ventilated indoor, warehouses should be avoided and corrosive substances, should be kept away from sources of ignition and heat, do not allow the presence of various harmful gases, flammable, explosive substances and corrosive chemicals, and should be free of strong mechanical vibration, shock and strong magnetic field effect. There are a variety of harmful gases, flammable, explosive substances and corrosive chemicals, and there should be no strong mechanical vibration, impact and strong magnetic field.

Long-term storage requirements

Product storage ambient temperature of $-25\text{ }^{\circ}\text{C} \sim +55\text{ }^{\circ}\text{C}$, in the conditions specified in this article, the storage period, if not otherwise specified, shall generally be six months. More than six months should be re-examined for delivery.

Technical Specifications

Index		Model	EW 6000-Li
Battery module	Fire function		With module-level fire protection
	Charge state to discharge state transition time		Meet UPS unit output dynamic index requirements
	Cell insulation detection		Yes
	Protection function		Over-temperature, over-current, short-circuit, battery over-voltage, battery under-voltage, low SOC, etc.
	Electrical isolation		Yes
	Installation		Hot-swappable
Other	Power distribution modules		TN-S, TN-C, TN-C-S
	Communication method		RS485, SNMP (optional)
	Display method		4.3 inch touch screen + UPS unit LCD display
	Working temperature (°C)		-5°C~+40°C (below 0°C battery module does not charge)
	Storage temperature (°C)		-25°C~+55°C (storage temperature is lower than -10°C or higher than 45°C for a long time, in order not to affect the service life of battery module, battery module needs to be placed separately)
	Humidity		5-95% (no condensation)
	Altitude (m)		<2000m; if more than 2000m, derate according to IEC 62040-3.
	Noise (dB)		<65
	Protection class		IP20
	Cabinet weight (with power distribution module, without UPS and battery module) (kg)		All-in-one cabinet for 40AH/50AH lithium-ion module: Single cabinet: 127kg±5kg Single cabinet with 20K power distribution module: 138kg±5kg Single cabinet with 40K power distribution module: 144kg±5kg All-in-one cabinet for 100AH lithium-ion module: Single cabinet: 123kg±5kg Single cabinet with 20K power distribution module: 134kg±5kg
	System dimensions (W×D×H) (mm)		600×1000×1110 (with wheels) 600×1000×1000 (without wheels)
Maximum battery module quantity		8 (with 40AH/50AH battery module)/4 (with 100AH battery module)	

- Specifications are subject to change without prior notice.

Acronyms and Abbreviations

A

AC Alternating Current

D

DC Direct Current

DSP Digital Signal Processor

E

EPO Emergency Power Off

M

MPPT Maximum Power Point Tracking

P

PV Photovoltaic

R

RS232 Recommend Standard 232

RS485 Recommend Standard 485

U

USB Universal Serial Bus