

Kohler PW 8000DPA ST

(10–20 kVA/kW)

Parallelable up to 400 kVA/kW

User Manual



Table of contents

| | |
|--|----------|
| 1: Safety | 1 |
| 1.1 Description of symbols used in this manual | 1 |
| 1.2 User precautions | 1 |
| 2: General Description | 2 |
| 2.1 General introduction | 2 |
| 2.1.1 Reliability and quality standards | 2 |
| 2.1.2 Advanced design features | 2 |
| 2.1.3 Model range | 3 |
| 2.2 Functional description of operation | 4 |
| 2.2.1 UPS Power module internal operation | 4 |
| 2.2.2 UPS Power module operational states | 5 |
| 2.2.3 UPS system operation | 6 |
| 2.2.4 Parallel system operation | 7 |
| 2.3 Module component identification | 9 |
| 2.4 UPS Interface boards | 14 |
| 2.4.1 Customer Interface Board | 14 |
| 2.4.2 Parallel Interface Board | 14 |
| 2.5 Module control panel | 16 |
| 2.5.1 Power Management Display (PMD) | 16 |
| 2.5.2 Mimic LED indicators | 16 |
| 2.5.3 Operator keys | 17 |
| 2.6 Description of the LCD display | 18 |
| 2.6.1 Status screens | 18 |
| 2.6.2 Main menu screen | 18 |
| 2.6.3 Event log menu screen | 19 |
| 2.6.4 Measurements menu screen | 20 |
| 2.6.5 Commands menu screen | 21 |
| 2.6.6 UPS Data menu screen | 21 |
| 2.6.7 Set-up User menu screen | 22 |
| 2.6.8 Set-Up Service menu screen | 22 |
| 2.7 Optional system control panel | 23 |
| 2.7.1 Display header bar | 24 |
| 2.7.2 Mimic diagram – system level | 25 |
| 2.7.3 Module selection screen | 26 |
| 2.7.4 Home screen | 28 |
| 2.8 Warranty | 30 |
| 2.9 Extended Warranty | 30 |
| 2.10 Additional Service/Maintenance Support | 30 |

| | |
|--|-----------|
| 3: Installation | 31 |
| 3.1 Introduction | 31 |
| 3.2 Taking receipt of the UPS | 31 |
| 3.2.1 Reporting transpiration damage | 31 |
| 3.2.2 Local site transportation | 32 |
| 3.2.3 Storage | 32 |
| 3.2.4 Unpacking | 32 |
| 3.2.5 Batteries | 33 |
| 3.3 Positioning | 33 |
| 3.3.1 Planning the installation | 33 |
| 3.3.2 Clearances | 33 |
| 3.4 UPS Power Cabling (preparation and planning) | 36 |
| 3.4.1 General requirements | 36 |
| 3.4.2 Cable sizing | 36 |
| 3.4.3 Parallel cabinet cabling recommendations | 40 |
| 3.4.4 External maintenance bypass | 41 |
| 3.5 Connecting the UPS AC power cables | 42 |
| 3.5.1 Safety notes | 42 |
| 3.5.2 Preparing the UPS power cabling | 42 |
| 3.5.3 Connecting the UPS input power cables | 42 |
| 3.5.4 Preparing the output power cabling | 43 |
| 3.5.5 Connecting the UPS output cables | 43 |
| 3.6 Battery configuration | 45 |
| 3.6.1 Battery configuration options | 45 |
| 3.6.2 Battery cabling | 45 |
| 3.6.3 Internal battery configuration for ST-40 and ST-60 cabinets | 46 |
| 3.7 Customer Interface Board | 48 |
| 3.8 Parallel-cabinet control and configuration | 50 |
| 4: Operation | 51 |
| 4.1 Introduction | 51 |
| 4.1.1 Commissioning | 51 |
| 4.1.2 Operating procedure summary | 51 |
| 4.1.3 General warnings | 52 |
| 4.2 Operating instructions | 52 |
| 4.3 How to start the UPS system from a fully powered-down condition | 52 |
| 4.4 How to start the UPS system from the maintenance bypass | 54 |
| 4.5 How to transfer load to maintenance bypass then shut down the UPS system | 55 |
| 4.6 How to shut down the complete UPS system | 56 |
| 5: Maintenance | 57 |
| 5.1 Introduction | 57 |
| 5.2 User responsibilities | 57 |
| 5.3 Scheduled maintenance | 57 |
| 5.3.1 Preventative maintenance inspection | 57 |
| 5.3.2 System calibration | 57 |
| 5.3.3 Battery maintenance and testing | 58 |
| 6: Troubleshooting | 59 |
| 6.1 Alarms | 59 |
| 6.2 Menu, Commands, Event Log, Measurements | 59 |
| 6.3 Fault identification, rectification messages and alarms | 60 |
| 6.4 Contacting service | 60 |

| | |
|---|-----------|
| 7: Options | 61 |
| 7.1 Introduction | 61 |
| 7.2 Remote shut down | 61 |
| 7.3 Generator ON facilities | 62 |
| 7.4 UPS Monitoring and automated control software | 62 |
| 7.4.1 SNMP Card slots | 62 |
| 7.5 Remote interlock (for external maintenance bypass only) | 63 |
| 8: Specification | 64 |
| 8.1 Mechanical characteristics – UPS Cabinet | 64 |
| 8.1 System data | 65 |
| 8.1 UPS Power module data | 66 |
| 8.1 Battery data | 67 |
| 8.1 Standards | 67 |
| 8.1 Options | 67 |
| 8.1 Multi-cabinet configuration | 68 |

1 Safety

1.1 Description of symbols used in this manual



WARNING: The warning symbol is used where there is danger of an electrical shock, equipment damage or personal-injury.



CAUTION: The caution symbol is used to highlight important information to avoid possible equipment malfunction or damage.

1.2 User precautions



WARNING: Keep this manual with the UPS for future reference.



WARNING: The UPS and peripheral equipment must be installed and commissioned by suitably qualified and trained personnel who are aware of the potential shock hazards.



WARNING: Do not attempt to install this UPS system until you are satisfied that ALL the safety instructions and hazard warnings contained in this manual are read and fully understood.



WARNING: High leakage current!
Ensure that the UPS has been correctly earthed before you connect the mains power supply!



WARNING: This UPS must not be started-up or put into use without having first been commissioned by a fully trained engineer authorised by the manufacturer.



WARNING: All servicing must be performed by qualified personnel. Do not attempt to service the UPS yourself. You run risk of exposure to dangerous voltages by opening or removing the UPS-covers! Kohler Uninterruptible Power will assume no responsibility nor liability due to incorrect operation or manipulation of the UPS.



WARNING: The Kohler PW 8000DPA ST is a Class A UPS product (according to BS EN 62040). In a domestic environment the UPS may cause radio interference. In such an environment the user may be required to undertake additional measures.

2

General Description

2.1 General introduction

Congratulations on your purchase of the Kohler PW 8000DPA ST Uninterruptible Power Supply system.

2.1.1 Reliability and quality standards

Using a unique modular construction, the Kohler PW 8000DPA ST represents a completely new generation of medium power, 3 phase UPS-Systems, incorporating the latest technological developments in power engineering. High reliability, upgrade ability, low operating costs and excellent electrical performance are only some of the highlights of this innovative UPS solution.

Kohler Uninterruptible Power specialises in the design, building, installation and maintenance of Uninterruptible Power Systems. This compact and powerful UPS is just one example of our wide range of state-of-the-art power protection devices and will provide your critical equipment with a steady and reliable power supply for many years.

The criteria and methods we use in the design, manufacture, and maintenance of Uninterruptible Power Supply systems are certified to International Standard ISO 9001/EN 29001 and ISO 14001. A full UPS Specification is provided in Chapter 8 of this manual.

2.1.2 Advanced design features

Input booster technology

The UPS module's inbuilt advanced booster technology results in a perfect sinusoidal input power quality at 0.99 input power factor with a harmonic content of <4.5% THD(i) (10KW module) and <3% THD(i) (20KW module). This leads to a more reliable overall system operation and savings in generator and transformer sizing, as winding losses are minimised. It also means that traditional harmonic filters are no longer required.

The high power factor presented by the UPS on the incoming mains supply minimises cabling and fusing costs due to the minimised reactive power consumption. This, together with the accompanying low harmonic currents, provide the following benefits:

- No additional losses in wires and cables
- No extra heating of transformers and generators
- No over sizing of generators
- No false circuit breaker tripping and malfunction
- No erratic operation of computers, telecommunication, monitors, electronic test equipment etc.
- No resonance with power factor correction capacitors

Decentralized Parallel Architecture (DPA)

The Kohler PW 8000DPA ST system features Decentralized Parallel Architecture (DPA) paralleling technology that provides n+x redundancy without introducing a single-point-of-failure. Each power module is a fully functional, self-contained UPS that includes an individual battery charger, power inverter, bypass, CPU, control panel and separate battery configuration; making it a completely autonomous operating unit.

Flexible battery management

This equipment employs flexible battery charging management which avoids premature deterioration of battery life and provides preventive failure diagnostics.

The major benefits are:

- AC-ripple free battery charging due to a dc-dc charger separated from the rectifier and inverter.
- Wide range of number of battery blocks (30-50 blocks of 12V; depending autonomy times).

- Wide UPS input voltage operating window extends the battery life due to fewer discharge cycles.
- Battery discharge protection caused by load jumps.
- Proactive battery protection from false manipulations and inadequate charging voltages.
- Proactive battery failure detection thanks to Advanced Battery Diagnosis (ABD) algorithm.
- User selectable battery tests.
- Optional temperature compensated charging to enhance battery life.

2.1.3 Model range

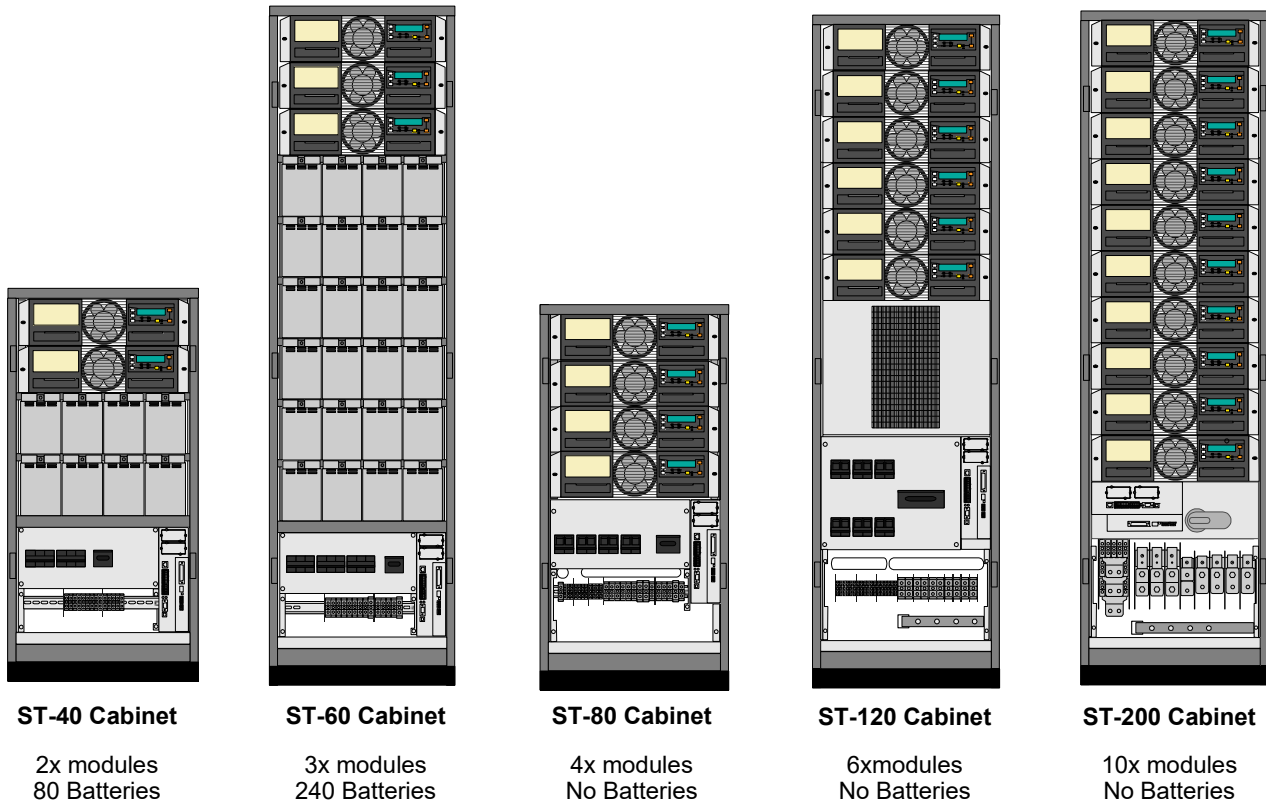

Figure 2.1 Kohler PW 8000DPA ST module configuration

The Kohler PW 8000DPA ST is a truly flexible system based on 10kW or 20kW UPS power modules which are assembled in a range of purpose-designed, free-standing cabinets containing up to ten UPS modules. The cabinet is rated according to the maximum number of 20kW modules that it can house – i.e. 40kW, 60kW, 80kW, 120kW and 200kW (see Figure 2.1). The 40kW and 60kW cabinets also contain the UPS batteries but these must be located externally in the case of the 80kW, 120kW and 200kW models. A range of matching battery cabinets is available.



Key Point: All the modules fitted within a cabinet must be of the same rating – i.e. it is not possible to mix 10kW and 20kW modules in the same parallel system.

The illustrations in Figure 2.1 show the various cabinets fully populated; however each of the systems shown can operate with as little as a single module fitted. Further power modules can be added to a vacant slot at a later time, without needing to power-down the system or in any way disrupt the load. This ‘hot-swappable’ technology also allows individual modules to be exchanged for testing or troubleshooting while the equipment is running without having to transfer the load to the bypass supply – depending on prevailing system redundancy and load demand.

Static switch

The static switch provides a means of connecting the UPS module output to the bypass line – which is connected to the UPS bypass input supply. Working in conjunction with the output contactor, the static switch control logic is used to transfer the UPS output between the inverter and bypass supply without a break in the load supply.

Note: A brief load break will occur if transferring from bypass to inverter following a bypass supply failure, or if the bypass/inverter are not synchronised when a transfer is demanded. (See 'Off Line Mode' in paragraph 2.2.3).

Automatic battery switch

If the UPS mains input supply fails, the battery is automatically connected to the input of the DC boost converter by means of an electronically controlled switch. This enables the inverter to continue its normal operation and maintain the UPS output load supply from battery power.

2.2.2 UPS Power module operational states

UPS ON-INVERTER mode

Figure 2.3 illustrates the UPS ON- INVERTER mode, which is considered the 'normal' mode of operation:

- The rectifier and DC boost converter are turned on to supply controlled DC power to the inverter input.
- The battery charger charges the battery.
- The inverter converts the DC supplied by the rectifier back into AC suitable for connecting to the load.
- The output contactor is turned on to connect the inverter output to the UPS output terminals to provide the load with processed power.

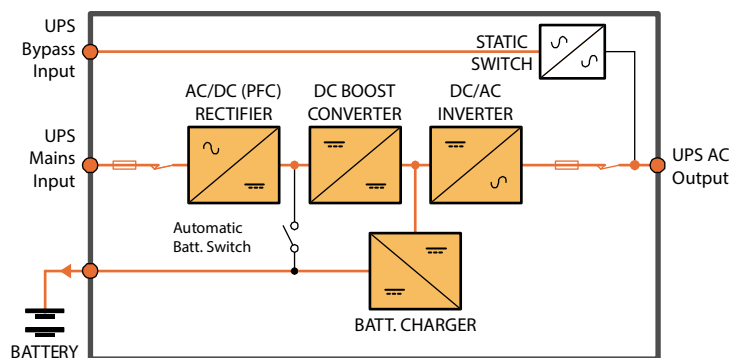

Figure 2.3 UPS ON-INVERTER

UPS ON-BATTERY mode

The UPS automatically changes to the ON- BATTERY mode if the mains input supply fails during normal (ON- INVERTER) operation:

- The battery discharges through the DC boost converter which regulates the battery voltage at the level required by the inverter.
- The inverter converts the DC supplied by the boost converter back into AC suitable for connecting to the load.
- The output contactor is turned on to connect the inverter output to the UPS output terminals to provide the load with processed power.

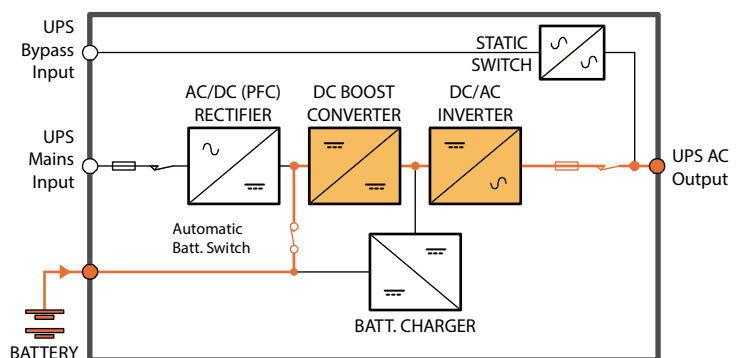

Figure 2.4 UPS ON-BATTERY

UPS ON-BYPASS mode

This mode can be selected by the operator as part of the system operating procedure. It is also entered following certain fault occurrences such as a UPS output overload:

- The load is connected to the raw mains input supply through the bypass arm of the static switch.
- The rectifier and inverter remain powered up and in operational readiness to be brought into use.
- When operating in this mode the load is not protected against any mains input supply disturbances or loss.

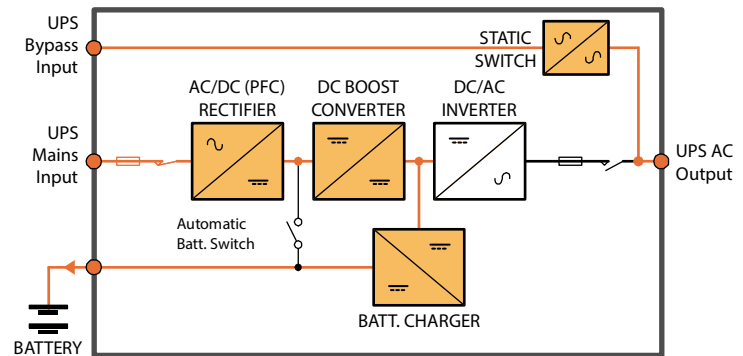

Figure 2.5 UPS ON-BYPASS

2.2.3 UPS system operation

Summary of UPS module operating modes

UPS installations are generally categorised as being either 'ON-LINE' or 'OFF-LINE/On stand-by' systems; and the Kohler PW 8000DPA ST can be configured to operate in either mode. The two systems are described below.

ON-LINE UPS system

An 'ON-LINE' system provides the highest degree of load protection, especially in the event of a mains supply disturbance or complete failure, and we always recommended its use if the critical load (e.g. computer system) will not tolerate even a very brief supply interruption.

When the Kohler PW 8000DPA ST is used as an 'ON-LINE' UPS it is configured to normally operate in the ON-INVERTER mode, as shown in Figure 2.3. In the event of a mains supply failure, the UPS changes to its ON-BATTERY mode (Figure 2.4) without affecting its output supply – i.e the changeover to battery operation is totally transparent at the UPS output. The UPS then continues to provide its rated output until the battery discharges to a low cut-off point, at which time the UPS will attempt to switch to its 'on bypass' mode and, if the bypass is unavailable, then it will shut down in a controlled manner. An audible and visual alarm will warn that the battery is discharging to enable the operator to take any necessary intervention to protect the load integrity.

It is usual, especially in larger installations, to provide the UPS with an alternative input supply from a standby generator which starts automatically following a mains supply failure; and where this is implemented the batteries discharge for a short period only, until the generator comes on-line. This not only avoids the UPS shutting down due to discharged batteries but also increases the battery life cycle.

If the UPS experiences an internal fault during ON-LINE operation, the inverter is turned off and the static switch transfers the load to the bypass line (Figure 2.5) automatically and without interruption provided the inverter and bypass supplies are synchronised. In the event of an output overload, the inverter can supply the load for a limited time, depending on the overload severity, and if the permitted time is exceeded the load is transferred to bypass. The additional power available from the bypass supply will attempt to clear the overload but if it persists it will ultimately rupture the bypass supply fuses. If the overload condition clears while operating on bypass the load is re-transferred to the inverter and the UPS will return to its normal ON-LINE mode of operation.

OFF-LINE (On stand-by) UPS system operation

When the Kohler PW 8000DPA ST is used as an 'OFF-LINE' UPS it is normally operated in its ON-BYPASS mode (Figure 2.5) with the load supplied via the bypass line. However the rectifier, DC boost converter and battery charger are still powered up to maintain battery charging, and the inverter section is turned on and operating on standby.

In the event of a bypass supply failure, the inverter is immediately brought on line and the load is transferred from the bypass line to the inverter by the static switch within 3 to 5 milliseconds. If the UPS bypass and mains inputs are connected to separate sources and the mains supply is still live when the transfer takes place then the UPS will operate in its ON-LINE mode (Figure 2.3). However, if these supplies are connected to a common source the UPS will immediately revert to its ON-BATTERY mode (Figure 2.4).

When the bypass supply returns to normal, the load is re transferred back to the bypass line and the inverter returns to its standby operation.

Operating in this mode is slightly more energy efficient than operating in the ON-LINE mode due to the reduced rectifier and inverter losses during normal system operation; and it is sometimes referred to as the “ECO” (economy) mode. However, this mode is recommended only if the connected load equipment can tolerate power interruptions of up to 3~5 ms during the transfer period.



WARNING: The ON-LINE mode should always be used for critical load protection.

Control panel mimic indications

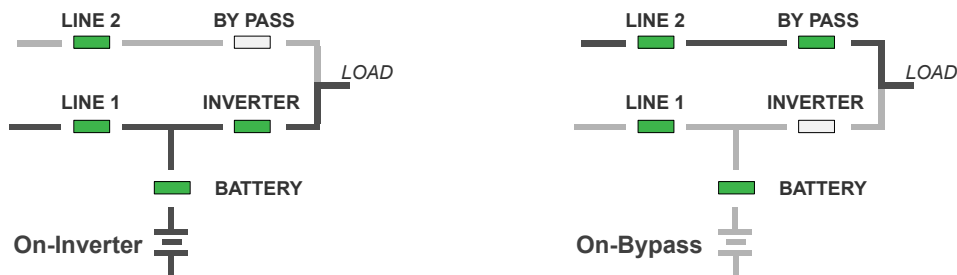

Figure 2.6 Control panel mimic indications

2.2.4 Parallel system operation

The power output from all the modules fitted in a UPS cabinet are connected in parallel at the cabinet’s output terminals, and the electronics built into each module’s control system ensures that:

- The UPS modules are always frequency-synchronised to each other – and to the bypass supply (when present).
- The UPS modules equally share the load current.
- The static bypass operation is synchronised such that, for example, if the operator selects ‘Bypass’ mode the static switch in ALL the modules change over in unison.

It is also possible to connect the outputs from several UPS cabinets in parallel to increase the overall system capacity or provide additional module redundancy – the maximum number of cabinets that can be paralleled is shown in the table below.

| | ST-40 | ST-60 | ST-80 | ST-120 | ST-200 |
|--|-------|-------|-------|--------|--------|
| Number of UPS power modules per cabinet | 2 | 3 | 4 | 6 | 10 |
| Parallel cabinets per system | 4 | 4 | 4 | 3 | 2 |
| Max number of UPS power modules per system | 8 | 12 | 16 | 18 | 20 |
| Max system capacity (without redundancy) | 160 | 240 | 320 | 360 | 400 |

When two or more cabinets are connected in parallel all the power modules within the cabinets are effectively paralleled together – for example if three fully populated ST-120 cabinets are paralleled then the system effectively contains 18 fully paralleled UPS power modules.

This requires the same degree of parallel control concerning synchronisation, load sharing, bypass switching etc. as described for the modules operating in an individual cabinet; and in order to achieve this a parallel communication bus is daisy chained between the cabinets as illustrated in Figure 2.7.

System expansion

Some UPS applications present a low initial power requirement which increases over time as the application grows; and it is therefore essential that the installed UPS system can be expanded to meet the growing demand without compromising the existing load. This requirement is well met with the 'hot swappable' feature of the Kohler PW 8000DPA ST UPS power modules, whereby additional module(s) can be inserted into a vacant slot in an existing cabinet. If a system expansion requires an additional cabinet the system will have to be shut down while the cabinet is installed.

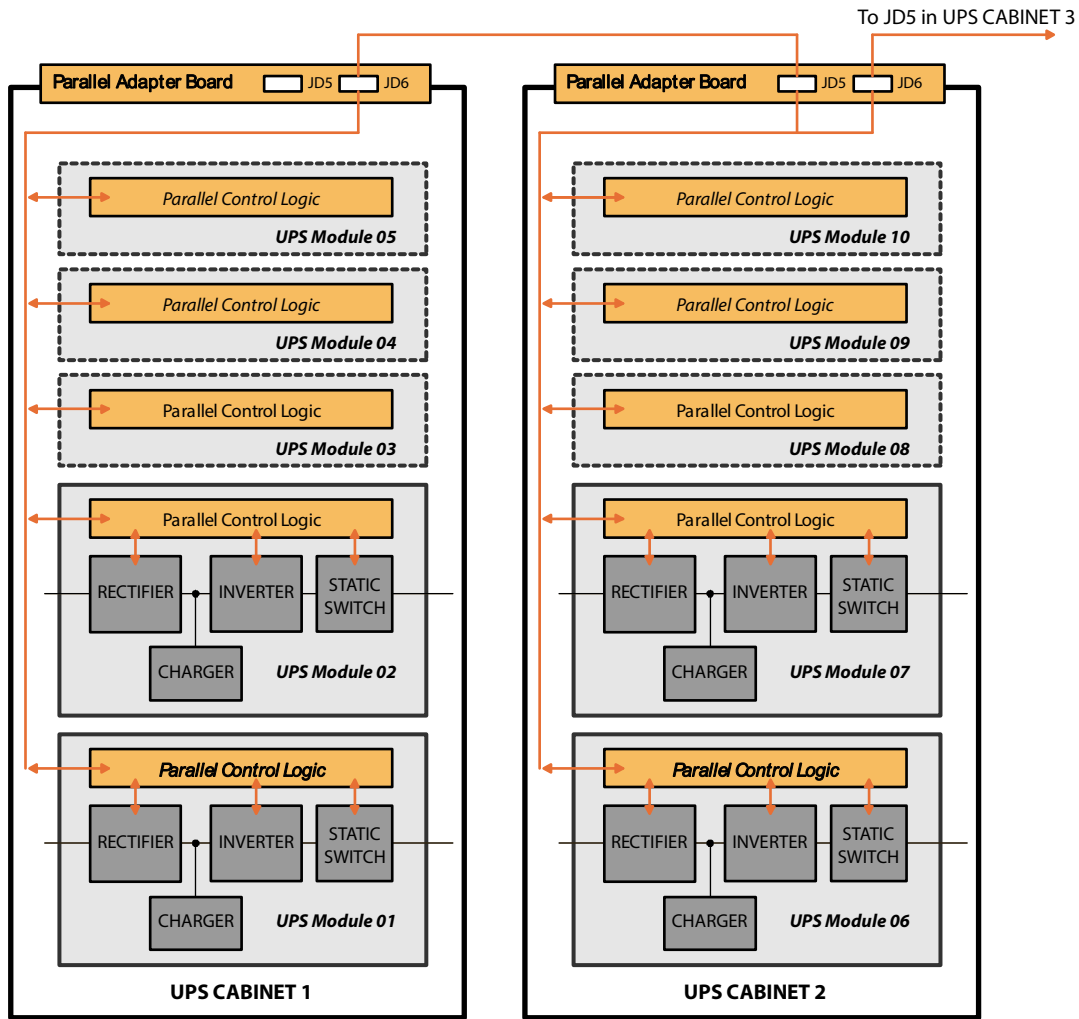

Figure 2.7 Parallel system control



Key Point: When planning a multi-cabinet system, it is not necessary to fully populate one cabinet with UPS modules before installing the next cabinet. For example, if it is known at the outset that the eventual load is likely to exceed 300 KW it makes sense to install and cable-up four ST-80 cabinets and distribute the initially required number of modules between them.

‘Capacity’ system

When a system is described as a ‘Capacity system’ it implies that the potential full load requires ALL the UPS power modules to be operational – i.e. if one module trips off line due to a fault, the remaining modules will transfer the load to the bypass supply and the load will no longer be protected against supply aberrations.

‘Redundant’ system

If a system is designed with module redundancy it must contain at least one UPS power module over and above that necessary to power the applied load.

Using the example given above, four fully populated ST-80 cabinets (16 modules = 320kW) would present one redundant module for a 300kW load. Under normal circumstances with all 16 power modules on-inverter they would each provide 18.75kW when full load is applied, but if one module fails or is taken off-line, the remaining 15 modules can sustain the load by each providing their rated 20kW output. The ability to lose one module yet still supply the rated load with processed, backed-up power significantly increases the overall system reliability.

Note: A parallel system operating with a redundant module is known as an 'N+1' system.

2.3 Module component identification

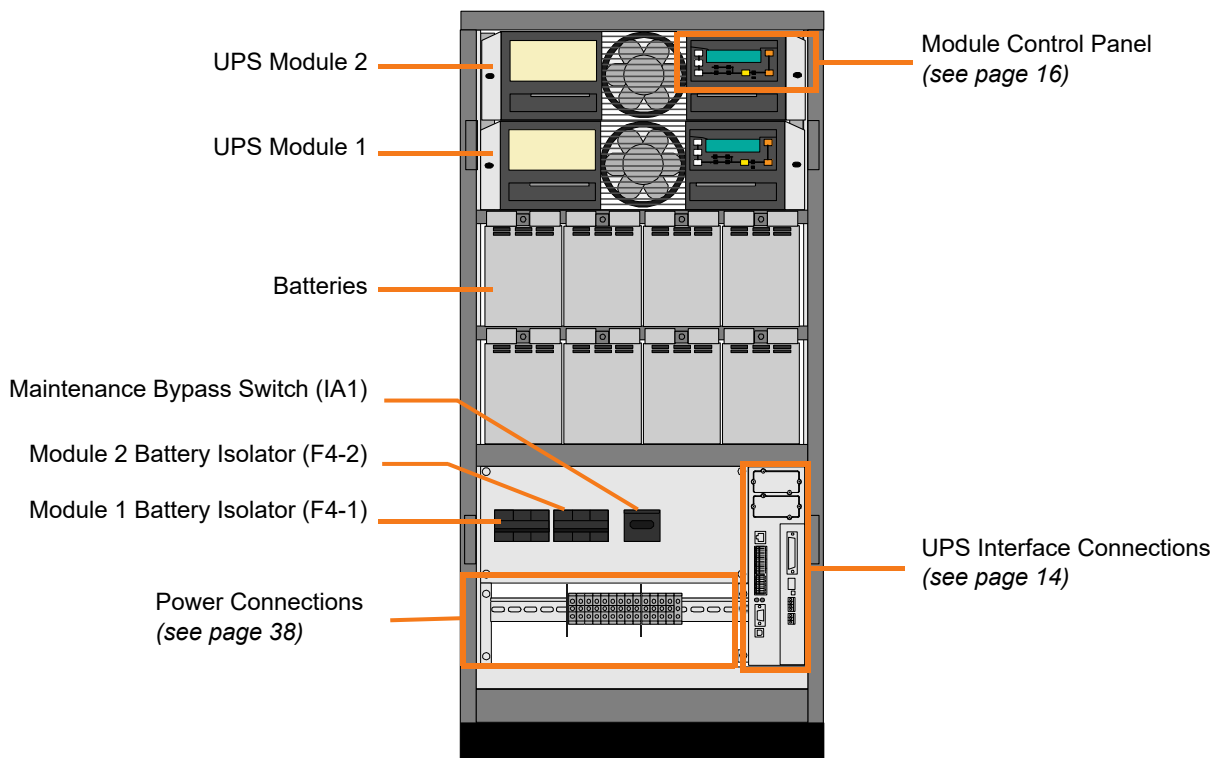

Figure 2.8 ST-40 Cabinet front view

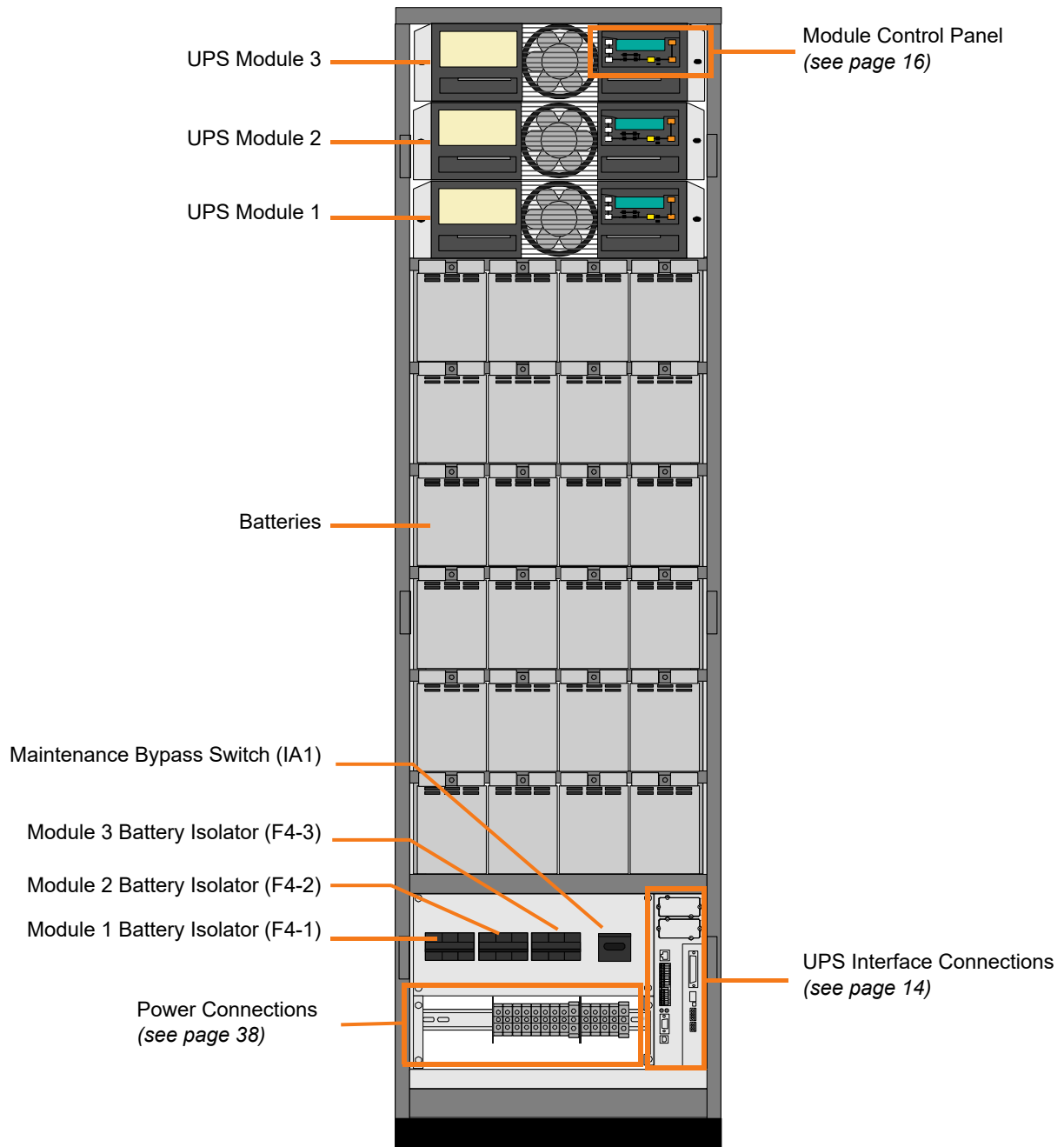

Figure 2.9 ST-60 Cabinet front view

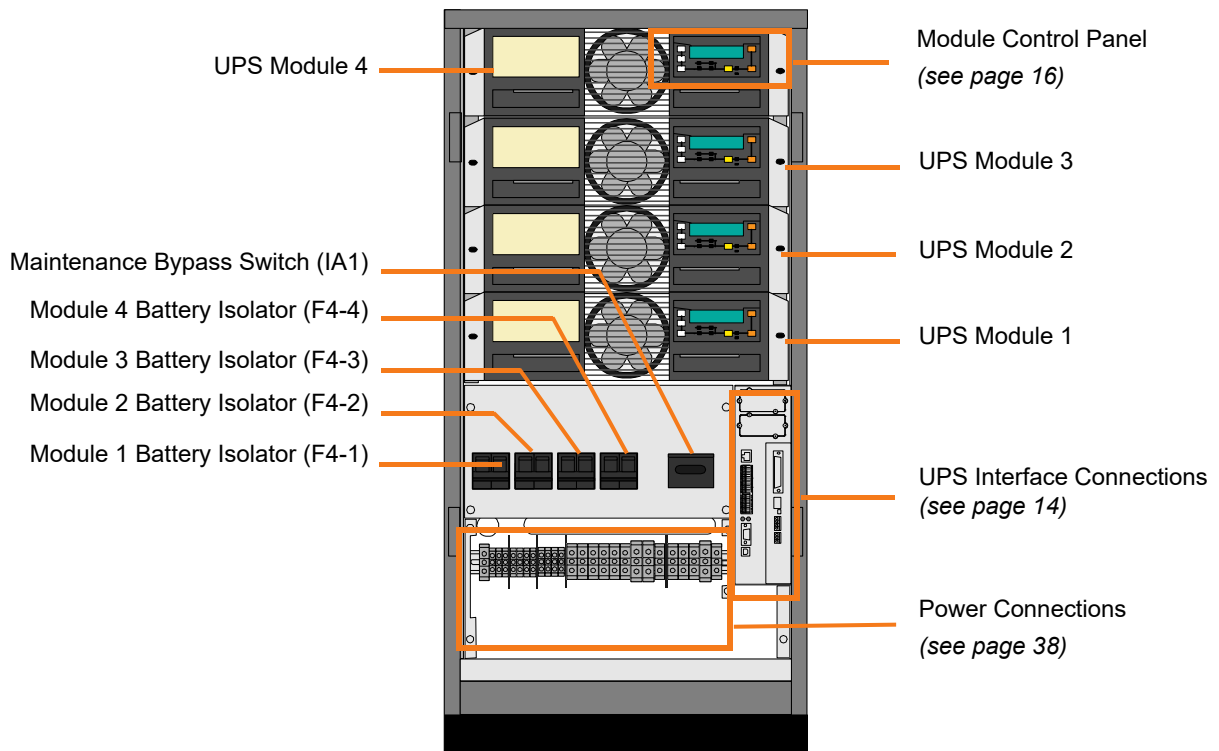

Figure 2.10 ST-80 Cabinet front view

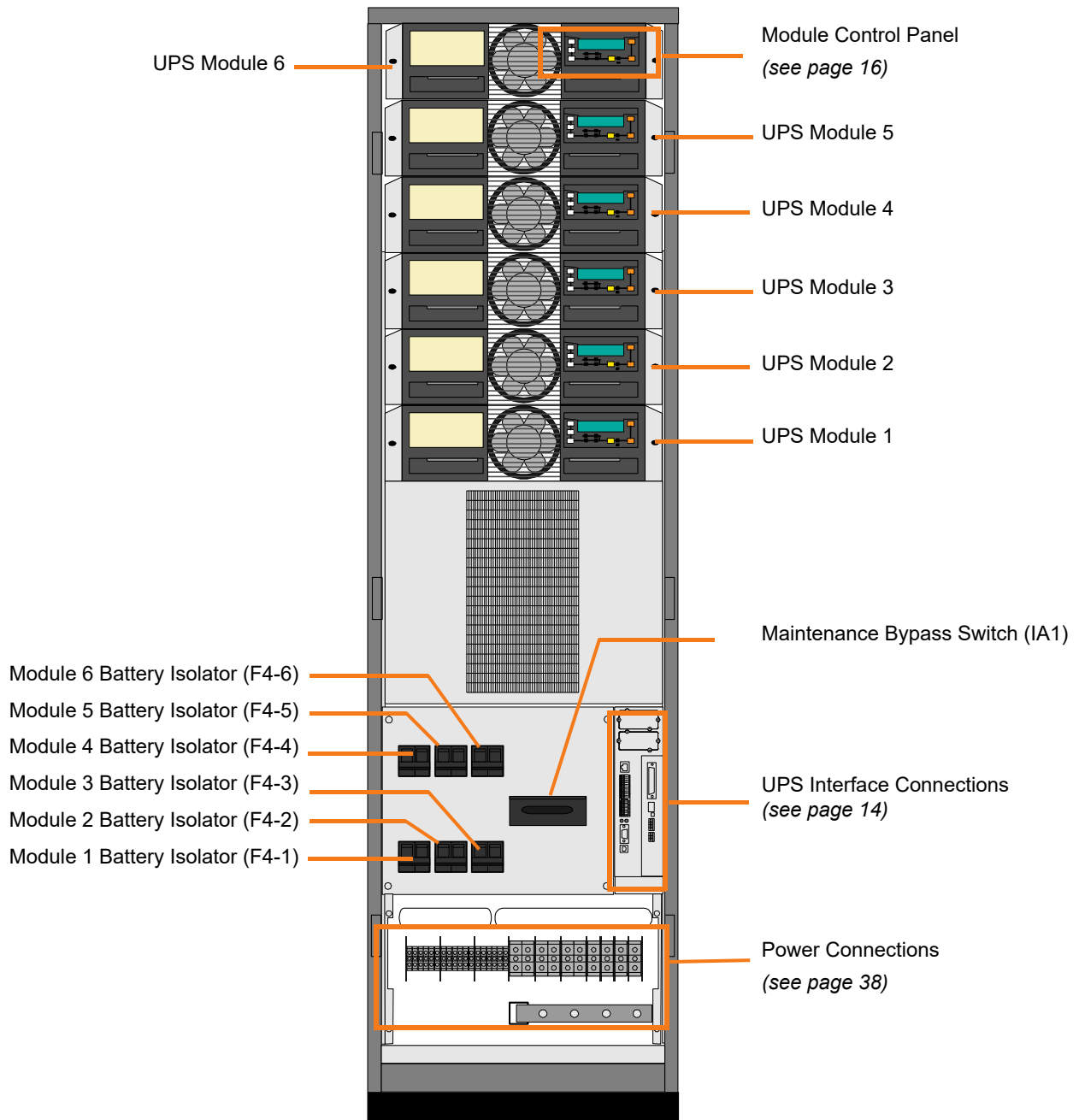

Figure 2.11 ST-120 Cabinet front view

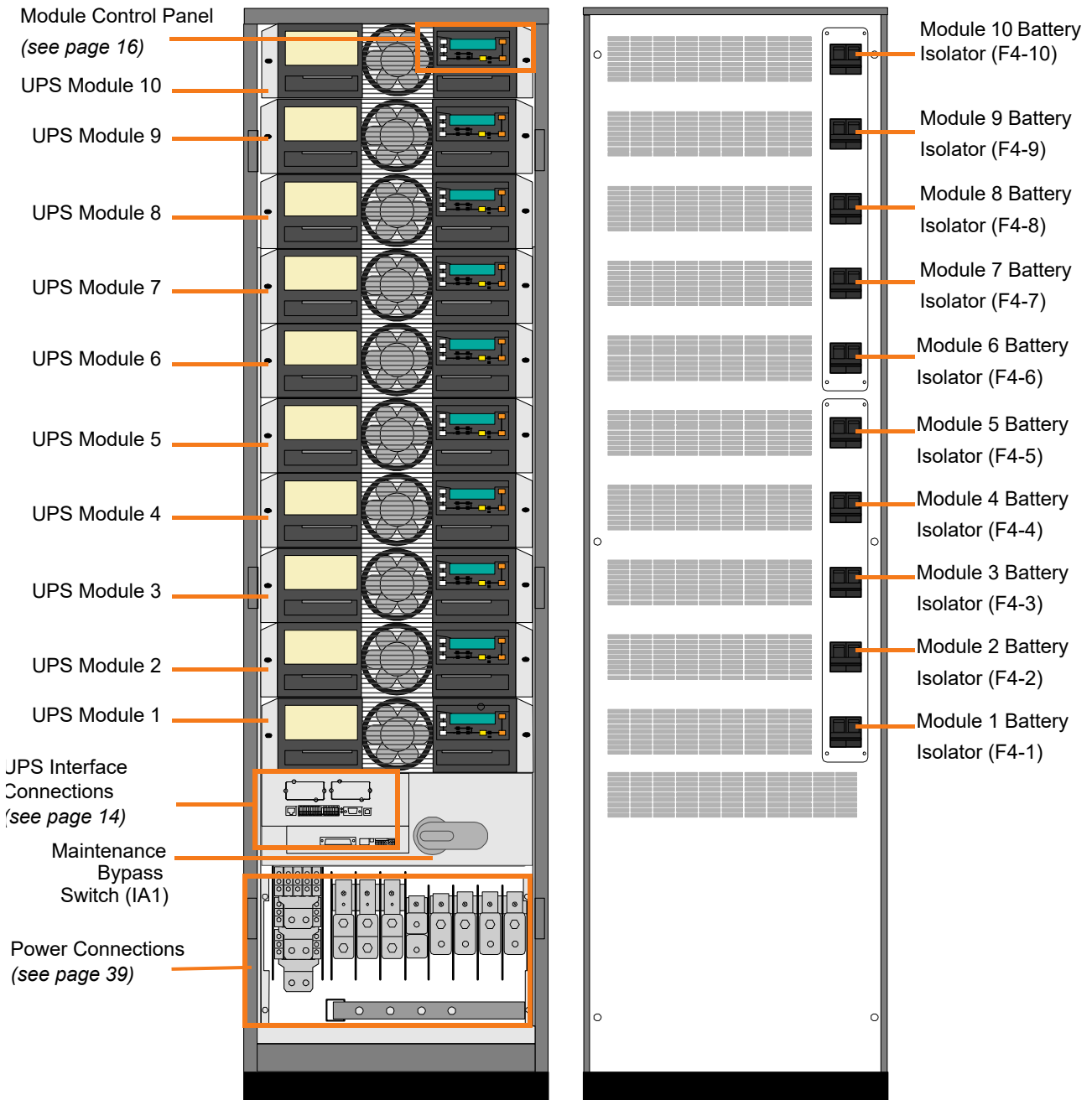

Figure 2.12 ST-200 Cabinet front and back view

2.4 UPS Interface boards

Two interface boards are fitted in the lower part of the UPS cabinet, adjacent to the Maintenance Bypass switch. One is the Customer Interface Board, which provides a means of connecting the UPS cabinet to a range of external monitoring and control facilities. The other is the Parallel Interface Board which contains the connections used to control and monitor the cabinets when connected as part of a parallel cabinet system.



Key Point: The Parallel Interface Board is part of the factory-fitted 'paralleling kit' and is installed only in UPS cabinets used in a parallel system.

2.4.1 Customer Interface Board

The Customer Interface Board, illustrated in Figure 2.13, provides a number of input/output interface connections that can be used by the customer to facilitate external monitoring and control of the UPS system – e.g. as part as a building management system (BMS).

The available interfaces include:

- Two smart slots – e.g. CS141
- RS485 interface via an RJ45 network connector (JR2)
- Relay operated dry-port alarm outputs for remote monitoring (X2)
- Dry-port inputs for customer remote control options (X1)
- RS232 computer interface for remote monitoring/control applications (JD1)
- USB port for computer monitoring applications

The dry-port connection details are provided in the Installation chapter of this manual (*see paragraph 3.7*).



Key Point: When the UPS cabinet is installed as part of a parallel system the Customer Interface Board I/O is disabled in the 'slave' cabinets if the system 'Multidrop' application is enabled.

2.4.2 Parallel Interface Board

The Parallel Interface Board, illustrated in Figure 2.13, facilitates the connection of the parallel control bus cables between the cabinets in a parallel system. The parallel bus cables are connected to a 'Parallel Adapter' board which is fitted to JD8.

Two terminal blocks are fitted to the Parallel Interface Board.

- Terminal block X1: The PW8000DPA ST has an optional 'Synchronisation Feature' which enables it to synchronise to any other UPS system. This feature requires other factory-installed modifications and, when enabled, the 'line' supply of the external source is connected to X1 where it acts as a synchronisation reference.
- Terminal block X2: Is connected to the auxiliary contacts of an optionally installed external maintenance bypass switch and/or external output isolator. This allows the UPS to detect the status of the external switch and react accordingly. Details of the terminal block connections as shown in paragraph 3.8

In a parallel system, one cabinet acts as the 'master' cabinet and the remaining cabinets act as the slave. The master/slave configuration is set by DIP switch S1-6.

Multidrop

The optional 'Multidrop' feature, which is available only in a parallel system, allows the Customer Interface Board in the 'master' cabinet to collect data/messages from the other system cabinets via the parallel control bus cables and Parallel Interface Boards.

The received data is then processed at a centralised point on the 'master' Customer Interface Board and made available to the user directly on the RS232 port (JD1). It is also transmitted to the CS141 card if inserted in the relevant slot.

Note that when the Multidrop feature is used the I/O facilities of Customer Interface Board in the 'slave' cabinets are all disabled, but the Customer Interface Board fitted to the 'master' cabinet remains fully functional.

ST200 Cabinet

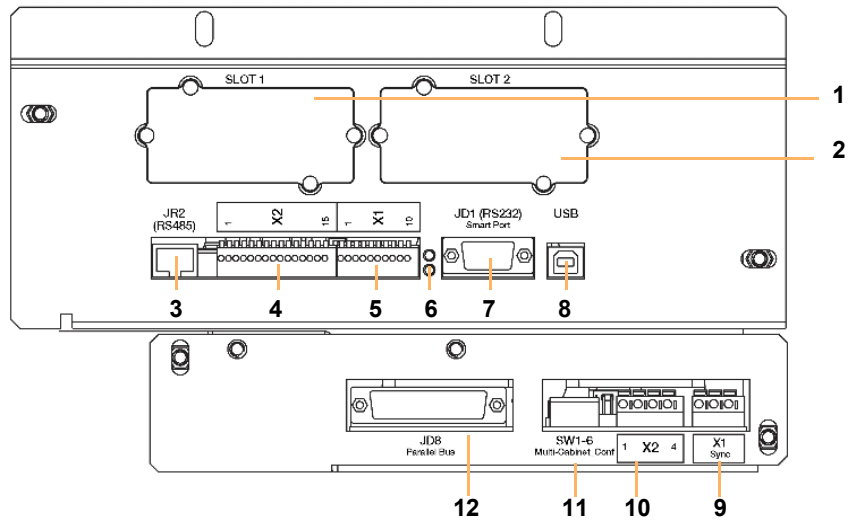

ST40-120 Cabinet

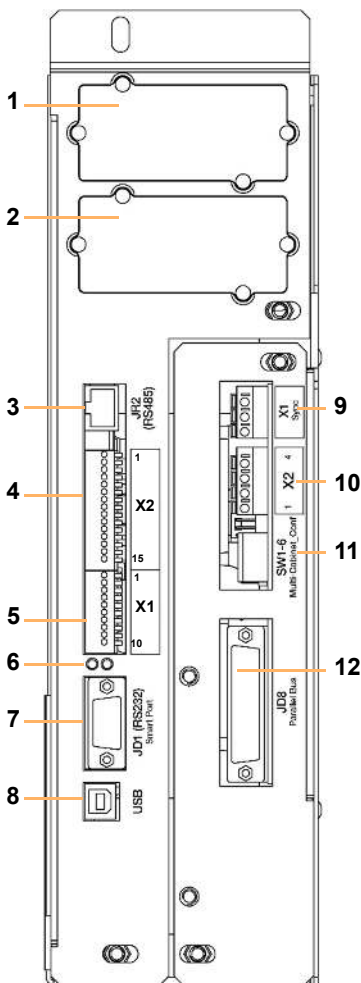

| Customer Interface Board | | |
|--|--------|---|
| 1 | SLOT 1 | Slot for optional Modem/Ethernet card ONLY. |
| 2 | SLOT 2 | Slot for optional SNMP card ONLY. |
| 3 | JR2 | RJ45 Port: |
| 4 | X2 | Customer output dry ports: Up to 5 output dry contacts used for signalling of the status of the UPS system (e.g. Mains failure, load on inverter, battery low, common alarm). |
| 5 | X1 | Customer input dry ports: Up to 5 input dry contacts used for remote Shut Down and Generator Operation facilities, battery temp sensor or bespoke customer function. |
| 6 | LEDs | Status LEDs: 2 LEDs that indicate the Interface Board operational status. |
| 7 | JD1 | RS232 Smart port computer interface: Sub D9 female connector provides an RS232 user interface for remote systems monitoring. |
| 8 | USB | Standard USB interface: Provides a USB user interface for remote systems monitoring. |
| Parallel Interface Board (fitted in a parallel UPS cabinet only) | | |
| 9 | X1 | Sync Input: Allows external synchronisation control source. |
| 10 | X2 | External manual bypass: Auxiliary signals from external manual bypass switch and external output breaker providing open/close status information for parallel system configuration |
| 11 | S1-6 | Multi-cabinet configuration DIP switch: Used to configure the cabinet position in a parallel system. |
| 12 | JD8 | Parallel bus: Attached to the Parallel Adapter Board, which provides the parallel communications bus in a parallel system |

Figure 2.13 UPS Interface Boards

2.5 Module control panel

Figure 2.14 illustrates the control panel located on the front of each UPS module.

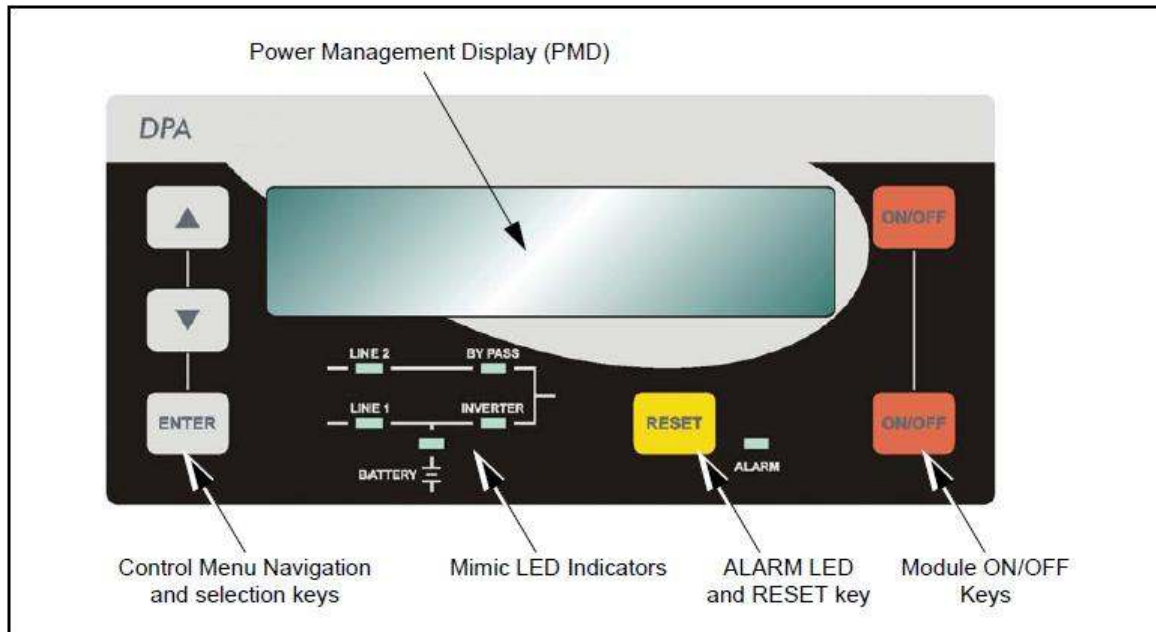

Figure 2.14 Module control panel

2.5.1 Power Management Display (PMD)

The 2 x 20 character LCD Power Management Display simplifies communication with the UPS and also provides UPS monitoring information (see paragraph 2.6).

The menu driven LCD enables the operator to:

- Access the 'event register'.
- Monitor the input and output voltage, current, frequency & power.
- Monitor the battery run time.
- Perform commands such as UPS start-up and shut-down and transfer the load between INVERTER and BYPASS.
- Access diagnostic and test facilities (service mode).
- Adjust the UPS configuration and operating parameters (service mode).

2.5.2 Mimic LED indicators

The mimic diagram LEDs indicate the operational status of the UPS power blocks, and change colour between Green and Red (and OFF) to indicate the active power flow through the UPS.

- LINE 1 (rectifier) and LINE 2 (bypass) indicate the availability of the UPS mains and bypass input power supplies.
- INVERTER and BYPASS, when green, indicates which of the two sources is providing the critical load power.
- The BATTERY LED indicator flashes when the battery is supplying the load – e.g. following a mains failure.
- The ALARM LED is a visual indication of an internal or external alarm condition. When activated, it is accompanied by an audible warning.

LED Indication summary

| INDICATOR | STATUS | INTERPRETATION |
|-----------|--|--|
| LINE 1 | GREEN RED | Mains input supply available Mains input supply not available |
| LINE 2 | GREEN RED OFF | Bypass input supply available Bypass input supply faulty or not present UPS is powered OFF |
| ALARM | OFF RED | No alarm condition Alarm condition detected (still present if unable to cancel buzzer) |
| INVERTER | GREEN RED OFF | Load on inverter Inverter fault, not available or locked out Inverter not operating (switched OFF, load on bypass) |
| BY-PASS | GREEN RED OFF | Load on bypass Static bypass fault, not available or locked out Bypass not operating (switched OFF, load on inverter) |
| BATTERY | GREEN Flashing GREEN Flashing RED RED | Battery OK and charging Battery is supplying the load (normal during mains failure) Battery on load with 'BATTERY DISCHARGED' message Battery fault, disconnected or fully discharged |

2.5.3 Operator keys

The operator keys allow the user to:

- Make settings and adjustments via the menu driven LCD display.
- Start-up and shut-down the Module and transfer the load between inverter and bypass.
- Monitor and display the UPS operating voltages, currents, frequencies and other values on the LCD display.

Key function summary

| KEYS | FUNCTION |
|------------------|---|
| ON/OFF ON/OFF | Used to switch-on or switch-off the UPS. Both keys must be pressed simultaneously (for less than 1 second). |
| UP (▲) | Scroll upwards through a displayed menu. |
| DOWN (▼) | Scroll downwards through a displayed menu. |
| RESET | Cancels the audible alarm. If the alarm condition was transient the ALARM LED will also extinguish, otherwise it will remain ON (red) until the alarmed condition is cleared. |
| ENTER | Confirms (selects) a chosen menu item. |

ON/OFF Start-up and shut down buttons

The Module can be switched ON or OFF by simultaneously pressing both ON/OFF buttons on the control panel. The inclusion of two buttons is designed to prevent accidental Module start-up or shut down.

During normal operation, pressing the two ON/OFF buttons will immediately shut down the UPS module.

- In a single module installation this will disconnect the UPS from the load.
- In a parallel module system the UPS module will shut down; however, the load may or may-not transfer to the bypass supply in the remaining module(s) depending on the prevailing load and available module redundancy.

Note: To shut down all the modules in a parallel system you must press both ON/OFF buttons on every module!



CAUTION: If the OFF buttons are operated on all the UPS module while the UPS is not on Maintenance Bypass it will interrupt the load power supply.

2.6.3 Event log menu screen

| DESCRIPTION | LCD-DISPLAY |
|--|---|
| 1. Logging Control; a log of the last 64 events is stored in the Power Management Display. | <div style="border: 1px solid black; padding: 2px;"> 01 05-10-15 14-38-56 LOAD TO INV. </div> |
| 2. Every stored event is identified with a sequential number and time stamp. | <div style="border: 1px solid black; padding: 2px;"> 02 05-10-15 14-38-59 LOAD TO BYP. </div> |
| 3. All events and alarms are indicated with their date and time of appearance. | <div style="border: 1px solid black; padding: 2px;"> 03 05-10-15 14-39-14 LOAD OFF </div> |

2.6.4 Measurements menu screen

| DESCRIPTION | LCD-DISPLAY |
|---|--|
| 1. Battery Runtime | BATT. RUN TIME (MIN) 00h 00mm |
| 2. UPS-Output Frequency | OUTPUT FREQUENCY (HZ) 50.00 |
| 3. Bypass Frequency | BYPASS FREQUENCY (HZ) 50.00 |
| 4. Battery Voltage | BATTERY VOLTAGE (V) +0.0 - 0.0 |
| 5. Battery Charger Current | BATT. CHARGE CUR. (A) + 0.0 - 0.0 |
| 6. Battery Discharge Current | DISCHARGE CURRENT (A) 00.00 |
| 7. Rectifier (mains) Input Voltage (all three phases) | RECTIFIER VOLTAGE (V) 000 000 000 |
| 8. Bypass Input Voltage (all three phases) | BYPASS VOLTAGE (V) 000 000 000 |
| 9. Output Voltage (all three phases) | OUTPUT VOLTAGE (V)0 000 000 000 |
| 10. Output Current (all three phases) | OUTPUT CURRENT (A)0 0.00 00.00 00.00 |
| 11. Active Output Power (all three phases) | ACTIVE POWER (KW) 00.00 00.00 00.00 |
| 12. Reactive Output Power (all three phases) | REACTIVE POWER (kVAr) 00.00 00.00 00.00 |
| 13. Apparent Output Power (all three phases) | APPARENT POWER (KVA) 00.00 00.00 00.00 |
| 14. Output Power% (all three phases) | OUTPUT POWER (%) 00.00 00.00 00.00 |
| 15. Battery capacity | BATT. CAPACITY (%) 00.00 |
| 16. Battery temperature (only if battery temp probe fitted) | BATTERY TEMPERATURE 20 |
| 17. Module temperature (for BOOSTER and INVERTER) | MODULE TEMP. BST/INV 20.0 20.0 |

2.6.5 Commands menu screen

| DESCRIPTION | LCD-DISPLAY |
|--|--|
| 1. Transfer Load to inverter | → LOAD TO INVERTER LOAD TO BYPASS |
| 2. Transfer Load to bypass | → LOAD TO BYPASS PERFORM BATT. TEST |
| 3. Battery Test | → PERFORM BATT. TEST PERF. DEEP BAT. TEST |
| 4. Perform Deep Battery Test | → PERF. DEEP BAT. TEST ABORT BATT. TEST |
| 5. Abort Battery Test – applies to 'normal' and 'deep' tests | → ABORT BATT. TEST PERFORM ALARM TEST |
| 6. Alarm test – activates buzzer and dry contact 'alarm' | → PERFORM ALARM TEST |

2.6.6 UPS Data menu screen

| DESCRIPTION | LCD-DISPLAY |
|---|---------------------------------|
| 1. These general UPS Data are installed at the manufacturing plant. | UPS SERIAL NUMBER nn-nnnnnn |
| 2. Manufacturing date | DATE OF MANUFACTURE 15-08-15 |
| 3. EPROM Version | EPROM VERSION V-000 |
| 4. Hardware Version | HARDWARE VERSION 00000000 |
| 5. Activate dynamic password | DYNAMIC PASSWORD NO |
| 6. Current Date and Time | dd-mm-yyyy hh:mm:ss |

2.6.7 Set-up User menu screen

| DESCRIPTION | LCD-DISPLAY |
|----------------------------------|---|
| 1. Set-up language | → SET LANGUAGE SET DATE AND TIME ENGLISH FRENCH SPANISH GERMAN POLISH RUSSIAN PORTOGUESE DUTCH |
| 2. Set-up Date and Time | → SET DATE/TIME SET BATTERY TEST DD-MM-YY HH-MM-SS |
| 3. Set-up battery test | → SET BATTERY TEST SET GENERATOR OP. DAY OF MONTH (1-31) HOUR OF DAY (0-23) REPETITIVE (Y/N) 000 |
| 4. Set-up operation with Gen-Set | → SET GENERATOR OP. BATT. CHARGE LOCK YES/NO BYPASS LOCK YES/NO |

2.6.8 Set-Up Service menu screen

| DESCRIPTION | LCD-DISPLAY |
|---|------------------------------|
| 1. This Menu is reserved for authorized service engineers only. | → SET-UP SERVICE PASSWORD |
| 2. Type in password | → PASSWORD* |

2.7 Optional system control panel

The system control panel is an optional component which is fitted to one UPS cabinet, usually the 'master' UPS, in a parallel cabinet system.

It contains a microprocessor-based TFT touch-screen display which enables the operator to monitor the status of the overall UPS system as well as each individual UPS module. It also allows the operator to transfer the load between the inverter and bypass. All other UPS module-level commands must be performed from an individual module's control panel. By having both control panels in place, working at 'module' and 'system' level, the UPS offers enhanced user friendliness without compromising on robustness.

Using the touch-screen, the operator can:

- check system's operational status and measurements
- execute system-level commands
- monitor the power flow through the UPS system
- check alarm and events history
- silence alarms
- adjust programmable parameters
- view the battery status



Figure 2.15 System control panel

The display turns on automatically when the first UPS power module is energised; and after a few seconds of initialisation it displays the default module mimic screen shown in Figure 2.16.

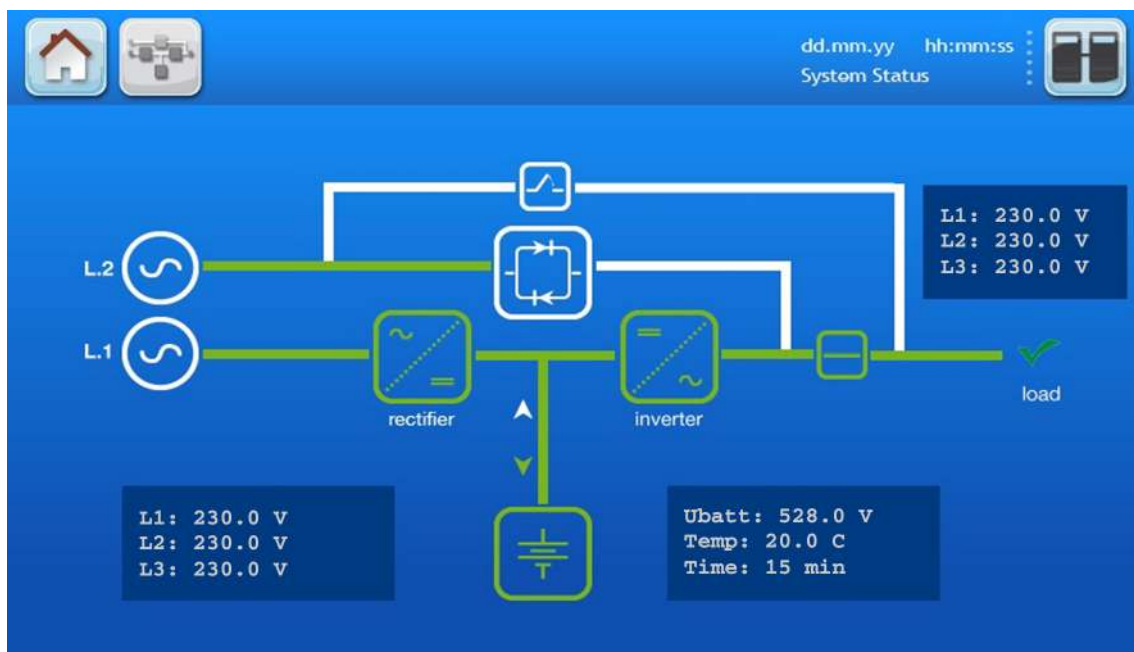

Figure 2.16 System control panel – default display

2.7.1 Display header bar

A navigation and status bar is displayed in the header area of every screen.

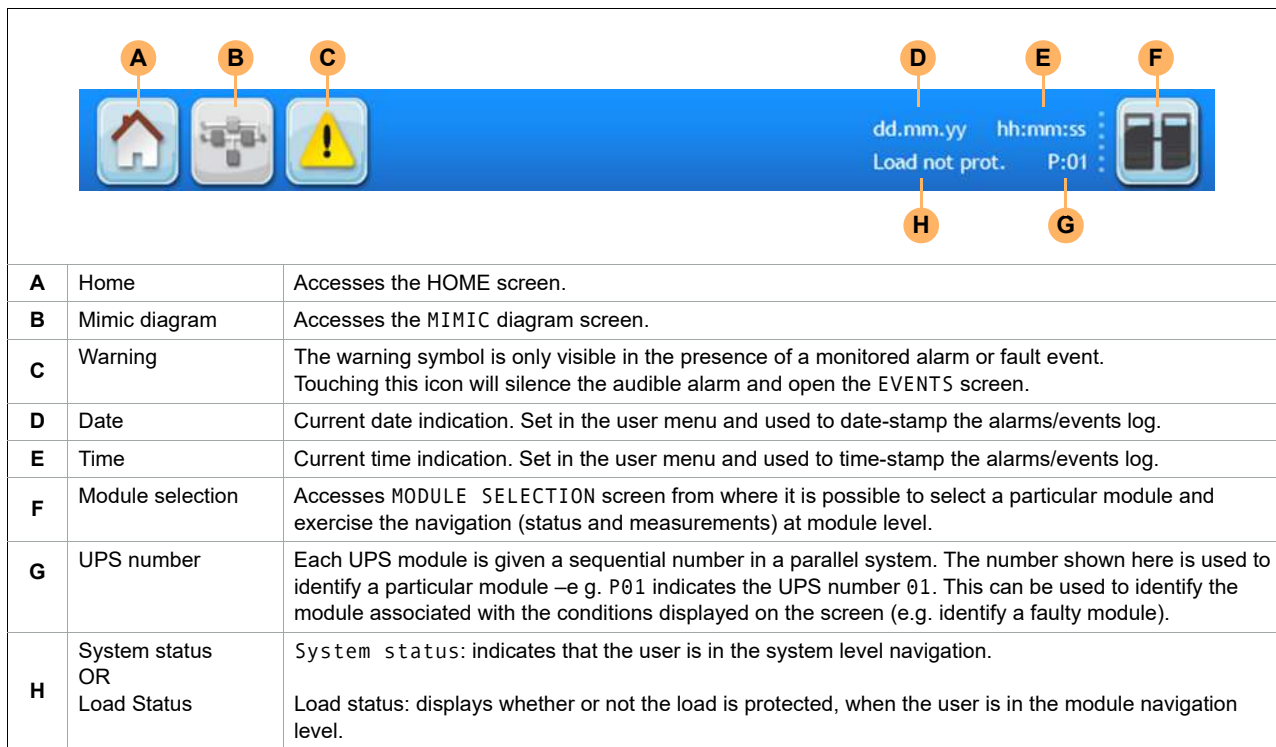
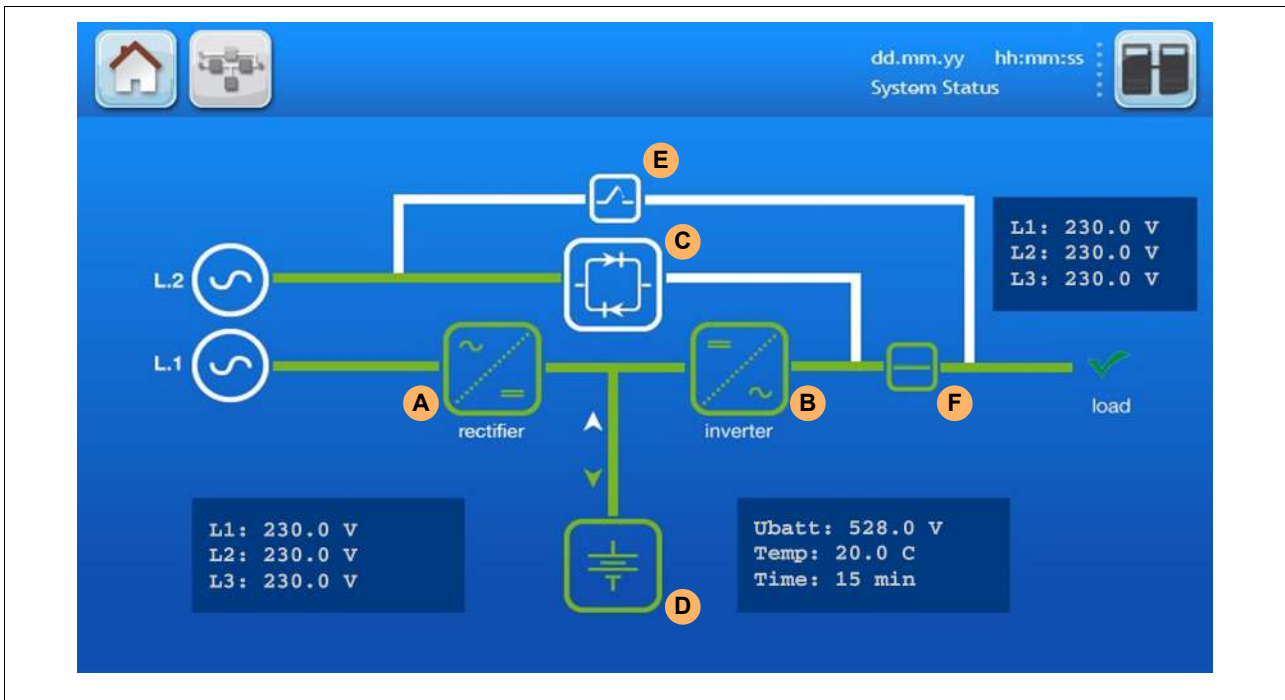

Figure 2.17 Navigation and status header bar

2.7.2 Mimic diagram – system level

The system level mimic diagram is the default screen. It shows the power flow through the UPS system and indicates its operational status – in either a single cabinet or multi-cabinet configuration.

The operational status of each block is identified by its line colour, as shown below in Figure 2.18, with the green connecting lines indicating the power flow in the system.



| | | | |
|----------|---------------------------------|---------|--|
| A | Rectifier | Green: | Rectifier is on. |
| | | Red: | Rectifier is switched off. |
| B | Inverter | Green: | Load is on inverter. |
| | | Red: | Inverter is switched off. |
| C | Bypass | Green: | Load is on bypass (or the system is operating in eco-mode). |
| | | Red: | Bypass is switched off. |
| D | Battery | Green: | Battery is charging or discharging (the direction of flow is indicated by the adjacent green arrowheads.) |
| | | Yellow: | Battery is not charging nor discharging. |
| | | Red: | Battery is in fault condition or is discharged. |
| E | Maintenance Bypass Isolator IA1 | Yellow: | Load is on maintenance bypass |
| | | White: | Maintenance bypass opened |
| F | Output Switch | Green: | Output Switch is closed (Position ON) |
| | | White: | Output Switch is opened (Position OFF) |

Figure 2.18 System level mimic display screen

Three meters are included on the mimic display screen to indicate the rectifier, inverter, bypass and load voltage, frequency and current. The displayed battery parameters include the battery temperature and remaining autonomy time. The meter display sources are selected by pressing lightly on the touch-sensitive area on the mimic display.

2.7.3 Module selection screen

The module selection screen is accessed by pressing the MODULE SELECTION icon on the display header bar (item F in Figure 2.17). On opening, the screen displays an icon for every UPS module connected to the system (in all cabinets) and indicates their operating status through the colour-coding shown in Figure 2.19.

The UPS modules, which are identified numerically by the ID number entered into the module's configuration set-up during commissioning, are shown in vertical columns representing each UPS cabinet.

Touching a module icon provides access the status and measurements navigation screen for the selected module.



| | | |
|----------|-------|--------------------------------|
| A | Black | Module in normal operation |
| B | White | Module inactive – switched OFF |
| C | Red | Module has a general alarm |

Figure 2.19 Module selection display screen

Module / System operational status mimic

When a UPS 'module level' screen is accessed it's display is similar to the default 'system-level' screen, except that the mimic display and metering refers specifically to the selected UPS module.

Module / System ON-LINE

This is the normal mimic indications for a (standard) ON-LINE UPS.

1. The rectifier and inverter are working normally.
2. The battery is charging.
3. The bypass line is live and available.

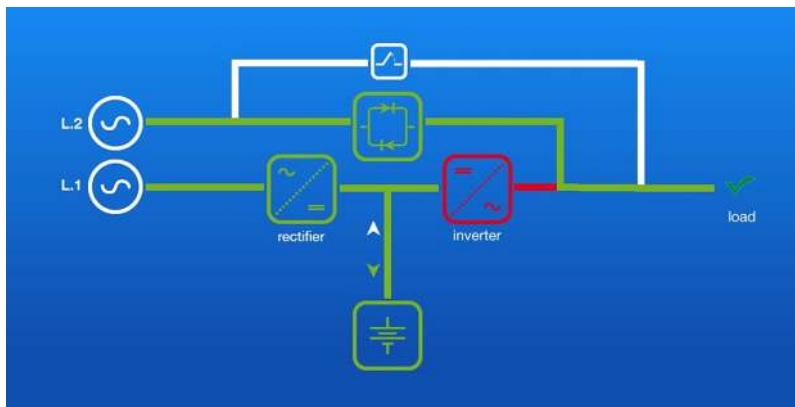
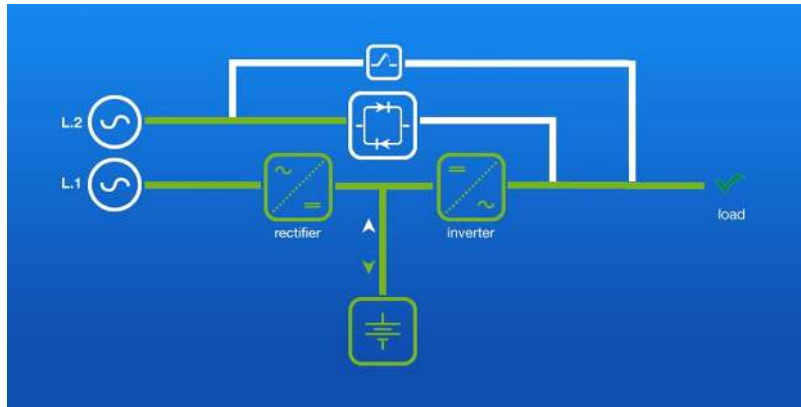

Module / System ON-BYPASS

This is the normal mimic indications if the UPS is operating in ECO mode. In the case of a standard ON-LINE UPS it indicates that either the UPS has a fault/overload which has transferred its output to the bypass, or the number of off-line modules has exceeded the system redundancy.

1. The rectifier is working normally.
2. The battery is charging.
3. The inverter is turned OFF.

Module / System ON MAINTENANCE BYPASS

This mimic indicates that the maintenance bypass isolator is closed and the UPS output is connected to the bypass supply through both the 'maintenance' and 'static' bypass lines in parallel.

1. The rectifier is working normally.
2. The battery is charging.
3. The Inverter is turned OFF.

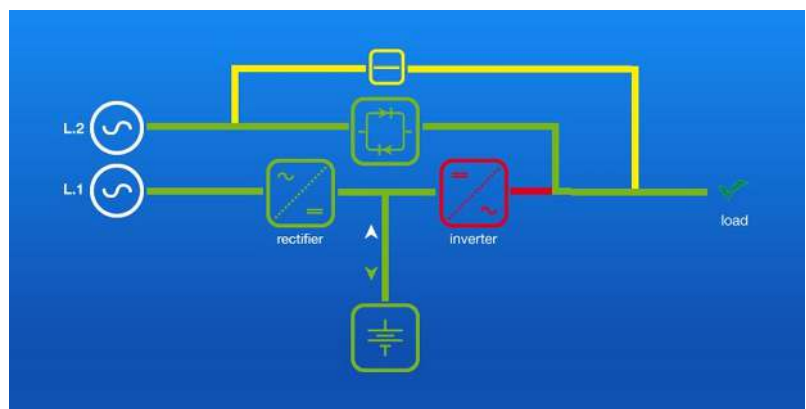

Figure 2.20 Operational status mimic display

2.7.4 Home screen

The home screen, which is accessed by pressing the HOME icon on the display header bar on any screen (item A in Figure 2.17), contains six icons that provide access to various control and set-up function screen.



| | | |
|----------|----------|---|
| A | Events | Displays a list of recently occurred events with date, time, event name, description and sequential ID number. It is possible to order the events and as default the most recent appears on top |
| B | Measures | This item displays the full set of measurements for each functional block of the UPS (detailed below). |
| C | Command | In this menu, the user can change the operating mode of the UPS. Once the command is executed, the user is immediately directed to the mimic diagram where the new status of the UPS is indicated (detailed below). |
| D | Ups Data | Gives information regarding the identity of the UPS module (detailed below). |
| E | User | Enables the adjustment of data such as date and time, automatic battery test, etc (detailed below). |
| F | Service | This password protect facility enables the service technician to adjust several UPS parameters (detailed below). |

Figure 2.21 Home display screen

Measures

| | | | |
|-----------------------------|---------------------------|-----------------------|------------------------------------|
| UPS Measurements | Output Voltage (V) | Output Current (A) | Output Frequency (Hz) |
| | Output Power (%) | Active Power (kW) | Reactive Power (kVA _r) |
| | Apparent Power (kVA) | Inverter Voltage (V) | Bypass Voltage (V) |
| | Bypass Frequency (Hz) | Rectifier Voltage (V) | Booster Temperature (°C) |
| | Inverter Temperature (°C) | Udc Gain + | Udc Gain - |
| Battery Measurements | Temperature (°C) | Discharge Current (A) | Charge Current (A) |
| | Voltage (V) | Run Time | Capacity(%) |

Commands

| | | | |
|---|-------------------|-----------------|--|
| Available commands | *Load to inverter | *Load to bypass | |
| | | | |
| *User password protected (default password = 1234) | | | |

UPS Data

| | | | |
|-----------------|------------------|-----------------|------------------|
| UPS Data | Serial Number | Manufacturing | Firmware Version |
| | Hardware Version | Display Version | |

User

| | | | |
|---------------------|--------------|-------------|---------------------|
| UPS Settings | Language | Date | Time |
| | Battery Test | Repeat Test | Generator Operation |

Service

For the use of trained maintenance personnel only.

2.8 Warranty

The Kohler PW 8000DPA ST UPS is supplied with a limited warranty that the UPS and its component parts are free from defects in materials and workmanship for a period of one year from the date of original commissioning, or fifteen months from the date of original delivery, whichever is the sooner. This warranty is the only warranty given and no other warranty, express or implied, is provided.

This warranty is invalidated if the UPS is used without having first been commissioned by a fully trained and authorised person. This warranty does not apply to any losses or damages caused by misuse, abuse, negligence, neglect, unauthorised repair or modification, incorrect installation, inappropriate environment, accident, act of God or inappropriate application.

If the UPS fails to conform to the above within the warranty period then Kohler Uninterruptible Power will, at its sole option, repair or replace the UPS. All repaired or replaced parts will remain the property of Kohler Uninterruptible Power

As a general policy, Kohler Uninterruptible Power does not recommend the use of any of its products in life support applications where failure or malfunction of the product can be reasonably expected to cause failure of the life support device or to significantly affect its safety or effectiveness. Kohler Uninterruptible Power does not recommend the use of any of its products in direct patient care. Kohler Uninterruptible Power will not knowingly sell its products for use in such applications unless it receives in writing assurances satisfactory to Kohler Uninterruptible Power that the risks of injury or damage have been minimized, the customer assumes all such risks and the liability of Kohler Uninterruptible Power is adequately protected under the circumstances



CAUTION: The UPS system may contain batteries which must be re-charged for a minimum of 24 hours every six months to prevent deep-discharging. Batteries that have been, for whatever reason, deeply-discharged are not covered by the warranty.

2.9 Extended Warranty

The Standard Warranty may be enhanced by protecting the UPS with an Extended Warranty Agreement (maintenance contract). An Extended Warranty Agreement enhances the standard warranty by providing:

- Regular preventative maintenance inspections
- Guaranteed speed of response to operational problems
- 24 hour telephone support
- Fully comprehensive (excluding batteries) cover

Contact the Service Support Hotline on +65 6302 0702 for further details

2.10 Additional Service/Maintenance Support

If you are interested in obtaining an extended warranty for your Kohler PW 8000DPA ST, or require service/maintenance support for any other UPS you may have, please contact Kohler Uninterruptible Power at the following address:

Kohler Uninterruptible Power
 7 Jurong Pier Road
 Singapore
 619159

Tel: +65 6302 0702

Email: serviceups.sg@kohler.com

3 Installation

3.1 Introduction

This chapter contains essential information concerning the unpacking, installation planning and cabling of the Kohler PW 8000DPA ST UPS system.



Key Point: If you are installing an external battery cabinet supplied by Kohler Uninterruptible Power you should refer to the manual that is supplied with the cabinet for installation instructions.



WARNING: All the operations described in this chapter must be supervised by suitably qualified personnel and all aspects of the electrical installation must be carried out by an authorised electrician.

Kohler Uninterruptible Power will take no responsibility for any personal injury or material damage caused by incorrect cabling or operation, or activities which are not carried out in strict accordance with the instructions contained in this manual.



WARNING: Once the UPS equipment is installed it must be commissioned by an engineer approved by Kohler Uninterruptible Power or one of its service agents before it is powered-up. Kohler Uninterruptible Power will take no responsibility for any personal injury or material damage caused by the application of electrical power to this equipment before it has been fully commissioned.

3.2 Taking receipt of the UPS

The UPS and accessories are delivered on a specifically designed pallet that is easy to move with a forklift or a pallet jack.



CAUTION: Observe the following precautions when off-loading and moving the UPS:

- Always keep the packages in an upright position.
- Do not drop the equipment.
- Do not stack the pallets.

Depending on the method of shipping, the UPS is packed in a cardboard or wooden container designed to protect it from mechanical and environmental damage. Further protection is provided by wrapping the equipment with a plastic sheet.

Before you accept the shipment, ensure that the received UPS packages correspond to the description indicated in the delivery document. Note that some ordered optional equipment packages might be shipped inside the UPS cabinet.

When you receive the UPS, carefully examine the packing container for signs of physical damage. The external 'Tip&Tel' ("FRAGILE" and "ARROW") indicators should be intact if the equipment has been transported in an upright position.

3.2.1 Reporting transpiration damage



WARNING: If the Tip&Tel indicators indicate that the UPS has been tilted in transit DO NOT connect the UPS to the mains electricity supply.

If the 'Tip&Tel' indicators are ruptured or there are other signs of suspected transportation damage you must inform the carrier and Kohler Uninterruptible Power immediately.

Other claims for shipping damage must be filed immediately where found, and the carrier must be informed of ALL claims within seven days of receipt of the equipment. If the equipment is to be stored for longer than seven days before it is installed, you should unpack it and inspect it for signs of internal damage before you put in storage. Note that some optional equipment packages might be shipped inside the UPS cabinet and these too should be checked for damage.

If the equipment is damaged you should store the packing materials for further investigation

3.2.2 Local site transportation

When you transport the UPS equipment after it has been off-loaded (for example, for storage or moving to the installation location) please observe the following precautions.



CAUTION: Local transportation:

- When moving the UPS cabinet using a forklift or pallet jack, insert the lifting equipment forks into the front and rear shipping brackets to lift the cabinet securely and prevent it from toppling over.
- Do not at any time tilt the cabinet by more than 10° from vertical.



WARNING: Potential dangers:

- If the equipment cabinet is tilted by more than 10° it could cause internal damage. If tilting occurs do not connect the UPS to the mains electrical supply.
- The weight cabinet can cause serious personal injury and/or structural damage to the surrounding area if dropped in transit. Always take extreme care when moving the equipment.

3.2.3 Storage

If you plan to store the UPS prior to its installation it should be kept in a clean, dry environment with a temperature between -25°C to +70°C and RH <90%, and preferably in its shipping packaging. If the storage period is likely to exceed seven days the packaging should be removed and the UPS inspected for internal/external shipping damage before it is placed into storage. If there is no apparent damage you should refit the packaging or cover the UPS with a dust-cover to prevent the ingress of dust and dirt.

As standard, the UPS batteries can be housed within the UPS cabinet (40kVA and 60kVA models) or within an external battery cabinet or rack-mounted (80kVA, 120KW, 200kVA models). In the case of internally-mounted batteries, the batteries can be shipped already fitted within a cabinet; alternatively, batteries intended for external rack-mounting will be shipped in a separate package. which should be stored under the environmental conditions stipulated above.

3.2.4 Unpacking



WARNING: The UPS system, the battery cabinet (optional) and the batteries are heavy and may tip during transportation causing serious injury if the unpacking instructions are not followed closely.

If the shipment is received in good order (i.e. the 'tip & tell' "FRAGILE" and "ARROW" indicators on the packing container are intact) then unpack the UPS as follows:

1. If the cabinet is shipped inside a wooden case, remove the screws at the base and sides of the case then carefully remove the case from the package.
2. Cut the wrappers and remove the packing container by pulling it upwards.
3. Remove the plastic sheeting covering the UPS.
4. Remove the UPS from the pallet.
5. Retain the packaging materials for future shipment of the UPS.
6. Examine the UPS for any sign of damage and notify your supplier immediately if damage is apparent.
7. Open the cabinet door and verify that the UPS rating specifications on the nameplate located inside the door match the order specification.
8. Remove any accessories packages that are shipped inside the cabinet.
9. Remove any internal protective packaging.
10. Ensure that all the UPS modules are securely fitted in their compartments. Ensure that a protection cover is fitted to the front of any empty UPS compartments.

3.2.5 Batteries



CAUTION: The UPS batteries must ALWAYS be installed by the commissioning engineer.

If the batteries are shipped in a separate package they should remain in their packing until required by the Kohler Uninterruptible Power service engineer when the system is commissioned.

Battery life depends very much on temperature and should ideally be stored and operated at a temperature of 20°C.



WARNING: If the UPS is delivered without batteries, Kohler Uninterruptible Power will not accept responsibility for any damage or malfunctioning caused to the UPS by the incorrect storage, installation or connection of batteries carried out by third parties.

3.3 Positioning

3.3.1 Planning the installation

A certain amount of pre-planning will help ensure smooth, trouble-free equipment installation. The following guidelines should be taken into account when planning a suitable UPS location and operating environment.

1. The equipment must be installed and transported in a upright position.
2. The floor at the installed location and en-route from the off-loading point must be able to safely take the weight of the UPS and battery equipment plus fork lift during transit.
3. The UPS cabinet requires space to bottom/front, top and back to enable cooling airflow, as shown in figures 3.1 and 3.2. The ST200 battery circuit breaker is located on the back of the cabinet and suitable access must be provided to operate the breaker. Two alternative installation layouts are shown in Figure 3.2.
4. A minimum clearance of 200mm must be provided at the back of the cabinet to provide adequate ventilation. A clearance of 400mm should also be provided at the top of the cabinet if there is insufficient route at the back of the cabinet to dissipate the cooling airflow.
5. All parts of the UPS required for maintenance, servicing and user operation are accessible from the front. Reserve a minimum of 1000mm space at the front of the UPS cabinet. Note also that the cabinet right-hand door must be opened by 115° in order to remove/fit the UPS power modules so the right-hand side of the cabinet cannot be positioned directly against a projecting wall.
6. An ambient UPS temperature of 20°C is necessary to achieve the recommended life span. The cooling air entering the UPS must not exceed +40°C.
7. Avoid high ambient temperature, moisture and humidity. The floor material should be non-flammable and strong enough to support the heavy load.
8. In summary, the UPS should be located where:
 - a) Humidity (< 90%) and temperature is ideally 20°C.
 - b) Fire protection standards are respected.
 - c) Cabling can be performed easily.
 - d) A minimum 1000mm front accessibility is available for service or periodic maintenance.
 - e) Adequate cooling air flow is available.
 - f) The air conditioning system can provide a sufficient amount of air cooling to keep the room at, or below, the maximum desired temperature.
 - g) No dust or corrosive/explosive gases are present.
 - h) The location is vibration free.
 - i) If the UPS will be installed in bayed enclosures, partition walls have to be installed.

3.3.2 Clearances

Figures 3.1 and 3.2 illustrates the required clearances that must be provided around the UPS and external battery cabinet. All parts of the UPS that require access for maintenance, servicing and user operation are accessible from the front of the cabinet. Ensure that all ventilation ports are kept free of obstruction.

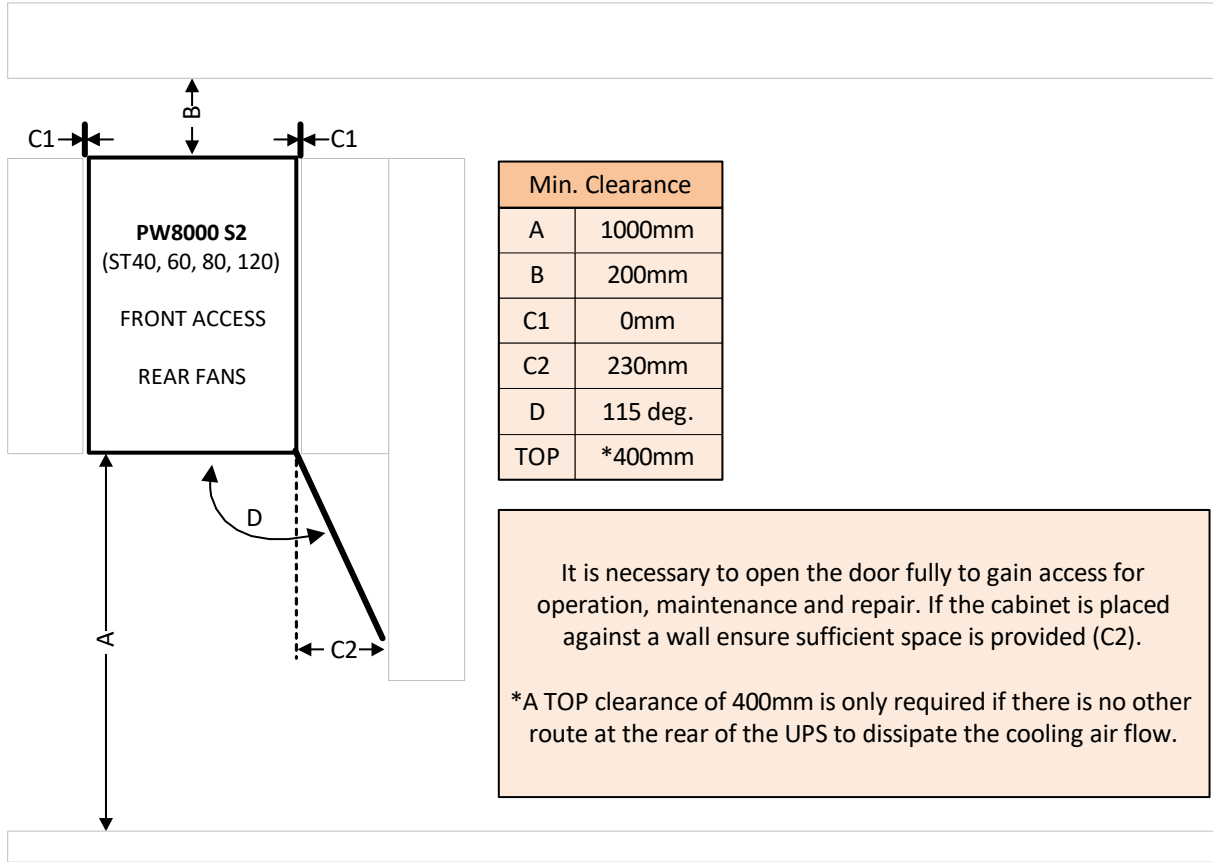

| | ST-40 | ST-60 | ST-80 | ST-120 | ST-200 |
|----------------------------|---|------------------|------------------|------------------|------------------|
| Dimensions (WxHxD) mm | 550 x 1135 x 770 | 550 x 1975 x 770 | 550 x 1135 x 770 | 550 x 1975 x 770 | 550 x 1975 x 770 |
| Maintenance Accessibility | *Totally front accessibility for service and maintenance (no side, top or rear access required) | | | | |
| Input/Output Power Cabling | From the bottom | | | | |

***Note:** The battery fuses are located on the back of the ST-200 cabinet and rear access is required to operate the equipment. See Figure 3.2 for optional installation positioning of the ST200 cabinet.

Figure 3.1 ST40-ST120 Clearance recommendations

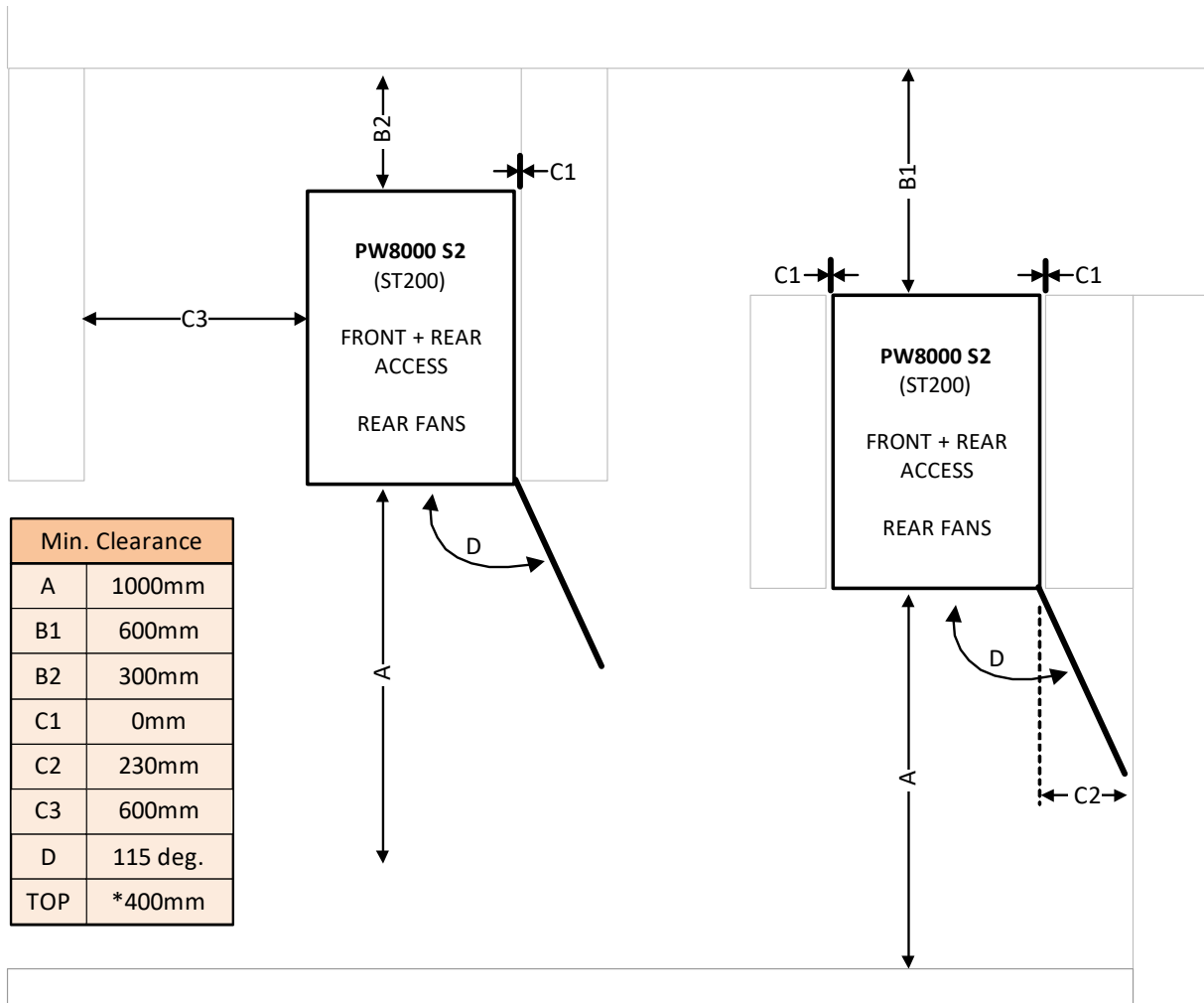

It is necessary to fully open the cabinet door to gain access for operation, maintenance and repair. This requires a minimum front clearance of 1000 mm and if the cabinet is placed against a wall a sufficient side clearance must be provided to allow the door to open through a 115° arc (C2).

Rear access is required to operate the ST200 battery fuses.

If there is free passage behind the cabinet a minimum rear clearance of 600mm is required in order to safely access the fuses (B1). Alternatively, a side clearance of 600mm (C3) and rear clearance of 300mm (B2) should be provided.

*A TOP clearance of 400mm is only required if there is no other route at the rear of the UPS to dissipate the cooling airflow.

Figure 3.2 ST200 Clearance recommendations

3.4 UPS Power Cabling (preparation and planning)

3.4.1 General requirements

It is the customer’s responsibility to design the UPS supply and distribution circuits, and provide all the external fuses, isolators and cables required to connect the UPS input and output power supplies and battery cabinet. The information in this section should assist in the planning and preparation of the UPS power cabling.

The UPS rectifier supply and bypass supply should be connected to the utility mains through a LV-switchgear panel and protected by a circuit breaker or fuse to provide overload protection and a means of isolating the UPS from the mains supply. Similarly, the UPS output should be connected to the load equipment via a suitably fused switchgear panel.

The UPS can be wired with a ‘single feed’ input (standard) or with a ‘dual feed’ input, whereby the UPS bypass circuit is connected to a dedicated mains ‘bypass’ supply (see Figure 3.3).

3.4.2 Cable sizing



Key Point: This information is given for guidance only. All fuses, isolators and power cables must be rated and installed in accordance with the prescribed IEC standards or local regulations – e.g. BS7671.

The table below shows the maximum UPS input and output current together with the UPS cable termination details. This is provided to assist the customer in selecting the appropriate power cables and external switchgear. Details of the UPS power connections are shown in Figure 3.5 and Figure 3.6.

| | 400V / 230V | | | | | | BATTERY | | |
|---------------|-----------------------------|---|---------------------------|-----------------------------|------------|---|-----------------------------|-----------------------------|---------------------------------|
| | UPS INPUT MAINS (Rectifier) | | UPS BYPASS MAINS (Bypass) | | UPS OUTPUT | | PE | Separate | Common |
| | Max. Amps | Terminal (mm ²) | Max. Amps | Terminal (mm ²) | Max. Amps | Terminal (mm ²) | Terminal (mm ²) | Terminal (mm ²) | Terminal (mm ²) |
| ST-40 | 68 | 3x 25 (T) 1x 25 (N)(T) 1x 25 (PE)(T) | 68 | 3x 25 (T) 1x 25 (N)(T) | 58 | 3x 25 (T) 1x 25 (N)(T) 1x 25 (PE)(T) | | | |
| ST-60 | 102 | 3x 35 (T) 1x 35 (N)(T) 1x 50 (PE)(T) | 102 | 3x 35 (T) 1x 35 (N)(T) | 87 | 3x 35 (T) 1x 35 (N)(T) 1x 50 (PE)(T) | | | |
| ST-80 | 136 | 3x 50 (T) 1x 50 (N)(T) 1x 50 (PE)(T) | 136 | 3x 50 (T) 1x 50 (N)(T) | 116 | 3x 50 (T) 1x 50 (N)(T) 1x 50 (PE)(T) | 1x 50 (T) | 3x (4x16) (T) | 3x M6 (B) |
| ST-120 | 208 | 3x 95 (T) 1x 95 (N)(T) 1x M10 (PE)(B) | 208 | 3x 95 (T) 1x 95 (N)(T) | 174 | 3x 95 (T) 1x 95 (N)(T) 1x M10 (PE)(B) | 1x M10 (B) | 3x (6x 16) (T) | 3x (2x M5) (B) or 3x M10 (B) |
| ST-200 | 333 | 3x M12 (B) 1x M12 (N)(B) 1x M12 (PE)(B) | 333 | 3x M12 (B) 1x M12 (N)(B) | 290 | 3x M12 (B) 1x M12 (N)(B) 1x M12 (PE)(B) | 1x M10 (B) | 3x (5x35) (T)* | 3x (2xM10) (B) |

(PE) = Protective Earth
 (N) = Neutral
 (B) = Busbar connections with indicated bolt size. Cable must be terminated with a suitable lug.
 (T) = Screwed terminal block with indicated maximum cable c.s.a. Cables must be suitably prepared.
 * In the ST-200 model with individual battery configuration, each battery feeds two UPS modules.

Notes:

1. The UPS must be installed to prescribed IEC or local regulations (e.g. BS7671).
2. Where external batteries are used, DC Cables and Battery fuses are bespoke to the installation.

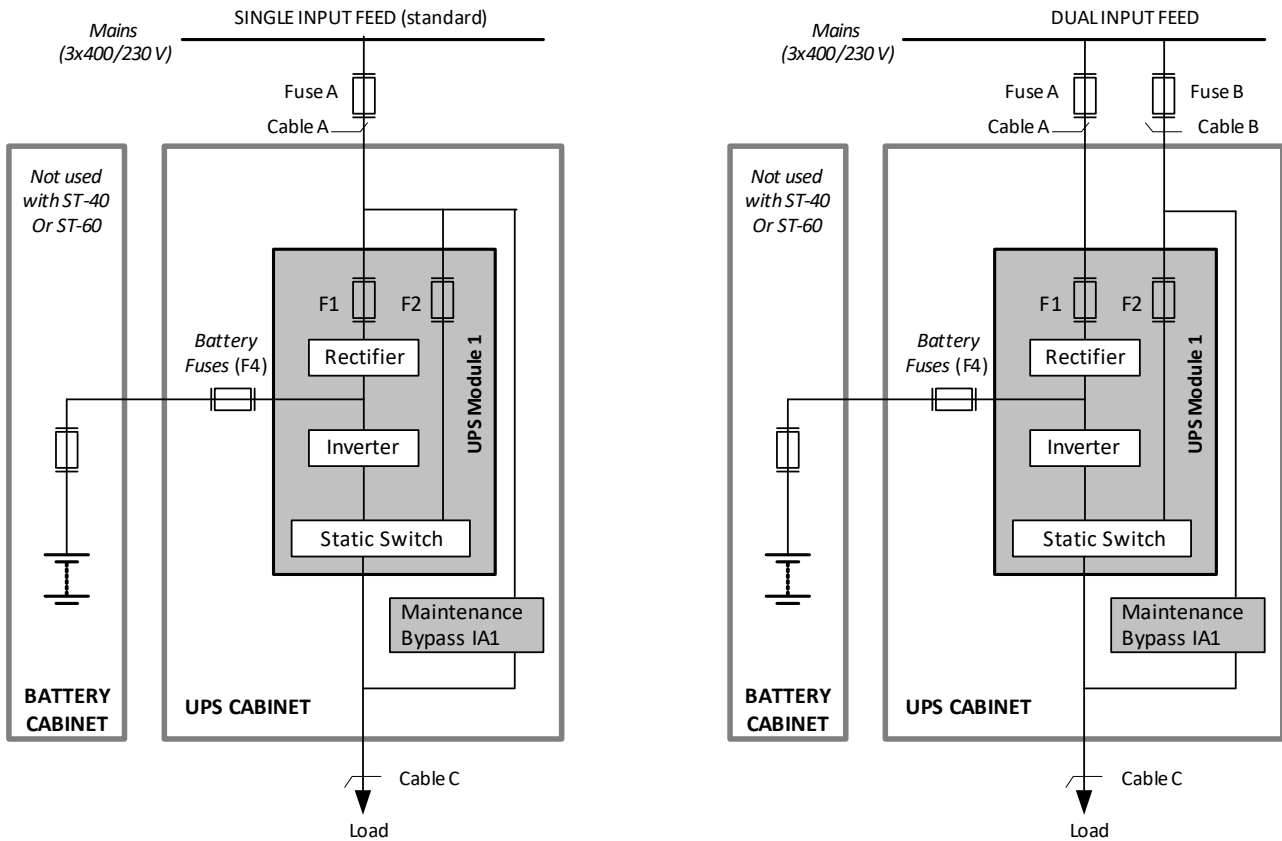

Figure 3.3 PowerWAVE 8000DPA ST single input and dual input supply

Input neutral grounding



Key Point: An input neutral is required to operate the rectifier. In TN-S systems, the input neutral must be permanently connected. During battery operation the neutral must always be grounded.

DO NOT SWITCH THE INPUT NEUTRAL. Connect the rectifier input mains supply using a 3-pole breaker only

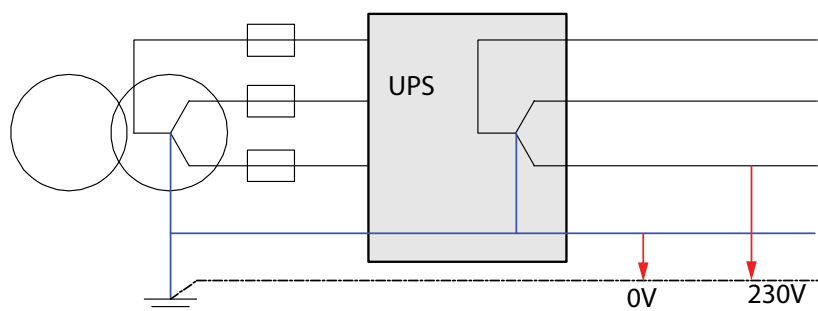
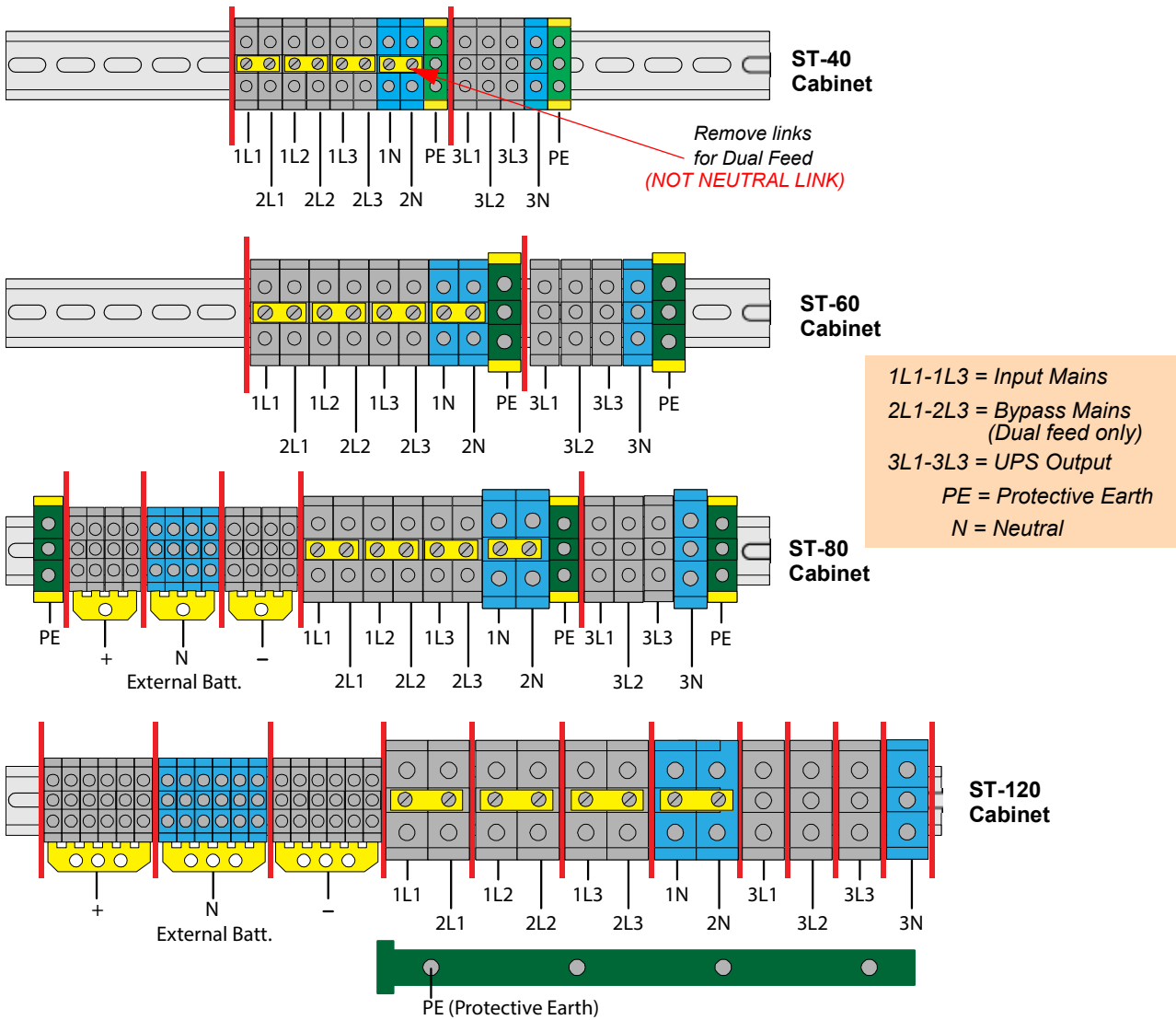

Figure 3.4 Input neutral grounding



| UPS Range | Separate Battery (+ / N / -) | Common Battery (+ / N / -) | Bypass Mains (3+N) | Input Mains (3+N+PE) | UPS Output (3+N+PE) |
|-----------|---|---|----------------------------|---|---------------------|
| ST-40 | | | 4 x 25 mm ² (T) | 5 x 25 mm ² (T) | |
| ST-60 | | | 4 x 35 mm ² (T) | 4 x 35 mm ² (T) PE 50 mm ² (T) | |
| ST-80 | 3 x (4 x 16 mm ²) (T) PE 1x 50 mm ² (T) | 3 x M6 (B) PE 1x 50 mm ² (T) | 4 x 50 mm ² (T) | 5 x 50 mm ² (T) | |
| ST-120 | 3 x (6 x 16 mm ²) (T) PE 1x M10 (B) | 3x (2 x M5) (B) or 3x M10 (B) PE 1x M10 (B) | 4 x 95 mm ² (T) | 4 x 95 mm ² (T) + PE M10 (B) | |

Notes:

1. Fuse and Cable recommendations to IEC 60950-1:2001.
2. The fuse and cable rating details in the above tables are a recommendation only.
3. The UPS must be installed to prescribed IEC or local regulations (e.g. BS7671).
4. DC Cables and Battery fuses are bespoke to the installation.

Figure 3.5 ST-40, ST-60, ST-80, ST-120 Maximum cable connection sizes

1L1-1L3 = Input Mains
2L1-2L3 = Bypass Mains (Dual feed only)
3L1-3L3 = UPS Output
PE = Protective Earth
N = Neutral

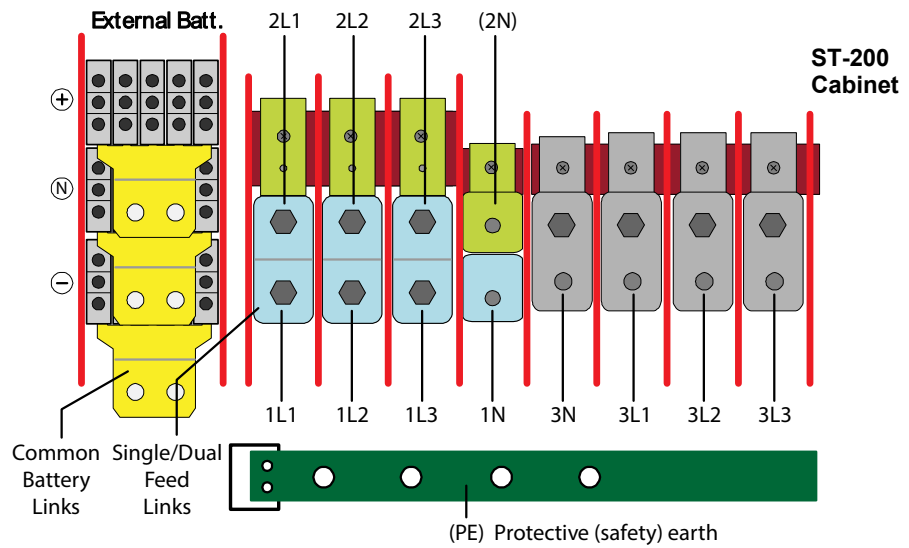

Remove links for separate battery installation and connect batteries to individual terminals.
Note that when using individual batteries, each battery is connected to two UPS modules.

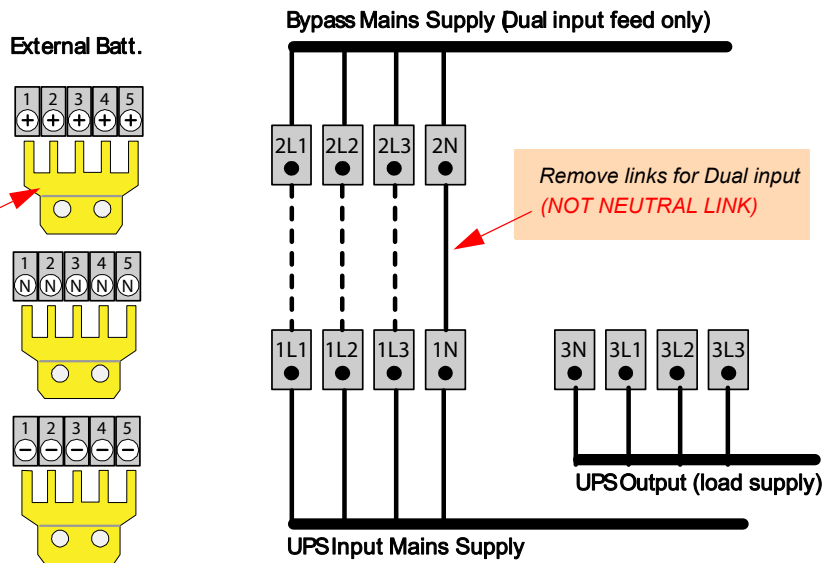

| UPS Range | Separate Battery | Common Battery (+ / N / -) | Bypass Mains (3+N) | Input Mains (3+N+PE) | UPS Output (3+N+PE) |
|-----------|--|--------------------------------------|--------------------|----------------------|---------------------|
| ST-200 | 3x (5 x 35 mm ²)(T) (1 Batt feeds 2 modules) +PE 1 x M10 (B) | 3 x (2 x M10) (B) +PE 1 x M10 (B) | 4 x M12 (B) | 5 x M12 (B) | 5 x M12 (B) |

Notes:

1. Fuse and Cable recommendations to IEC 60950-1:2001.
2. The fuse and cable rating details in the above tables are a recommendation only.
3. The UPS must be installed to prescribed IEC or local regulations (e.g. BS7671).
4. DC Cables and Battery fuses are bespoke to the installation.

Figure 3.6 ST-200 Maximum cable connection sizes

3.4.3 Parallel cabinet cabling recommendations

In order to achieve equal load sharing between the various UPS cabinets in a multi-cabinet installation, the input cables from the mains switchgear panel to each UPS cabinet should be of equal length. Similarly the UPS output cables to the switchgear panel should be of approximate equal length.

CORRECT

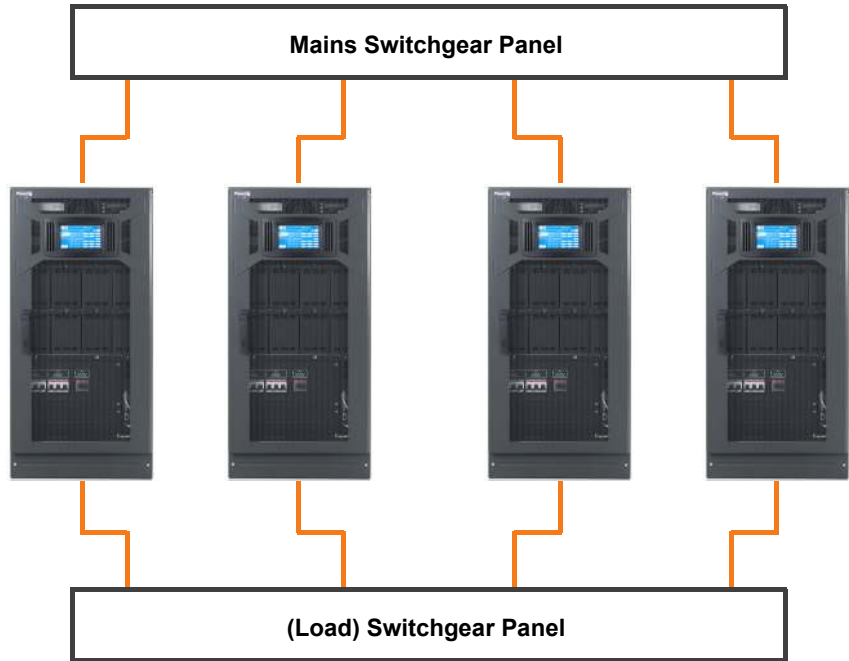

INCORRECT

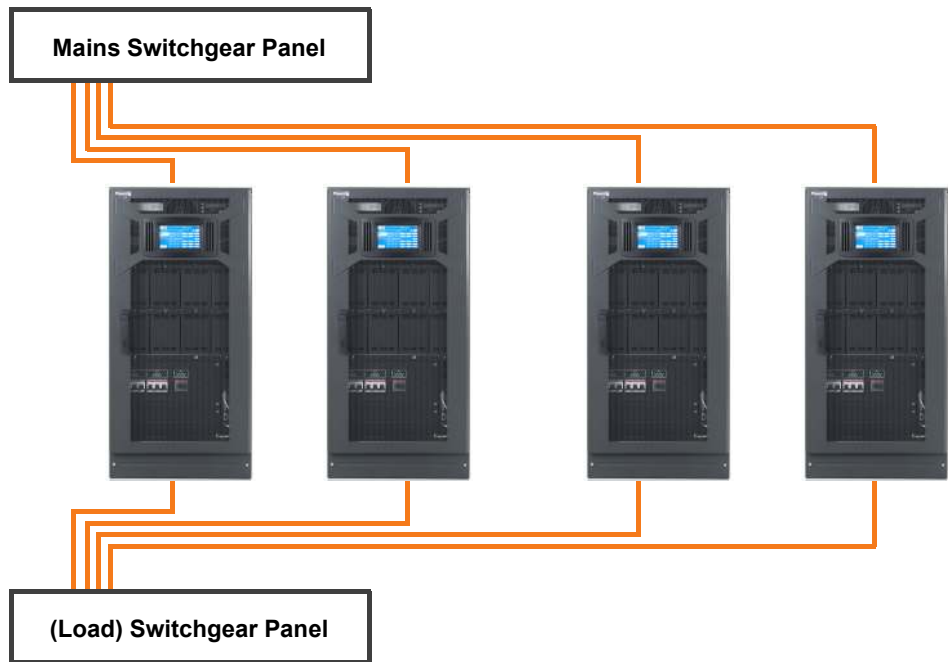

Figure 3.7 Parallel cabinet cabling considerations

3.4.4 External maintenance bypass

An external maintenance bypass is a required part of a multi-cabinet system but is optional in the case of a single cabinet installation.

The external bypass is bespoke to the installation but generally comprises three isolators rated to carry the full system load and connected in a similar fashion to that shown in Figure 3.8. Depending on size and location, the isolators may be installed in a dedicated Maintenance Bypass cabinet or included in an existing (or dedicated) switchgear panel.

Kohler Uninterruptible Power can provide a range of external maintenance bypass solutions to suit all of its UPS systems.

Note: When starting the UPS system we advise that the load is initially turned on while the system is operating on maintenance bypass in order to handle any large inrush currents that might occur.

Single UPS cabinet installation

An external maintenance bypass facility is not essential for a single cabinet installation as the internal maintenance bypass switch (IA1) is fully rated and can be used to connect the load directly to the raw UPS bypass mains supply. However, when operating via the internal maintenance bypass switch (IA1) the UPS input/bypass mains supply must be permanently available, so it is not possible to isolate these supplies from the cabinet (or UPS modules) while the internal maintenance bypass is in use.

This situation is overcome by the addition of an external maintenance bypass circuit, similar to that shown in Figure 3.8, which can supply the load through the external BYPASS switch while allowing the UPS cabinet input and output to be totally isolated by opening the external INPUT and OUTPUT switches.

Parallel UPS cabinet installation

If two (or more) UPS cabinets are connected as a parallel system each one still contains the internal maintenance bypass switch (IA1). However, the switch is only rated for the specified cabinet output and is not designed to switch the potential full system load.

An external maintenance bypass facility containing a 'system rated' bypass switch is therefore an essential part of a parallel cabinet system as it allows the full load to be switched between the system and maintenance bypass. It also allows the modules' input and bypass mains supplies to be isolated as described above for the single UPS cabinet system.

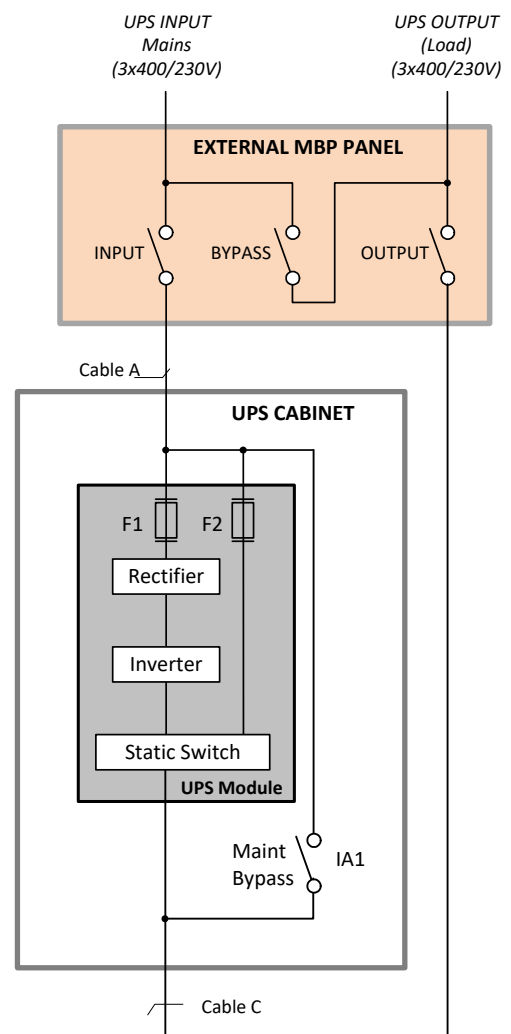

Figure 3.8 External Maintenance Bypass



Key Point: When operating a parallel system ALWAYS use the external maintenance bypass facility. Do not operate the internal maintenance bypass switch (IA1).

3.5 Connecting the UPS AC power cables



WARNING: Opening or removing the UPS enclosure covers will create a risk of exposure to dangerous voltages if power is connected to the UPS.



WARNING: DC cabling for the battery system(s) must be completed by a Kohler Uninterruptible Power engineer or one of its approved service agents.

3.5.1 Safety notes

Please ensure you read and understand the following safety notes before you begin the UPS electrical installation.

1. All the operations detailed in this section must be performed by an authorised electrician or qualified personnel.
2. Once the electrical installation is completed the initial UPS start-up must be performed by qualified commissioning engineer authorised by the manufacturer.
3. Do not operate the UPS if there is water or moisture present.
4. When working on the UPS input power cables, you must ensure that the UPS mains supply is isolated at the supply LV-switchgear panel and, where possible, locked out. Warning notices should be posted where applicable to prevent the inadvertent operation of the LV supply isolator(s).
5. For personal protection, ensure the following conditions are met prior to starting work on the equipment:
 - a) No mains voltage is present from the mains switchgear panel.
 - b) All loads are shut down and disconnected.
 - c) The UPS is shut down and voltage-free, with all internal power isolators OPEN (OFF).

3.5.2 Preparing the UPS power cabling

Before you connect the UPS input cables:

1. Ensure that the provided fuses and cables are in accordance with the prescribed IEC Standards or local regulations (e.g. BS7671).
2. Do not commence this procedure until the UPS is properly mechanically installed at its intended final location.

3.5.3 Connecting the UPS input power cables

1. Gain internal access to the UPS and remove the UPS power terminal block cover.
2. Connect the earth cable from the LV-switchgear panel to the protective earth (PE) terminal in the UPS.

Single Input Feed

Refer to the schematic drawing and connection table in Figure 3.9.

1. Connect the UPS rectifier supply cables to terminals 1L1, 1L2, 1L3 and 1N on the UPS main terminal block – see Figures 3.5 and 3.6. Ensure correct (clockwise) phase rotation.



CAUTION: The input Neutral cable must be permanently connected. Check that it is not being switched through the supply isolator

2. Secure the cables to the fixing rail located under the UPS power terminals.

Dual Input Feed

Refer to the schematic drawing and connection table in Figure 3.9.

1. Remove the links between 1L1 - 2L1; 1L2 - 2L2; and 1L3 - 2L3 on the Input Terminal Block – see Figures 3.5 and 3.6. Leave the Neutral link connected between 1N - 2N.

2. Connect the UPS rectifier supply cables to terminals 1L1, 1L2, 1L3 and 1N on the UPS terminal block, ensuring correct (clockwise) phase rotation.



CAUTION: The input Neutral cable must ALWAYS be connected.

3. Connect the UPS bypass supply cables to terminals 2L1, 2L2, 2L3 and 2N on the UPS terminal block, ensuring correct (clockwise) phase rotation.



CAUTION: If the rectifier and bypass inputs are fed from the same three-phase power source there is no need to connect a separate bypass neutral if the two neutral input terminals are linked at the UPS input connections. If the bypass supply is derived from a different three-phase power source then the bypass neutral must be permanently connected and unswitched.

4. Secure the cables to the fixing rail located under the UPS power terminals.

Note: The UPS commissioning engineer will configure the UPS control system for a dual input operation at the time of commissioning.

3.5.4 Preparing the output power cabling

Before you connect the UPS output cables:

1. Ensure that the potential full load does not exceed the output power rating (OUTPUT POWER) on the UPS nameplate.
2. Ensure the output circuit breakers are correctly sized with respect to the load rating and associated cabling.
3. Check that the output load circuit breakers comply with the prescribed IEC Standards (e.g. BS7671) or local regulations.

It is recommended that a separate switchgear panel is provided for the load and that the maximum total load rating and the load rating of the individual load sockets are indicated on the panel.

3.5.5 Connecting the UPS output cables

1. Connect the protective earth cable from the output (load) switchgear panel to the UPS output protective earth (PE) terminal, as shown in Figure 3.9.
2. Connect the UPS output supply cables to terminals 3L1, 3L2, 3L3 and 3N on the UPS main terminal block. Ensure correct (clockwise) phase rotation.
3. Secure the cables to the fixing rail located under the UPS power terminals.
4. Ensure the output cables are connected to the correct power terminals on the output (load) switchgear panel.



WARNING: Do not close the UPS external power circuit breakers. Once the electrical installation is completed the initial UPS start-up must be performed by qualified commissioning engineer authorised by the manufacturer.

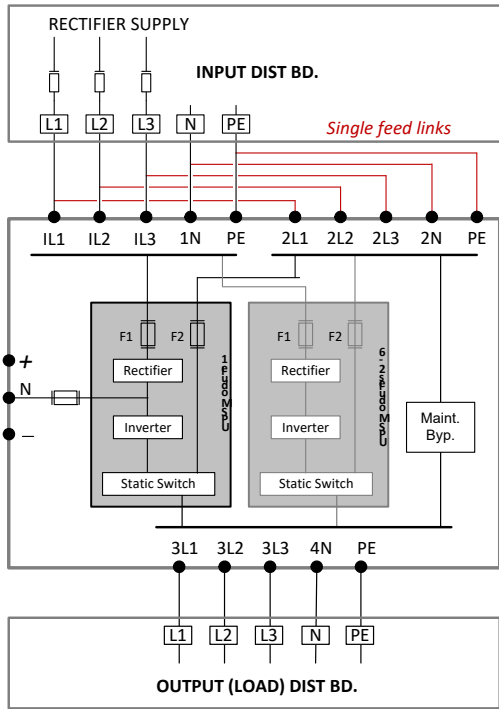

| INPUT CABLE | UPS (Rectifier) TERMINAL |
|-------------|--------------------------|
| Phase L1 | 1L1 |
| Phase L2 | 1L2 |
| Phase L3 | 1L3 |
| NEUTRAL | 1N |
| EARTH | PE |

| OUTPUT CABLE | UPS TERMINAL |
|--------------|--------------|
| Phase L1 | 3L1 |
| Phase L2 | 3L2 |
| Phase L3 | 3L3 |
| NEUTRAL | 3N |
| EARTH | PE |

| INPUT CABLE | UPS (Rectifier) TERMINAL | UPS (Bypass) TERMINAL |
|-------------|--------------------------|-----------------------|
| Phase L1 | 1L1 | 2L1 |
| Phase L2 | 1L2 | 2L2 |
| Phase L3 | 1L3 | 2L3 |
| NEUTRAL | 1N | 2N |
| EARTH | PE | PE |

| OUTPUT CABLE | UPS TERMINAL |
|--------------|--------------|
| Phase L1 | 3L1 |
| Phase L2 | 3L2 |
| Phase L3 | 3L3 |
| NEUTRAL | 3N |
| EARTH | PE |

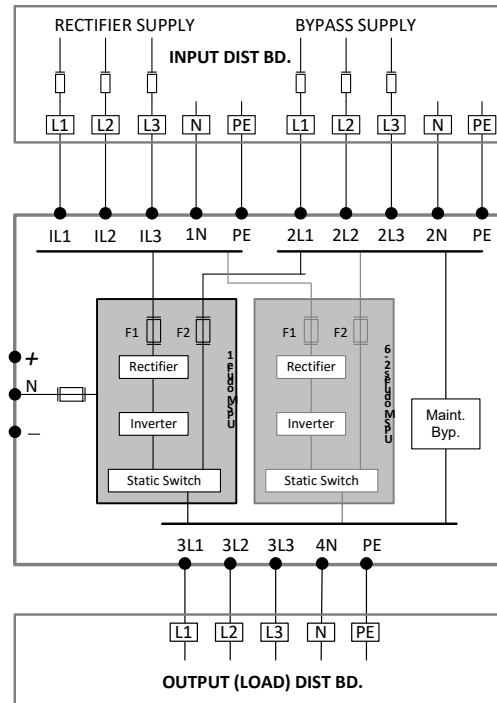

Figure 3.9 Connection diagram for single input feed and dual input feed

3.6 Battery configuration

IMPORTANT NOTE

High voltage battery strings can be extremely dangerous and should not be installed by the customer's installation team. The batteries must be installed and connected to the UPS by an Kohler Uninterruptible Power service engineer.

It is the customer's responsibility to provide appropriate containment for the DC power cables between the UPS cabinet and battery cabinet where necessary – e.g. cable trays or trunking. The battery cabling details shown below are provided for reference only.

3.6.1 Battery configuration options

When considering the Kohler PW 8000DPA ST battery installation, several battery configurations are possible to meet the required load power and battery autonomy time. These factors are determined by:

- The number of battery blocks connected to the battery string, and the number of connected strings
- The battery block capacity (A/hr)
- The method of connecting the battery to the UPS power modules – i.e. either 'Common' or 'Individual' battery.

See the examples shown in the following diagrams.

3.6.2 Battery cabling

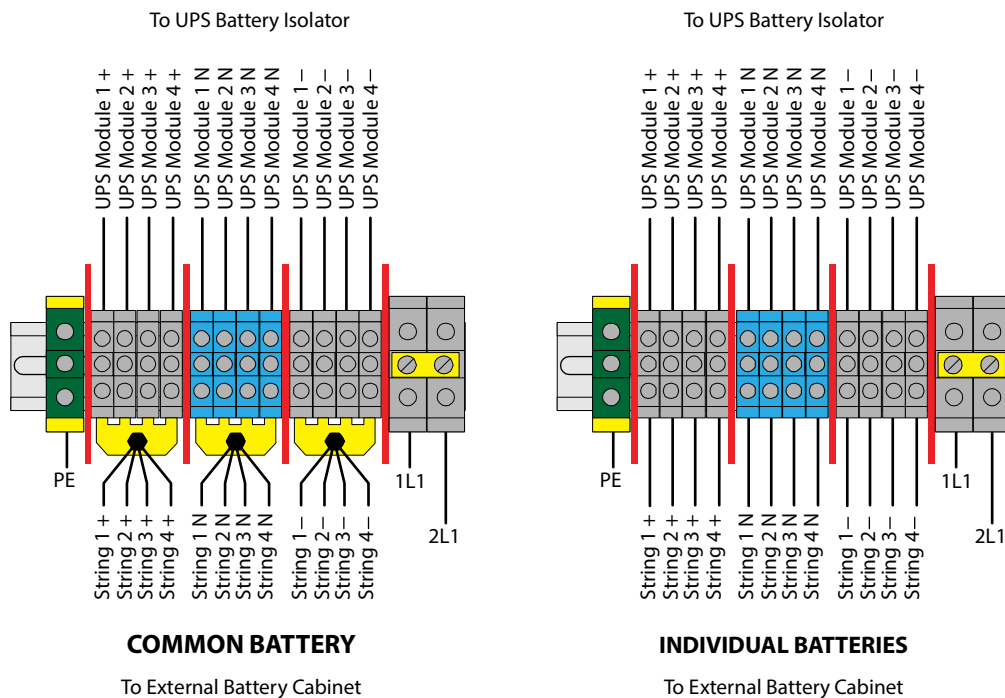

Figure 3.10 Battery connections (ST-80 cabinet shown)

In the ST-80, ST-120 and ST-200 models the external batteries are connected to terminal blocks mounted on the left hand side of the power connection rail. The cables at the top of the terminal blocks are connected to the battery isolators associated with each individual UPS power module and the cables at the bottom of the terminal blocks are connected to the external battery cabinet(s).

The example in Figure 3.10 illustrates the ST-80 cabinet which has four terminal block connections, one for each UPS power module. Each battery string is shown to have three connections annotated '+', 'N' and '-'. The 'N' connection is effectively taken to the centre of the battery string.

Note: In the case of the ST-200 each external battery is connected to two UPS power modules so only five sets of battery connections are provided to cater for the (up to) ten modules. However each UPS power module has an individual battery isolator located on the back of the UPS Cabinet.

Common battery configuration

Where a 'common battery' configuration is implemented, all the UPS modules are fed by a common battery source – which may comprise a number of parallel battery strings. Where this type of installation is used the 'common battery' links must fitted to the battery connection terminal blocks as shown in the left-hand diagram of Figure 3.10. These links must be removed for 'individual battery' configuration.

3.6.3 Internal battery configuration for ST-40 and ST-60 cabinets

The ST-40 and ST-60 cabinets are designed to house 80 and 240 internal 12V (7/9Ah) battery blocks respectively.

Different battery configurations are shown below.

For details of the battery connections see Figure 3.5 and Figure 3.10.

Important notes:

- When the cabinets are populated with 10KW UPS modules the 12V batteries can be connected in strings of 30-50 (even numbers only), depending the power sourced on the output.
- When the cabinets are populated with 20KW UPS modules the 12V batteries can be connected in strings of 40-50 (even numbers only), depending the power sourced on the output.
- The commissioning engineer will program the correct number of battery blocks into the UPS control system using the control panel Service-Set-Up menu when the system is commissioned.

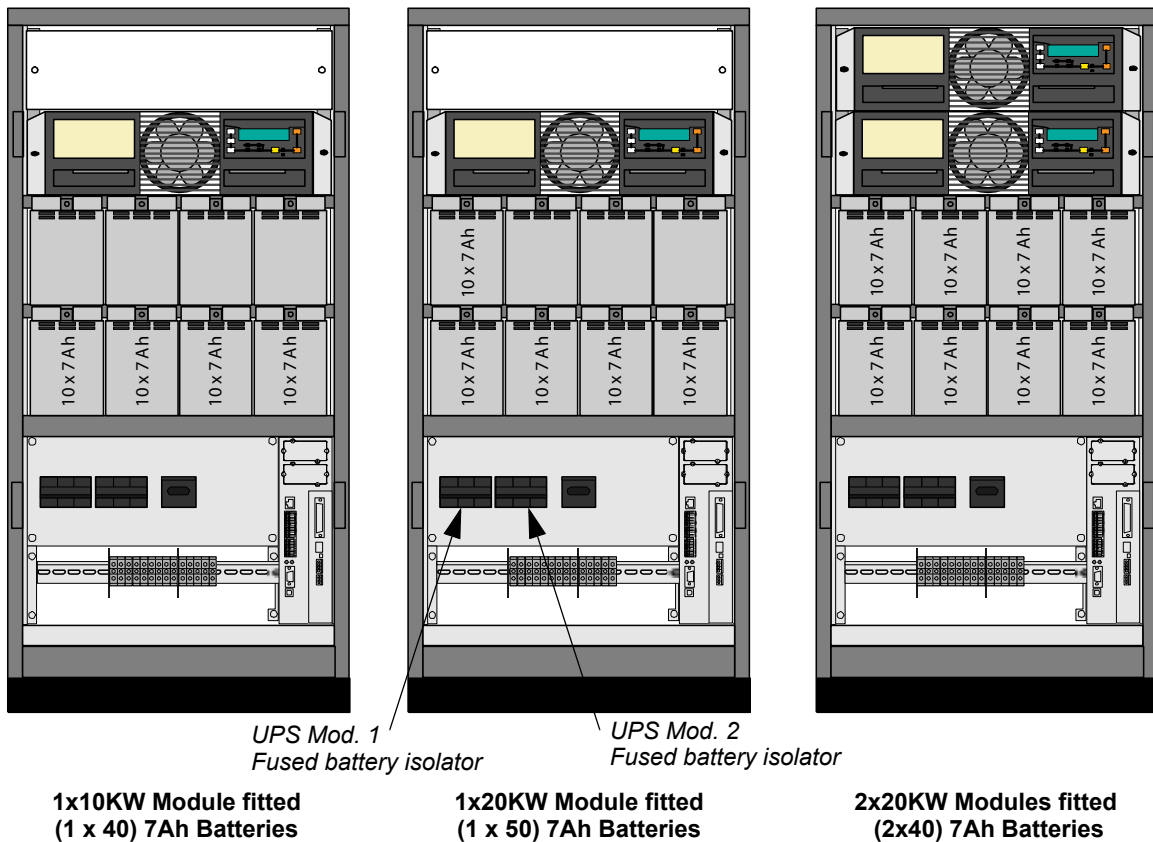
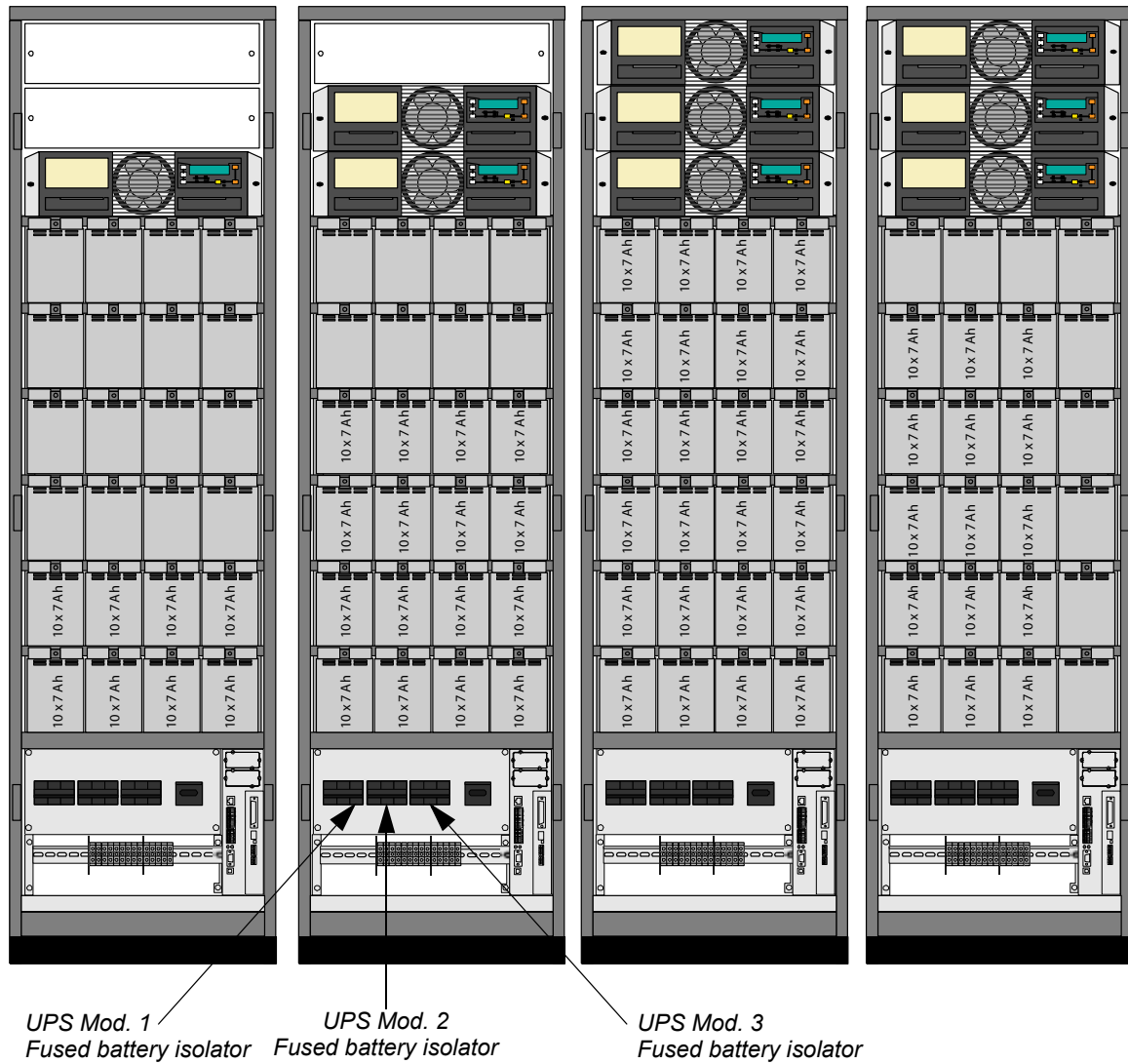

Figure 3.11 ST-40 Cabinet internal battery configuration



**1x10KW Module fitted
1x(2 x 40) 7Ah Batteries**

**2 x 20KW Module fitted
2x(2 x 40) 7Ah Batteries**

**3 x 20KW Module fitted
3x(2 x 40) 7Ah Batteries**

**3 x 20KW Module fitted
3x(1 x 50) 7Ah Batteries**

Figure 3.12 ST-60 Cabinet internal battery configuration

3.7 Customer Interface Board



CAUTION: The Customer Interface Board contain several DIP switches and jumper links which must be configured by the commissioning engineer. Once set, DO NOT touch.

The Customer Interface Board is described in the General Description chapter, section 2.4, with some of its common applications described in detail in the Options chapter. This section deals with the connection of the dry port interface connections taken to terminal blocks X1 and X2 which may be connected at this stage of the installation procedure.

All the on-board relays connected to these terminal blocks are rated at 60VAC / 8A and the Phoenix terminals are rated to take cable of 0.5 mm².

Input interfaces connected to terminal block X1



Key Point: When the UPS cabinet is installed as part of a parallel system the Customer Interface Board I/O is disabled in the 'slave' cabinets if the system 'Multidrop' application is enabled. Under such circumstances the required interface connections should be made to the board fitted in the 'master' module only – see section 2.4.

Note that the connection are described in detail in Chapter 7.

| Terminal | Contact | Signal | Function |
|----------|---------|---------|---|
| X1/1 | IN ← ○ | +12Vdc | Customer IN 1 (default as ONGENERATOR operation) (NC = Generator ON) |
| X1/2 | GND ● ○ | Gnd | |
| X1/3 | IN ← ○ | +12Vdc | Customer IN 2 (Function on request, to be defined on purchase) |
| X1/4 | GND ● ○ | Gnd | |
| X1/5 | IN ← ○ | +3.3Vdc | Battery Temperature If connected, the battery charger voltage is temperature dependent |
| X1/6 | GND ● ○ | Gnd | |
| X1/7 | IN ← ○ | +12Vdc | Remote shut down |
| X1/8 | GND ● ○ | Gnd | |
| X1/9 | OUT ○ → | +12Vdc | 12Vdc source Max 200mA load |
| X1/10 | GND ● ○ | Gnd | |

Note: Terminal block X1 is not used in the slave cabinet(s) of a parallel-cabinet system if 'Multidrop' is used.

Output interfaces connected to terminal block X2



Key Point: When the UPS cabinet is installed as part of a parallel system the Customer Interface Board I/O is disabled in the 'slave' cabinets if the system 'Multidrop' application is enabled. Under such circumstances the required interface connections should be made to the board fitted in the 'master' module only – see section 2.4.

All volt-free contacts are rated 60 VAC max. and 8A max.:

| Pin | Contact | Signal | Function |
|-------|---------|---------------|-----------------------------|
| X2/1 | | MAINS_OK | Mains Present |
| X2/2 | | | Mains Failure |
| X2/3 | | | Common |
| X2/4 | | LOAD_ON_INV | Load On Inverter |
| X2/5 | | | (Load not on inverter) |
| X2/6 | | | Common |
| X2/7 | | BATT_LOW | Battery Low |
| X2/8 | | | Battery OK |
| X2/9 | | | Common |
| X2/10 | | LOAD_ON_MAINS | Load On Static bypass |
| X2/11 | | | (Load not on static bypass) |
| X2/12 | | | Common |
| X2/13 | | COMMON_ALARM | Common Alarm |
| X2/14 | | | No Alarm Condition |
| X2/15 | | | Common |

Note: Terminal block X2 is not used in the slave cabinet(s) of a parallel-cabinet system if 'Multidrop' is used.

3.8 Parallel-cabinet control and configuration



Key Point: The Parallel Interface Board is only fitted to the cabinet if it is used as part of parallel cabinet system.

When several UPS cabinets are connected as a parallel system the modules' electronic control system communicate with each other by means of a parallel control bus which is connected between each cabinet and facilitates various system control functions such as load sharing, frequency synchronisation, and synchronised load transfer (see section 2.4.2). The parallel control bus comprises a 25-way cable which is connected to an adapter board which is fitted to the Parallel Interface Board.

Note: The inter-cabinet Multidrop data connection is also incorporated in the 25-way parallel control bus cable.

The parallel adapter boards and cables are shipped as a 'paralleling kit' and must be fitted by the Kohler Uninterruptible Power commissioning engineer

Once the parallel bus cables are fitted, each cabinet is configured by means of a DIP switch to define its position in the parallel system – one UPS cabinet is configured to act as a 'master' with the remaining cabinets acting as 'slaves.' If the 'master' goes faulty the next cabinet (former 'slave') will immediately take over the roll of the 'master' unit and the former 'master' will switch off.



CAUTION: All parallel control cabling and configuration must be completed by the commissioning engineer.

The Parallel Interface Board is described in section 2.4. This section deals with the optional connections taken to terminal blocks X1 and X2 which may be connected at this stage of the installation procedure.

| Terminal | Contact | Signal | Function |
|----------|---------|--------|---|
| X1/L1 | IN ← ○ | L1 | 'Synchronisation Feature' Option (Line connection) |
| X1 | | | |
| X1/N | GND ● ○ | N | |
| X2/4 | GND ● ○ | Gnd | External Output Isolator (IA1) Option (Min. contact load 12V/20mA) When external output isolator is open |
| X2/3 | IN ← ○ | 12Vdc | |
| X2/2 | GND ● ○ | Gnd | External Maintenance Bypass switch (IA1) Option Min. contact load 20mA |
| X2/1 | IN ← ○ | 18Vdc | |

4 Operation

4.1 Introduction

4.1.1 Commissioning

The Kohler PW 8000DPA ST UPS is a high quality, complex electronic system which must be commissioned by an authorised Kohler Uninterruptible Power engineer before it is put into use.

The commissioning engineer will:

- connect the UPS batteries
- check the UPS electrical and mechanical installation, and operating environment
- check the UPS configuration settings
- check the installation and operation of any optional equipment
- perform a controlled UPS start-up
- fully test the system for correct operation
- provide customer operator training and equipment handover



WARNING: Kohler Uninterruptible Power will not accept responsibility for the equipment or the safety of any personnel if the UPS system is operated before it has been fully commissioned. The manufacturer's warranty will be invalidated if power is applied to any part of the UPS system before it has been fully commissioned and handed over to the customer.

4.1.2 Operating procedure summary

Under normal circumstances all the UPS modules are turned on and operating in their 'on-inverter' mode. If one module fails in a redundant module system the faulty module shuts down but the remaining module(s) continue to operate normally and provide protected load power.

If a UPS module fails in a capacity (or single module) system, the load immediately transfers to the static bypass supply (in all modules) and is supplied with unprotected bypass mains power.

A parallel-cabinet UPS system requires the installation of an external maintenance bypass circuit which wraps around the entire UPS system – an external maintenance bypass is optional in a single cabinet installation. The external maintenance bypass is bespoke to the installation and installed in a separate 'Maintenance Bypass' cabinet or switchgear panel (see *paragraph 3.4.4*). If an external maintenance bypass is installed you should familiarise yourself with its operating procedures before using the UPS operating procedures contained in this chapter.



CAUTION: In a multi-cabinet system always use the external maintenance bypass facility. DO NOT operate the cabinets' internal maintenance bypass switch (IA1).

Note: All the switches and control panel operations mentioned in this chapter are identified and described in chapter 2.

The commissioning engineer will hand-over the system in a fully working condition with all the UPS modules turned on and operating in the 'on-inverter' mode (or ECO mode, if appropriate).

4.1.3 General warnings



WARNING: The procedures given below must be performed by a trained operator.



WARNING: When the UPS system is operating on BYPASS or via the MAINTENANCE BYPASS SWITCH, the load supply is unprotected if the bypass mains supply fails. It is essential that the load user is informed of this possibility before you select these operating modes.



WARNING: When the UPS is shut down, power is still applied to the UPS modules and the cabinet input/bypass terminals unless the input/bypass mains is isolated at the external UPS input switchgear panel. In a single cabinet installation it is not permissible to turn off the external input/bypass mains supply when the load is connected via the internal maintenance bypass switch (IA1) as this will remove the load power.

4.2 Operating instructions

IMPORTANT NOTE

In the following procedures, all references to the 'Maintenance Bypass Switch' apply to the internal maintenance bypass switch (IA1) in the case of a single cabinet if it is not connected to an external maintenance bypass facility. If an external maintenance bypass facility is installed (standard in a parallel-cabinet system) they apply to the maintenance bypass switch in the external facility.

Under normal operating conditions all the UPS power modules are running and operating in the on-inverter mode.

This chapter contains the following procedures:

- How to start the UPS system from a fully powered-down condition (*see paragraph 4.3*).
- How to start the UPS system when it is initially operating on the maintenance bypass (*see paragraph 4.4*).
- How to transfer the load to the maintenance bypass and stop the system – (*see paragraph 4.5*).
- How to shut down the entire UPS system (*see paragraph 4.6*).

4.3 How to start the UPS system from a fully powered-down condition

In order to reduce the possible effects of high inrush currents that might occur when the load is initially turned on, we recommend that you power-up the load when the UPS system is operating on maintenance bypass, as described in this procedure. In a parallel-cabinet system the maintenance bypass switch is external to the UPS cabinets and bespoke to the installation. You should familiarise yourself with the operation of the external maintenance bypass circuit operation before using this procedure.



CAUTION: In a multi-cabinet system always use the external maintenance bypass facility. DO NOT operate the internal cabinet maintenance bypass switches (IA1).

Initial conditions:

This procedure assumes the following initial conditions.

- The UPS maintenance bypass switch is open.
- The UPS input mains isolator (and bypass mains isolator in a split bypass system) at the input switchgear panel is open.
- The UPS output isolator at the switchgear panel is open.

Powering-up the load:

1. Close the UPS input mains isolator (and bypass mains isolator in a split bypass system) at the mains switchgear panel.
 - a) Power will be applied to the UPS modules, but they will be turned OFF.
2. On every module control panel, verify that:
 - a) The LINE 1 LED is green.
 - b) The BATTERY LED is flashing red.
 - c) All other mimic LEDs are OFF
 - d) The LCD displays LOAD OFF, SUPPLY FAILURE.
If necessary press the RESET button to obtain this display.
3. Close the UPS output isolator at the output switchgear panel.
4. Close the UPS maintenance bypass switch.
5. Turn on the load equipment.
 - a) The load is now powered through the maintenance bypass.
 - b) The module control panel mimic indications do not change.
 - c) The LCD displays MANUAL BYP IS CLOSED.
6. Press the RESET button.
 - a) The LCD displays LOAD OFF, SUPPLY FAILURE.

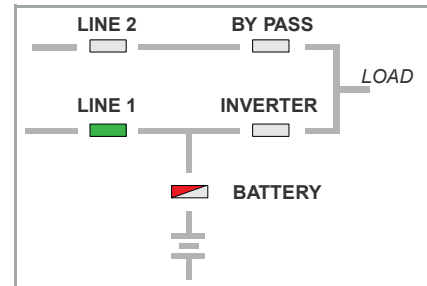

Starting the UPS Modules

7. Repeat steps 8 to 11 on every UPS module
8. On the module control panel, press and release both ON/OFF buttons. The UPS will begin to power up over approximately 60s.
9. On the module control panel, after 60s verify that:
 - a) The LINE 2 LED is green (red during initial start-up).
 - b) The BYPASS LED is green.
 - c) The INVERTER LED is red.
 - d) The BATTERY LED is flashing red.
 - e) The LCD displays LOAD NOT PROTECTED.
10. Close the battery isolator for the UPS module in the UPS cabinet, or in the external battery cabinet/rack, as applicable.
11. On the module control panel, verify that:
 - a) The BATTERY LED flashes green then changes to a steady green after up to 5 minutes.
12. Ensure that ALL the UPS modules are in the state shown above before continuing with this procedure.

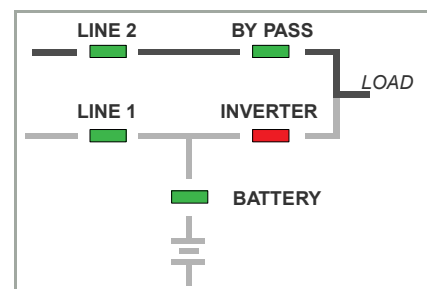
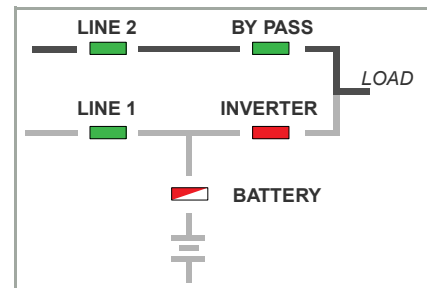

Transferring the load to the UPS from the Maintenance Bypass:

13. Ensure that the BYPASS LED is green (*on all UPS modules*).

4.5 How to transfer load to maintenance bypass then shut down the UPS system

The UPS modules can be turned off and the load transferred to the maintenance bypass supply when troubleshooting a 'system level' fault or replacing a UPS module in a 'capacity' rated system.

Initial conditions:

This procedure assumes one of the following initial conditions.

1. The UPS system is operating normally and all modules are on-inverter – continue with step 3:
 - a) The BYPASS LED is OFF.
 - b) The INVERTER LED is green.
 - c) The LCD displays LOAD PROTECTED.
If anything other than LOAD PROTECTED is displayed then press the RESET button, and if LOAD PROTECTED is still not displayed there is a problem with the UPS system and you should seek assistance!

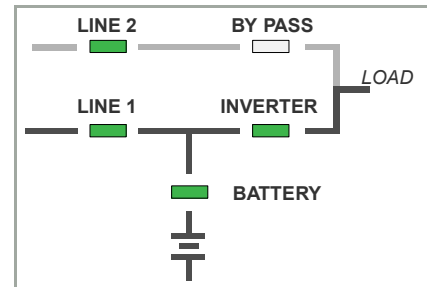

2. The UPS system has transferred the load to bypass due to a system fault, loss of redundancy or operating in ECO mode – continue with step 6:
 - a) The INVERTER LED is OFF.
 - b) The BYPASS LED is green.
 - c) The LCD displays LOAD NOT PROTECTED.

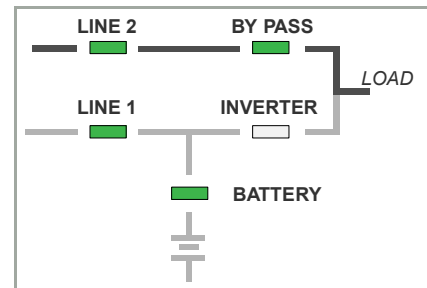

Transferring the UPS to the on-bypass mode:

3. On the module control panel (*of any module*):
 - a) Press the UP key once to access the menu system.
 - b) Use the UP / DOWN keys to move the cursor so that it is adjacent to COMMANDS and then press the ENTER key.
 - c) Use the UP / DOWN keys to move the cursor so that it is adjacent to LOAD TO BYPASS then press the ENTER key.
4. All UPS modules will simultaneously transfer the load to the static bypass.
5. On every module control panel, verify that:
 - a) The INVERTER LED is OFF.
 - b) The BYPASS LED is green.
 - c) The LCD displays LOAD NOT PROTECTED.

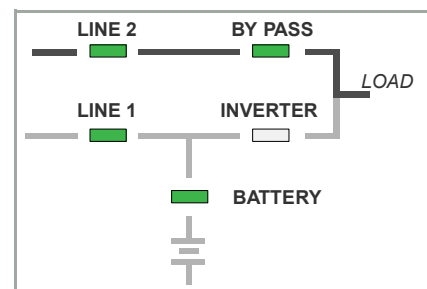

Closing the maintenance bypass switch:

6. Close the maintenance bypass switch.
7. On every module control panel, verify that:
 - a) The INVERTER LED is red.
 - b) The BYPASS LED is green.
 - c) The LCD displays MANUAL BYP IS CLOSED.
 - d) The audible alarm activates.
8. Press the RESET button (*on all UPS modules*) to cancel the audible alarm.
 - a) The LCD display should indicate LOAD NOT PROTECTED.

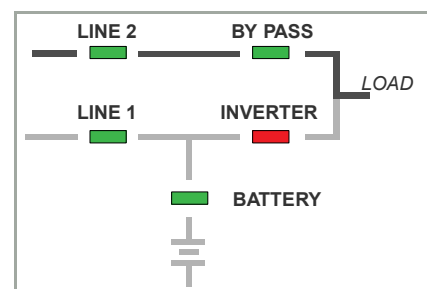

Powering down a UPS module:

When the load is connected to the maintenance bypass supply the UPS module(s) can be turned OFF:

Note: Carry out the following steps on each UPS module in a parallel system.

9. On the module control panel simultaneously press both ON/OFF buttons.
10. On the module control panel, verify that:
 - a) The LINE 1 LED is OFF.
 - b) The BYPASS LED is OFF.
 - c) The INVERTER LED is OFF.
 - d) The BATTERY LED is green.
 - e) The LCD displays LOAD OFF, SUPPLY FAILURE.
If necessary press the RESET button to obtain this display.

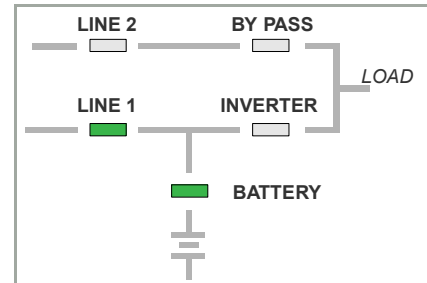

11. Open the battery isolator for the UPS module in the UPS cabinet or in the external battery cabinet/rack, as applicable.
12. On the module control panel, verify that:
 - a) The LINE 1 LED is green.
 - b) The BATTERY LED changes from green to flashing red (this may take up to 5 minutes).
 - a) All other mimic LEDs are OFF

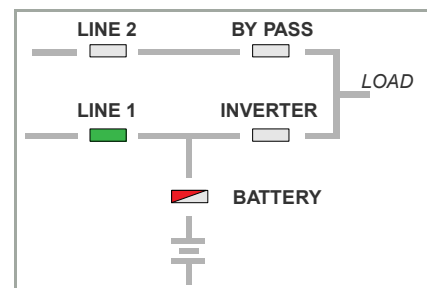

WARNING: If the internal cabinet maintenance bypass circuit is used, the cabinet's input and output power terminals remain live due to the closure of maintenance bypass switch (IA1).

4.6 How to shut down the complete UPS system

If the load does not require power for an extended period of time the UPS system can be shut down completely using the following procedure.

1. Isolate all load equipment by opening the load distribution fuses or circuit breakers.
2. Turn off the UPS modules and transfer the load to the maintenance bypass supply as described in paragraph 4.5, "How to transfer load to maintenance bypass then shut down the UPS system."
3. Isolate the load equipment.
4. Open the maintenance bypass switch.
5. Open the UPS output isolator at the switchgear panel.
6. Open the UPS input mains isolator (and bypass isolator in a split bypass system) at the input switchgear panel.
7. The UPS is now voltage free.

5 Maintenance

5.1 Introduction



WARNING: All the operations described in this chapter must be performed by suitably qualified personnel.

5.2 User responsibilities

There are no user-serviceable parts contained within the UPS so the maintenance requirements to be carried out by the user are minimal, beyond ensuring that the local environment in which the UPS is operating is kept cool (20°C), clean and dust free.

5.3 Scheduled maintenance



WARNING: Preventative maintenance inspections involve working inside the UPS which contains hazardous AC and DC voltages, and should be performed only by an authorised engineer who has been trained by Kohler Uninterruptible Power.

It is essential that the UPS system and batteries receive regular preventative maintenance to maximise both the useful working life and system reliability. When the UPS is commissioned, the commissioning engineer will attach a service record book to the front of the UPS which will be used to log the full service history of the UPS.

It is recommended that the UPS system is maintained every six months by a Kohler Uninterruptible Power trained engineer who will complete the following:

5.3.1 Preventative maintenance inspection

Preventative maintenance inspections form an integral part of all Extended Warranty Agreements (maintenance contracts) offered by Kohler Uninterruptible Power.

During a preventative maintenance inspection a trained Kohler Uninterruptible Power engineer will check and validate:

- site environmental conditions
- integrity of electrical installation
- cooling airflow
- load characteristics
- integrity of alarm and monitoring systems
- operation of all installed options
- check all event logs

5.3.2 System calibration

To ensure optimum UPS operation and efficient load protection we recommended that the system's operating parameters are checked and recalibrated where necessary.

During a system calibration a trained Kohler Uninterruptible Power engineer will check:

- rectifier operation and calibration
- inverter operation and calibration
- bypass operation
- battery status and battery test

5.3.3 Battery maintenance and testing

The batteries should be checked and tested by a trained Kohler Uninterruptible Power engineer every six months, depending on the ambient temperature.

The battery test takes approximately two minutes to complete and can be performed only if:

- there are no alarm conditions present
- the battery is fully charged
- the UPS input mains supply is present

The battery test procedure can be carried out from the UPS front panel and performed irrespective of the UPS operating mode (ON-INVERTER or ON-BYPASS/ECO) and whether or not the load is connected.

Battery disposal and recycling

Batteries contain dangerous substances that can harm the environment if disposed of carelessly. If you have reason to change the batteries, always consult with your local environmental waste disposal organisations to obtain the recommended disposal and recycling information.

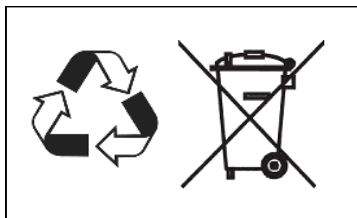

6 Troubleshooting

6.1 Alarms

If an alarm condition occurs, the red ALARM LED will illuminate on the module control panel and the audible alarm will sound. In this case proceed as follows:

1. Silence the audible alarm by pressing the RESET button.
2. Identify the cause of the alarm by viewing the events register in the main menu (*see page 19*).
3. In case of doubt, contact your nearest service agent or call Kohler Uninterruptible Power on +65 6302 0702.

IMPORTANT NOTE

Certain alarm conditions may 'latch-on' even after the cause of the alarm is no longer present. For example, if there is a brief mains failure during unattended operation the MAINS RECT FAULT alarm will activate and it may still indicate a fault condition even after the mains supply has returned to normal.

If any of the following alarms appear, the first action to take is to attempt to RESET it.

- MAINS RECT FAULT
- MAINS BYP FAULT
- BYPASS IS OK
- BYPASS IS NOT OK

If the alarm resets then it was probably caused by a transient condition and is no longer present; the UPS responded correctly and no further action is required. However, if it is not possible to reset the alarm, investigative action is necessary which may require assistance from the UPS Service department.

6.2 Menu, Commands, Event Log, Measurements

A detailed description of the Menu, Commands, Event Log and Measurements that can be operated and displayed on the LCD panel can be found on page 18.

6.3 Fault identification, rectification messages and alarms

| Alarm Condition | Meaning | Suggested Solution |
|----------------------|---|---|
| MAINS RECT. FAULT | Mains power supply is outside prescribed tolerance. | The input power to UPS is too low or missing. If site power appears to be OK, check the input circuit breakers etc. supplying the UPS. |
| MAINS BYP FAULT | Mains power supply is outside prescribed tolerance. | The input power to UPS is high/low or missing. If site power appears to be OK, check the input circuit breakers etc. supplying the UPS. |
| OUTPUT SHORT | There is a short circuit at the UPS output. | Check all output connections and repair as required. |
| OVERLOAD | Load exceeds the UPS rated power. | Identify which piece of equipment is causing the overload and remove it from the UPS. Do not connect laser printers, photocopiers, electric heaters, kettles etc. to the UPS. |
| TEMPERATURE HIGH | UPS temperature has exceeded the allowed value. | Check the ambient temperature of the UPS is less than 40°C. If the ambient temperature is normal call the authorised service centre for assistance. |
| INV. PHASE FAULT | Inverter is faulty. | Call the authorised service centre for assistance. |
| BATTERY IN DISCHARGE | Battery is near end of autonomy. | Turn off the load connected to UPS before the UPS switches itself off to protect its batteries. |
| BATT. DISCHARGE | Battery is fully discharged (normally as a result of a prolonged mains supply outage). UPS will transfer load to bypass if available. Otherwise the UPS will shut-down and drop the load. | Restore the UPS mains supply and restart the UPS. If a battery problem still exists, call the authorised service centre for assistance. |
| MANUAL BYP IS CLOSED | Maintenance Bypass closed. Load supplied by raw bypass mains. | This alarm is only displayed if the UPS is on Maintenance Bypass. |

6.4 Contacting service

Kohler Uninterruptible Power has a service department dedicated to providing routine maintenance and emergency service cover for your UPS.

We recommend that your UPS is protected by an Extended Warranty Agreement. These agreements assist us in caring for your UPS correctly, ensuring that it is well maintained and attended to promptly should any problems occur.

If you have any queries regarding your UPS please contact us.

Kohler Uninterruptible Power
7 Jurong Pier Road
Singapore
619159

Tel: +65 6302 0702

Email: serviceups.sg@kohler.com

7 Options

7.1 Introduction

The Kohler PW 8000DPA ST UPS has the following available options:

- Remote shut down facilities
- Generator ON facilities
- 1 x Customer-input function (customer defined)
- RCCMD shut down and management software
- SNMP Card for network management and remote monitoring
- Modem/Ethernet interface for UPS/site management software



CAUTION: When the UPS cabinet is installed as part of a parallel system the Customer Interface Board I/O is disabled in the 'slave' cabinets if the system 'Multidrop' application is enabled. Under such circumstances the required interface connections should be made to the board fitted in the 'master' module only – see page 14 for details.

7.2 Remote shut down

The remote shut down facility takes the form of a normally-open contact which closes to activate the UPS stop shut down sequence.

On leaving the factory the 'remote shut down' function is disabled and it must be enabled, if required, by setting a hardware code on the SETUP SERVICE menu. This should be carried out by the commissioning engineer. If you require this feature to be enabled after the system is commissioned please contact your distributor.

The remote shut down facility is connected to terminal port X1/7 – X1/8 on the communication card located on the Kohler PW 8000DPA ST front frame.

In order to allow the safe removal, maintenance or testing of the remote emergency stop device, without affecting the UPS operation, it is recommended that a terminal block with linking facilities is installed between the UPS and the remote shut down mechanism.

1. Use a screened cable with a single pair (0.5 mm²) and maximum length of 100 m.
2. Connect the cable as shown in Figure 7.1.

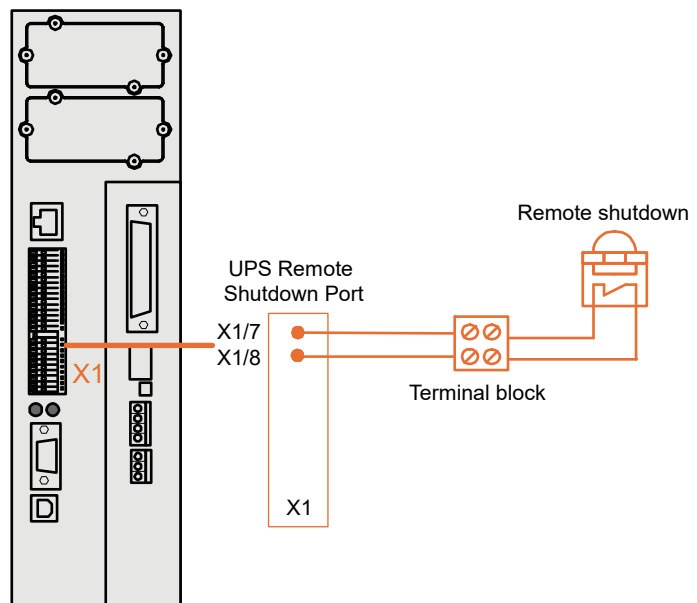

Figure 7.1 Remote shut down cabling



WARNING: The remote shut down facility should not be used as an 'Emergency Stop' because it will not turn off the UPS, or isolate the critical load, when the UPS is operating on its maintenance bypass.

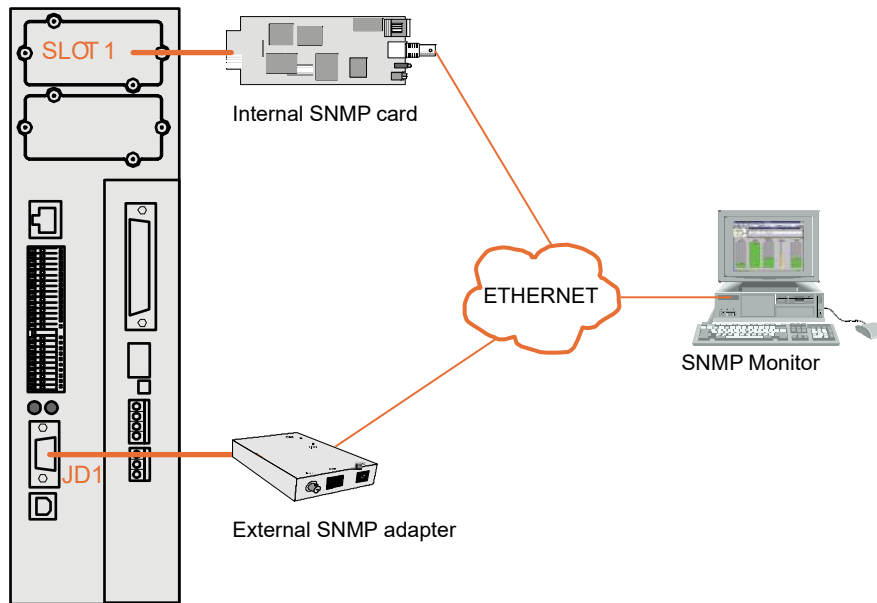

Figure 7.3 SNMP Internal and external adapters

7.5 Remote interlock (for external maintenance bypass only)

A key-operated remote interlock facility can be installed to prevent the external bypass switch from being closed before the UPS has been switched to the static bypass. This avoids the possibility of the UPS being damaged due to the closure of the external bypass switch while the UPS is operating on inverter.

The remote interlock circuit requires the maintenance bypass key-switch to be connected to auxiliary contacts of the internal maintenance bypass switch (IA1), as shown. This must be connected and functionally tested by a UPS Limited engineer.

This can be part of a wider interlocking system within the distribution design.

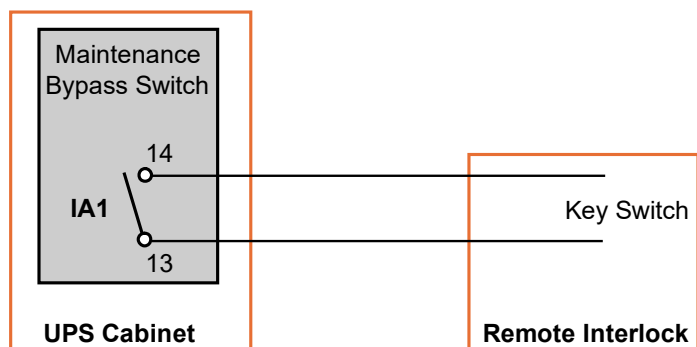
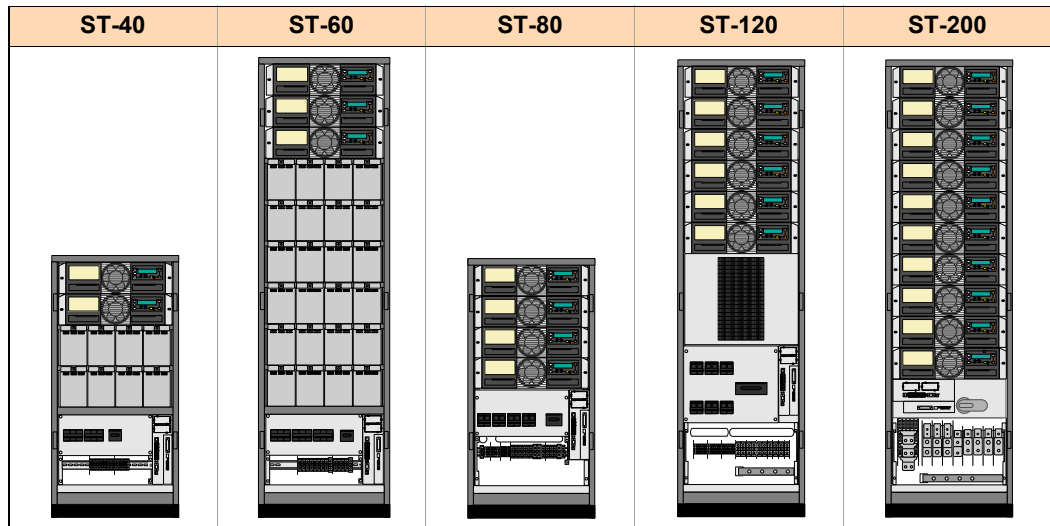

Figure 7.4 Remote interlock

8

Specification

8.1 Mechanical characteristics – UPS Cabinet



| | | ST-40 | ST-60 | ST-80 | ST-120 | ST-200 |
|--------------------------------------|----|--|--|---|---|--|
| Maximum configuration | | 2 module (10 or 20KW) + 80 x 7Ah batteries | 3 modules (10 or 20KW) + 240 x 7Ah batteries | 4 modules (10 or 20KW) NO batteries | 6 modules (10 or 20KW) NO batteries | 10 modules (10 or 20KW) NO batteries |
| Max. Power | kW | 40 | 60 | 80 | 120 | 200 |
| Dimensions (WxHxD) | mm | 550x1135x770 | 550x1975x770 | 550x1135x770 | 550x1975x770 | |
| Weight of empty cabinet | kg | 92 | 173 | 82 | 133 | 174 |
| Weight with modules and no batteries | kg | 130 up to 136 (with 2 Modules) | 229 up to 238 (with 3 Modules) | 157 up to 169 (with 4 Modules) | 245 up to 263 (with 6 Modules) | 360 up to 389 (with 10 Modules) |
| Max number parallel cabinets | | 4 | 4 | 4 | 3 | 2 |
| Max number of modules per system | | 8 | 12 | 16 | 18 | 20 |
| Max system capacity (no redundancy) | | 160kW | 240kW | 320kW | 360kW | 400kW |
| Colour | | Black (RAL 9005) | | | | |
| Operator access | | Front | | | | |
| Cable entry | | From the bottom | | | | |
| Protection class | | IP20 | | | | |

Battery data

| Battery characteristics | | 10KW UPS Module | 20KW UPS Module |
|---------------------------------------|-----|---|-----------------|
| Variable number of 12v battery blocks | No. | 30-50 | 40-50 |
| Maximum battery charger current | A | 4 A (6A Charger is optional) | |
| Battery charging curve | | Ripple free: IU (DIN 41773) | |
| Temperature compensation | | Standard (temp. sensor optional) | |
| Battery test | | Automatic and periodically (adjustable) | |
| Battery type | | VRLA or NiCd | |

| Battery capacity usage | 10KW UPS Module | | | 20KW UPS Module | | |
|--------------------------|-----------------|-------|-------|-----------------|-------|-------|
| Number of battery blocks | 30-32 | 30-32 | 34-50 | 40-46 | 40-46 | 48-50 |
| Max. Power in KW | 6 | 10 | 10 | 16 | 20 | 20 |
| Max. autonomy (min.) | any | 5 | any | any | 5 | any |

Standards

| Compliant standards | |
|-------------------------------|---|
| Safety | EN 62040-1-1, EN 60950-1 |
| Electromagnetic compatibility | EN 61000-6-4 Prod.standard: EN 62040-2 EN 61000-6-2 Prod.standard: EN 62040-2 EN 61000-4-2, EN 61000-4-3 - EN 61000-4-4 - EN 61000-4-5 - EN 61000-4-6 |
| Emission class | C3 |
| Immunity class | C3 |
| Performance | EN62040-3 |
| Product certification | CE |
| Degree of protection | IP 20 |

Options

| Communications options fitted as standard | |
|---|---|
| RJ45 Plug (Not used) | RJ45 Plug (for future options) |
| Customer interfaces: outputs DRY PORT X2 | 5 Volt-free contacts For remote signalling and automatic computer shutdown |
| Customer interfaces: inputs DRY PORT X1 | 1 x Remote Shut-down [EMERGENCY OFF (normally closed)] 1 x Programmable Customer Inputs 1 x GEN-ON (normally open) 1 x Temperature sensor for battery charging control 1 x 12Vdc output (max 200mA) |
| Serial ports RS232 on Sub-D9 | 1 x system frame For monitoring integration in network management and service |
| USB | 1x For monitoring and software management |
| Slot for SNMP card | For monitoring and integration in network management |
| Slot for Modem/Ethernet card | For monitoring and integration in network management |

Multi-cabinet configuration

The Kohler PW 8000DPA ST may be paralleled to increase the power capacity up to 400kW in steps of 10 or 20kW. A maximum of 20 modules can be paralleled, into four UPS cabinets.

The following system configurations are available

| PW8000DPA ST Series 2 system | ST-40 | ST-60 | ST-80 | ST-120 | ST-200 |
|--|-------|-------|-------|--------|--------|
| Number of modules per cabinet | 2 | 3 | 4 | 6 | 10 |
| Parallel cabinets per system | 4 | 4 | 4 | 3 | 2 |
| Maximum number of modules per system | 8 | 12 | 16 | 18 | 20 |
| Maximum total system capacity w/o redundancy | 160kW | 240kW | 320kW | 360kW | 400kW |