

# Kohler PW 5000/TP (10–50 kVA)

## User Manual









# Table of contents

|  |          |
|--|----------|
| <b>1: Safety</b>   | <b>1</b> |
| 1.1 Description of symbols used in this manual                 | 1        |
| 1.2 User precautions   | 1        |
| <b>2: Description</b>  | <b>2</b> |
| 2.1 Reliability and Quality Standards                          | 2        |
| 2.2 Kohler PW 5000/TP Model Range                              | 2        |
| 2.2.1 Single/Multi-cabinet configurations                      | 3        |
| 2.3 Advanced Design Features                                   | 3        |
| 2.3.1 Input booster technology                                 | 3        |
| 2.3.2 Flexible battery management                              | 3        |
| 2.3.3 Decentralized Parallel Architecture (DPA)                | 3        |
| 2.4 Warranty   | 4        |
| 2.5 Extended Warranty  | 4        |
| 2.6 Additional Service/Maintenance Support                     | 4        |
| <b>3: Installation</b>   | <b>5</b> |
| 3.1 Introduction   | 5        |
| 3.2 Receipt of the UPS   | 5        |
| 3.2.1 Site transportation                                      | 5        |
| 3.2.2 Unpacking the UPS  | 6        |
| 3.2.3 Batteries  | 6        |
| 3.3 Storage  | 7        |
| 3.3.1 UPS storage  | 7        |
| 3.3.2 Battery  | 7        |
| 3.4 Positioning  | 7        |
| 3.4.1 Planning the installation                                | 7        |
| 3.5 UPS Power Cabling  | 9        |
| 3.5.1 General requirements (preparation and planning)          | 9        |
| 3.6 Connecting the UPS input supply                            | 17       |
| 3.6.1 Safety notes   | 17       |
| 3.6.2 Preparation for the input cabling                        | 17       |
| 3.6.3 Connecting the UPS input power cables                    | 17       |
| 3.7 Connecting the UPS output                                  | 18       |
| 3.7.1 Safety notes   | 18       |
| 3.7.2 Preparation for the output cabling                       | 18       |
| 3.7.3 Connecting the UPS output cables                         | 19       |
| 3.8 Battery connections  | 23       |
| 3.8.1 Remote battery enclosures                                | 23       |
| 3.8.2 Connecting the external battery enclosure                | 23       |
| 3.9 Multi-module control cabling and configuration             | 25       |
| 3.9.1 Connecting the parallel communication cables (Bus-lines) | 25       |
| 3.10 Module interfacing facilities                             | 26       |
| 3.10.1 JD1 Smart Port – Serial RS 232 and USB Port             | 26       |
| 3.10.2 X1 Dry Port (volt-free contacts)                        | 27       |

|           |   |           |
|-----------|---|-----------|
| 3.10.3    | JR1 / RS485 INTERFACE FOR MULTIDROP                           | 27        |
| 3.10.4    | X2 Dry Port – Optional Output Interfaces Terminal Block (X2)  | 28        |
| <b>4:</b> | <b>Operation</b>  | <b>29</b> |
| 4.1       | Commissioning   | 29        |
| 4.2       | Control Panel   | 29        |
| 4.2.1     | Power Management Display (PMD)                                | 29        |
| 4.2.2     | Mimic LED indicators  | 30        |
| 4.2.3     | Operator keys   | 30        |
| 4.3       | Description of the LCD display                                | 31        |
| 4.3.1     | Status screens  | 31        |
| 4.3.2     | Main menu screen  | 32        |
| 4.3.3     | Event log menu screen   | 32        |
| 4.3.4     | Measurements menu screen                                      | 32        |
| 4.3.5     | Commands menu screen  | 33        |
| 4.3.6     | UPS Data menu screen  | 33        |
| 4.3.7     | Set-up User menu screen                                       | 34        |
| 4.3.8     | Set-Up Service menu screen                                    | 34        |
| 4.4       | Operating Modes   | 35        |
| 4.4.1     | On-Line (Inverter) mode                                       | 35        |
| 4.4.2     | Bypass (Line-Interactive) mode                                | 35        |
| 4.4.3     | Maintenance Bypass Mode                                       | 36        |
| 4.4.4     | Multi-module configuration concept                            | 37        |
| 4.5       | Operating Instructions  | 38        |
| 4.5.1     | Transfer to Maintenance Bypass Mode                           | 38        |
| 4.5.2     | Starting the UPS system from the Maintenance Bypass           | 40        |
| 4.5.3     | Complete system shutdown                                      | 42        |
| 4.5.4     | Individual module start/stop procedure                        | 43        |
| <b>5:</b> | <b>Maintenance</b>  | <b>45</b> |
| 5.1       | Introduction  | 45        |
| 5.2       | System calibration  | 45        |
| 5.3       | User responsibilities   | 45        |
| 5.4       | Routine maintenance   | 45        |
| 5.5       | Battery Testing   | 46        |
| <b>6:</b> | <b>Troubleshooting</b>  | <b>47</b> |
| 6.1       | Alarms  | 47        |
| 6.2       | Menu, Commands, Event Log, Measurements,                      | 47        |
| 6.2.1     | Event Log Screen  | 48        |
| 6.2.2     | Fault Identification and Rectification Messages and Alarms    | 48        |
| 6.3       | Contacting Service  | 49        |
| <b>7:</b> | <b>Options</b>  | <b>50</b> |
| 7.1       | Introduction  | 50        |
| 7.2       | Remote Emergency Stop facilities                              | 50        |
| 7.3       | Generator ON facilities                                       | 51        |
| 7.4       | Temperature sensor for temperature-dependant battery charging | 52        |
| 7.5       | WAVEMON Shutdown and Management Software                      | 52        |
| 7.5.1     | Why is UPS Management important?                              | 52        |
| 7.5.2     | WAVEMON Shutdown and Monitoring Software                      | 52        |
| 7.6       | SNMP CARD/ADAPTOR For Network Management/Remote Monitoring    | 54        |

|  |           |
|--|-----------|
| <b>8: Specifications</b>                   | <b>56</b> |
| 8.1 Mechanical                             | 56        |
| 8.2 Input Characteristics                  | 57        |
| 8.3 Output Characteristics                 | 57        |
| 8.4 Battery Characteristics                | 58        |
| 8.5 Environmental                          | 58        |
| 8.6 Heat Dissipation With Non-Linear Loads | 59        |
| 8.7 Standards                              | 59        |
| 8.8 Communication Options                  | 59        |
| 8.9 Fuses & Cables Quick Reference         | 60        |



# 1 Safety

## 1.1 Description of symbols used in this manual



**WARNING:** The warning symbol is used where there is danger of an electrical shock, equipment damage or personal-injury.



**CAUTION:** The caution symbol is used to highlight important information to avoid possible equipment malfunction or damage.

## 1.2 User precautions



**WARNING:** Keep this manual with the UPS for future reference.



**WARNING:** The UPS and peripheral equipment must be installed and commissioned by suitably qualified and trained personnel who are aware of the potential shock hazards.



**WARNING:** Do not attempt to install this UPS system until you are satisfied that ALL the safety instructions and hazard warnings contained in this manual are read and fully understood.



**WARNING:** High leakage current!  
Ensure that the UPS has been correctly earthed before you connect the mains power supply!



**WARNING:** This UPS must not be started-up or put into use without having first been commissioned by a fully trained engineer authorised by the manufacturer.



**WARNING:** All servicing must be performed by qualified personnel. Do not attempt to service the UPS yourself. You run risk of exposure to dangerous voltages by opening or removing the UPS-covers! Kohler Uninterruptible Power will assume no responsibility nor liability due to incorrect operation or manipulation of the UPS.



**WARNING:** The Kohler PW 5000/TP is a Class A UPS product (according to BS EN 62040-2:2006). In a domestic environment the UPS may cause radio interference. In such an environment the user may be required to undertake additional measures.

# 2 Description

## 2.1 Reliability and Quality Standards

Congratulations on your purchase of the Kohler PW 5000/TP UPS.

The Kohler PW 5000/TP UPS represents a completely new generation of mid-range, 3 phase UPS-Systems, incorporating the latest technological developments in power engineering. It is an advanced double conversion UPS, VFI (Voltage and Frequency Independent) topology that responds fully to both highest availability and environmentally friendly requirements compliant with IEC 62040-3 (VFI-SS-111) standards. High reliability, upgrade ability, low operating costs and excellent electrical performance are only some of the highlights of this innovative UPS solution.

Kohler Uninterruptible Power specialises in the design, building, installation and maintenance of Uninterruptible Power Systems. This compact and powerful UPS is just one example of our wide range of state-of-the-art power protection devices and will provide your critical equipment with a steady and reliable power supply for many years.

The criteria and methods which are used in the manufacture and maintenance of UPS systems are certified to International Standard ISO 9001/EN 29001 and ISO 14001. A full UPS Specification is given in Chapter 8 this manual.

## 2.2 Kohler PW 5000/TP Model Range

The Kohler PW 5000/TP UPS range covers 10, 15, 20, 25, 30, 40 and 50kVA models, in three different sized cabinets, that can be employed in a Single or Multi-Module configuration.



Figure 2.1 Kohler PW 5000/TP Cabinet details

### 2.2.1 Single/Multi-cabinet configurations

The Kohler PW 5000/TP UPS may be configured to operate as a single cabinet or several (up to 20) cabinets can be connected in parallel to operate as a multi-module UPS system. A multi-module configuration is selected either to increase the system's total power capacity or to provide module redundancy. This manual describes the installation, configuration and operation of both single and multi-module systems.

*Note: Although the UPS single/multi configuration can be modified in the field it is generally specified on ordering so that the module can be configured and fully tested in the factory prior to despatch.*

## 2.3 Advanced Design Features

### 2.3.1 Input booster technology

The UPS module's inbuilt advanced booster technology results in a perfect sinusoidal input power quality at 0.99 input power factor with a harmonic content of 3% THD(i). This leads to a more reliable total system operation and savings in generator and transformer sizing, as losses in the windings are minimised. It also means that traditional harmonic filters are no longer required.

The high power factor presented by the UPS on the incoming mains supply minimises cabling and fusing costs due to the resulting lack of reactive power consumption. This, together with the accompanying low harmonic currents, provide the following benefits:

- No additional losses in wires and cables.
- No extra heating of transformers and generators.
- No over sizing of generators.
- No false circuit breaker tripping and malfunction.
- No erratic operation of computers, telecommunication, monitors, electronic test equipment etc.
- No resonance with power factor correction capacitors.

### 2.3.2 Flexible battery management

This equipment employs a flexible battery management which avoids premature deterioration of battery life by advanced management of battery charging and preventive failure diagnostics.

The major benefits are:

- AC-ripple free battery charging due to a dc-dc charger separated from the rectifier and inverter.
- Wide range of number of battery blocks (22-50 blocks of 12V; depending on autonomy times).
- Wide UPS input voltage operating window extends the battery life due to fewer discharge cycles.
- Battery discharge protection caused by load jumps.
- Proactive battery protection from false manipulations and inadequate charging voltages.
- Proactive battery failure detection thanks to Advanced Battery Diagnosis (ABD) - Algorithm.
- User selectable battery tests.
- Optional temperature compensated charging to enhance battery life.

### 2.3.3 Decentralized Parallel Architecture (DPA)

The Kohler PW 5000/TP system features DPA paralleling technology that provides n+x redundancy without introducing a single-point-of-failure. The modules utilizing the DPA technology are completely autonomous by means of individual power units, bypasses, CPUs, control panels and separate battery configuration.

## 2.4 Warranty

The Kohler PW 5000/TP UPS is supplied with a limited warranty that the UPS and its component parts are free from defects in materials and workmanship for a period of one year from the date of original commissioning, or fifteen months from the date of original delivery, whichever is the sooner. This warranty is the only warranty given and no other warranty, express or implied, is provided.

This warranty is invalidated if the UPS is used without having first been commissioned by a fully trained and authorised person. This warranty does not apply to any losses or damages caused by misuse, abuse, negligence, neglect, unauthorised repair or modification, incorrect installation, inappropriate environment, accident, act of God or inappropriate application.

If the UPS fails to conform to the above within the warranty period then Kohler Uninterruptible Power will, at its sole option, repair or replace the UPS. All repaired or replaced parts will remain the property of Kohler Uninterruptible Power

As a general policy, Kohler Uninterruptible Power does not recommend the use of any of its products in life support applications where failure or malfunction of the product can be reasonably expected to cause failure of the life support device or to significantly affect its safety or effectiveness. Kohler Uninterruptible Power does not recommend the use of any of its products in direct patient care. Kohler Uninterruptible Power will not knowingly sell its products for use in such applications unless it receives in writing assurances satisfactory to Kohler Uninterruptible Power that the risks of injury or damage have been minimized, the customer assumes all such risks and the liability of Kohler Uninterruptible Power is adequately protected under the circumstances



**CAUTION:** The UPS system may contain batteries which must be re-charged for a minimum of 24 hours every six months to prevent deep-discharging. Batteries that have been, for whatever reason, deeply-discharged are not covered by the warranty.

## 2.5 Extended Warranty

The Standard Warranty may be enhanced by protecting the UPS with an Extended Warranty Agreement (maintenance contract). An Extended Warranty Agreement enhances the standard warranty by providing:

- Regular preventative maintenance inspections
- Guaranteed speed of response to operational problems
- 24 hour telephone support
- Fully comprehensive (excluding batteries) cover

Contact the Service Support Hotline on +65 6302 0702 for further details

## 2.6 Additional Service/Maintenance Support

If you are interested in obtaining an extended warranty for your Kohler PW 5000/TP, or require service/maintenance support for any other UPS you may have, please contact Kohler Uninterruptible Power at the following address:

Kohler Uninterruptible Power  
 7 Jurong Pier Road  
 Singapore  
 619159

---

Tel: +65 6302 0702

---

Email: [serviceups.sg@kohler.com](mailto:serviceups.sg@kohler.com)

# 3 Installation

## 3.1 Introduction

This chapter contains all the information necessary for the correct unpacking, positioning, cabling and installation of the Kohler PW 5000/TP UPS.



**WARNING:** All the operations described in this section must be supervised by an authorised electricians or suitably qualified person.

**WARNING:** Kohler Uninterruptible Power will take no responsibility for any personal or material damage caused by incorrect cabling or operations, or activities which are not carried out in strict accordance with the instructions contained in this manual.

## 3.2 Receipt of the UPS

The UPS and accessories are delivered on a specifically designed pallet that is easy to move with a forklift or a pallet jack.



**CAUTION:** When off loading the UPS always keep it in an upright position.

*Do not drop the equipment.*

*Do not stack the pallets due to the high-energy batteries involved and the heavy weight.*

The packing container protects the UPS from mechanical and environmental damage. This protection is further increased by wrapping the Kohler PW 5000/TP UPS with a plastic sheet.

Upon receiving the UPS, carefully examine the packing container and the UPS for any sign of physical damage. The outside 'Tip&Tel' ("FRAGILE" and "ARROW") indicator should be intact if the equipment has been transported in an upright position. In case of rupture (or if they are suspect) inform the carrier and Kohler Uninterruptible Power immediately.



**CAUTION:** Visible transport damages must be notified to the carrier immediately after receipt!

*Other claims for shipping damage must also be filed immediately and the carrier must be informed within 7 days of receipt of the equipment.*

*Packing materials should be stored for further investigation.*

Ensure that the received UPS corresponds to the description indicated in the delivery note.

### 3.2.1 Site transportation

If you transport the UPS equipment after it has been off-loaded (for example, for storage or moving to a different installation location) please observe the following precautions.



**CAUTION:** Potential dangers:

*– Do not tilt the UPS or Battery Cabinet by more than 10° as it might damage the equipment.*

*If the equipment has been tilted do not connect it to the mains electricity supply.*

*– The weight of the UPS system could cause serious injuries to personnel or other equipment in the surrounding area.*



**CAUTION:** Storage:

*– The UPS should be stored in the original packing and shipping carton.*

*– The recommended storing temperature for the UPS system and batteries is between +5°C and +40°C.*

*– The UPS system and the battery sets must be protected from humidity < 90% RH (non-condensing).*

### 3.2.2 Unpacking the UPS



**WARNING:** The UPS system, the battery cabinet (option) and the batteries are heavy and may tip during transportation causing serious injury if the unpacking instructions are not followed closely.

The cabinets are attached to a shipping pallet, wrapped in polythene and protected by a sturdy cardboard covering.



**CAUTION:** Before you finally unpack the equipment, remove any additional external shipping packaging and visually check that the 'Tip&Tel' indicator ("FRAGILE" and "ARROW") on the packing container is intact.

1. Ensure that the floor surface is level and suitable for wheeling and taking the heavy weight.
2. Remove cardboard packing container by pulling it upwards. The packaging will contain a wooden ramp.
3. Remove the protective plastic cover and any other packing around the UPS.
4. Remove the fixings securing the UPS to the pallet.
5. Position the enclosed ramp ('A' & 'B' cabinets) at the rear side of the cabinet and roll the UPS down the ramp.
6. Retain the packaging materials for future shipment of the UPS.
7. Examine the UPS for any sign of damage and notify your carrier or supplier immediately if damage is apparent.



**Figure 3.1 Unpacking cabinets A & B**

#### Checking the nameplate

Before proceeding, check that the technical specifications on the nameplate, situated on the rear of the UPS or behind the front internal door, corresponds to the purchased material mentioned in the goods delivery note.

### 3.2.3 Batteries

The batteries connected to the UPS are usually of a sealed, maintenance-free design. The batteries can be mounted either within the UPS, in an external battery cabinet, or on a bespoke battery rack, depending on the required autonomy time and paralleling arrangement. For optimum reliability a separate battery string should be connected to each individual UPS. The batteries are usually shipped separately and fitted by a manufacturer-approved engineer when the UPS is commissioned.

If the UPS is delivered without batteries, Kohler Uninterruptible Power is not responsible for any damage or malfunctioning caused to the UPS by the incorrect supply, storage, installation or connection of batteries by third parties.

### 3.3 Storage

#### 3.3.1 UPS storage

If you plan to store the UPS prior to use, it should be kept in a clean, dry environment with an ambient temperature between -25°C to +70°C and relative humidity of less than 90%.

If the UPS is removed from the packing container you must also ensure you protect it from dust.

#### 3.3.2 Battery

The storage capability of the UPS batteries depends greatly on the ambient temperature. It is important not to store the UPS batteries for longer than 6 months at 20°C, 3 months at 30°C or 2 months at 35°C storage temperature without recharging the battery.

For longer term storage the battery must be fully recharged every 6 months @20°C.



**CAUTION:** Sealed batteries must never be stored in a discharged or partially discharged state. Extreme temperature, under-charge, overcharge or over-discharge will destroy the batteries!



**Key Point:** Note the following:

- Charge the battery both before and after storing.
- Always store the batteries in a dry, clean, cool environment in their original packaging.
- If the packaging is removed protect the batteries from dust and humidity.

### 3.4 Positioning

#### 3.4.1 Planning the installation

A certain amount of pre-planning will help ensure smooth, trouble-free equipment installation. The following *guidelines* should be taken into account when planning a suitable UPS location and environment.

1. The equipment must be installed and transported in a upright position.
2. The floor at the installed location and en-route from the off-loading point must be able to safely take the weight of the UPS and battery equipment plus fork lift during transit. The floor material where the UPS is to be located should be non-flammable.
3. The UPS cabinet requires space to bottom/front and back to enable cooling airflow. Allow a minimum of 200mm clearance at the back of the cabinet. Suitable ventilation airflow (not exceeding +40°C) must be provided (see *Figure 3.2*).
4. All parts of the UPS requiring access for maintenance, servicing and user operation are accessible from the front and rear. Reserve a minimum of 900mm space at the front of the UPS cabinet.
5. A temperature of 20°C is recommended to achieve a long battery life.
6. Avoid high ambient temperature, moisture and humidity.

#### In summary

The UPS should be located where:

- a) Humidity (< 90% non-condensing) and temperature (+15°C / +25°C) are within prescribed limits.
- b) Fire protection standards are respected.
- c) Cabling can be performed easily.
- d) A minimum 900mm front accessibility is available for service or periodic maintenance.
- e) Requested air cooling flow is available.
- f) The air conditioning system can provide a sufficient amount of air cooling to keep the room at, or below, the maximum desired temperature.
- g) No dust or corrosive/explosive gases are present.
- h) The location is vibration free.
- i) If the UPS is to be installed in bayed enclosures, partition walls have to be installed.

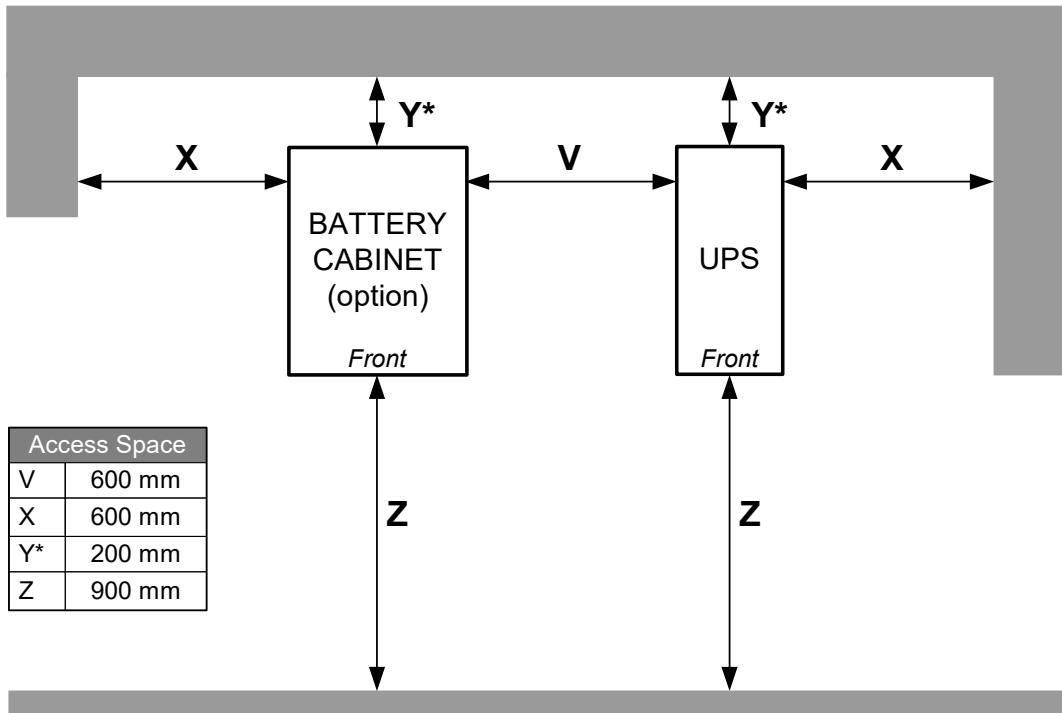

\*Although the diagram shows 200mm is required at the rear of the cabinet, 'A' and 'B' cabinets should be cabled such that the cabinet can be pulled forward to give access to the rear connections.

**Figure 3.2 UPS Space Recommendations**

|  |       | 10kVA | 15kVA | 20kVA | 25kVA | 30kVA | 40kVA | 50kVA |
|--|-------|-------|-------|-------|-------|-------|-------|-------|
| Heat Dissipation with 100% Non-linear Load per range (EN 62040-3)      | W     | 600   | 900   | 1100  | 1400  | 1700  | 2300  | 2900  |
| Heat Dissipation with 100% Non-linear Load per range (EN 62040-3)      | BTU/h | 2048  | 3072  | 3754  | 4778  | 5802  | 7850  | 9898  |
| Airflow (25°C - 30°C) with 100% Non-linear Load per range (EN 62040-3) | m³/h  | 150   | 150   | 150   | 150   | 570   | 570   | 570   |
| Heat Dissipation without load  | W     | 120   | 150   | 150   | 170   | 250   | 300   | 350   |

|                                   | Cabinet A                                      | Cabinet B    | Cabinet C                       | Batt Cab C   |
|-----------------------------------|--|--------------|---------------------------------|--------------|
| Dimensions (WxHxD)mm              | 345x720x710                                    | 345x1045x710 | 440x1420x910                    | 480x1420x940 |
| Maintenance/Service Accessibility | Top, rear, front, left and right side          |              | Top, front, left and right side |              |
| Positioning                       | Min. 200mm rear space required for ventilation |              |                                 |              |
| Input and Output Power Cabling    | From the bottom at the rear.                   |              | From the bottom at the front    |              |

## 3.5 UPS Power Cabling

### 3.5.1 General requirements (preparation and planning)

It is the customer's responsibility to provide all external fuses, isolators and cables used to connect the UPS input and output power supplies. The information in this section should help in the planning and preparation of the UPS power cabling.

The UPS input supply and bypass supply should be connected to the utility mains through a LV-Distribution board and protected by a circuit breaker or fuse. This provides overload protection and also a means of isolating the UPS from the mains supply when required. Similarly, the UPS output supply should be connected to the load equipment via a suitably fused output distribution panel.

The UPS can be wired with a 'single feed' input (standard), whereby the UPS input supply is internally connected to the UPS bypass circuit, or it can be wired with a 'dual feed' input – where the UPS bypass circuit is connected to a dedicated 'bypass' supply (see Figure 3.4).

Figure 3.4 identifies the UPS input/output cabling requirements and provides information regarding the necessary fuse and cable ratings, and cable sizing.



**Key Point:** This information is given for guidance only. All fuses, isolators and power cables must be rated and installed in accordance with the prescribed IEC standards or local regulation – e.g. BS7671.

Figures 3.6 and 3.7 show details of the power terminal connections within the UPS including connection sizes and recommended tightening torque. This illustration shows that the UPS unit requires the following power cables:

#### **Rectifier (In):**

- three-phase (1L1, 1L2, 1L3)
- neutral (1N)
- protective earth (PE) connection for the rectifier input

#### **Bypass (In) (Dual feed system only):**

- three-phase (2L1, 2L2, 2L3)
- neutral (2N)
- protective earth (PE) connection for the bypass if used as 'Dual Feed' input

#### **Load (Out):**

- three-phase (3L1, 3L2, 3L3)
- neutral (3N)
- protective earth (PE) connection for the load output

#### **External Battery:**

- Plus (+)
- Common (N)
- Minus (-)
- protective earth (PE) connection for the external batteries
- the UPS internal batteries must be disconnected if external batteries are used. Under no circumstances should external and internal batteries be connected together in parallel.

**Input neutral grounding**

**Key Point:** Input neutral is required to operate the rectifier.

In TN-S systems, no 4-pole input switches or circuit breakers should be used.

During battery operation the neutral must always be grounded.

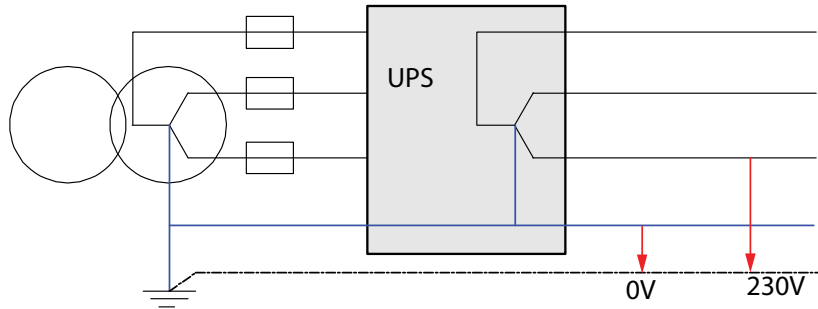

**Figure 3.3** Input neutral grounding

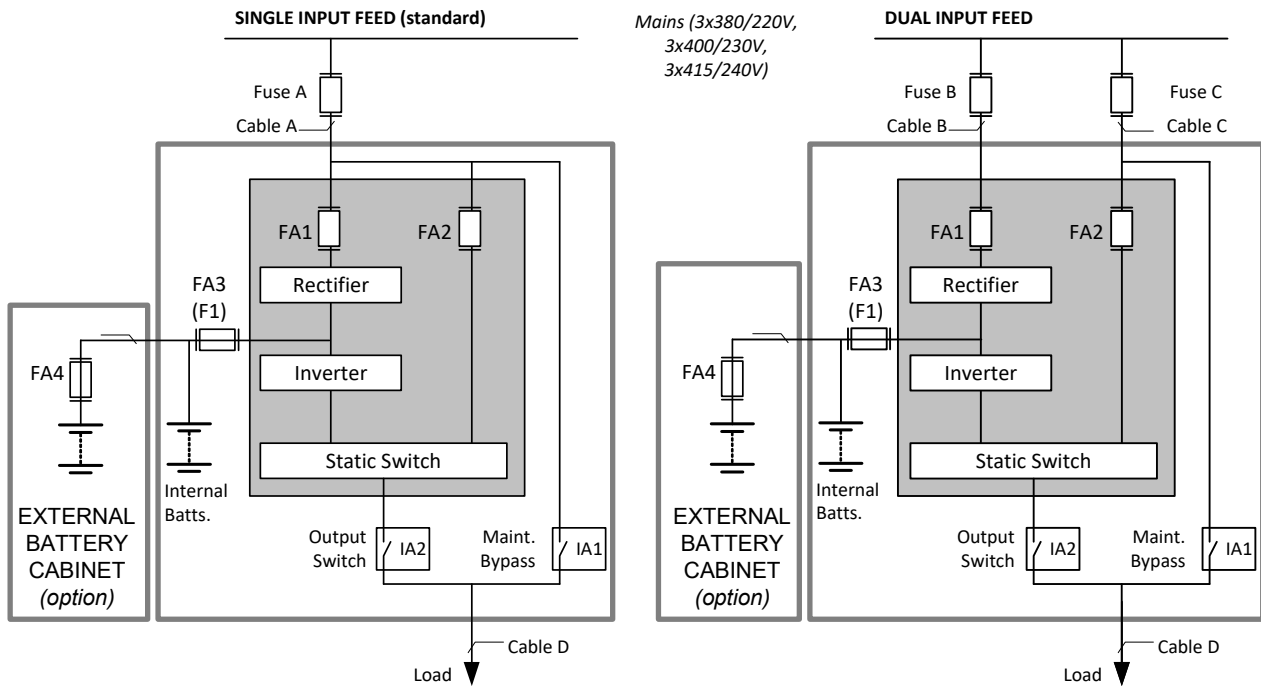

**SINGLE INPUT FEED**

| Power (kVA) | Fuse A (Agl/CB) (A) | Cable A (mm <sup>2</sup> ) | Cable D (mm <sup>2</sup> ) |
|-------------|---------------------|----------------------------|----------------------------|
| 10          | 3 x 20              | 5 x 2.5                    | 5 x 2.5                    |
| 15          | 3 x 32              | 5 x 4.0                    | 5 x 4.0                    |
| 20          | 3 x 40              | 5 x 6.0                    | 5 x 6.0                    |
| 25          | 3 x 40              | 5 x 6.0                    | 5 x 6.0                    |
| 30          | 3 x 63              | 5 x 10                     | 5 x 10                     |
| 40          | 3 x 80              | 5 x 25                     | 5 x 25                     |
| 50          | 3 x 80              | 5 x 25                     | 5 x 25                     |

**DUAL INPUT FEED**

| Power (kVA) | Fuse B (Agl/CB) (A) | Cable B (mm <sup>2</sup> ) | Fuse C (Agl/CB) (A) | Cable C (mm <sup>2</sup> ) | Cable D (mm <sup>2</sup> ) |
|-------------|---------------------|----------------------------|---------------------|----------------------------|----------------------------|
| 10          | 3 x 20              | 5 x 2.5                    | 3 x 20              | 5 x 2.5                    | 5 x 2.5                    |
| 15          | 3 x 32              | 5 x 4.0                    | 3 x 32              | 5 x 4.0                    | 5 x 4.0                    |
| 20          | 3 x 40              | 5 x 6.0                    | 3 x 40              | 5 x 6.0                    | 5 x 6.0                    |
| 25          | 3 x 40              | 5 x 6.0                    | 3 x 40              | 5 x 6.0                    | 5 x 6.0                    |
| 30          | 3 x 63              | 5 x 10                     | 3 x 63              | 5 x 10                     | 5 x 10                     |
| 40          | 3 x 80              | 5 x 25                     | 3 x 80              | 5 x 25                     | 5 x 25                     |
| 50          | 3 x 80              | 5 x 25                     | 3 x 80              | 5 x 25                     | 5 x 25                     |

Notes:

1. Fuse and Cable recommendations to IEC 60950-1:2001
2. The fuse and cable rating details in the above tables are a recommendation only.
3. The UPS must be installed to prescribed IEC or local regulations (e.g. BS7671).
4. External DC Cables and Battery fuses are bespoke to the installation.

**Figure 3.4 Kohler PW 5000/TP fuse & cable rating**

**Cabling a parallel system**

In order to achieve equal load sharing between the UPS-cabinets in a multi-cabinet installation, the input cables from the input distribution board to each UPS cabinet should be of equal length. Similarly the UPS output cables to the output distribution board should be of equal length (see Figure 3.5).

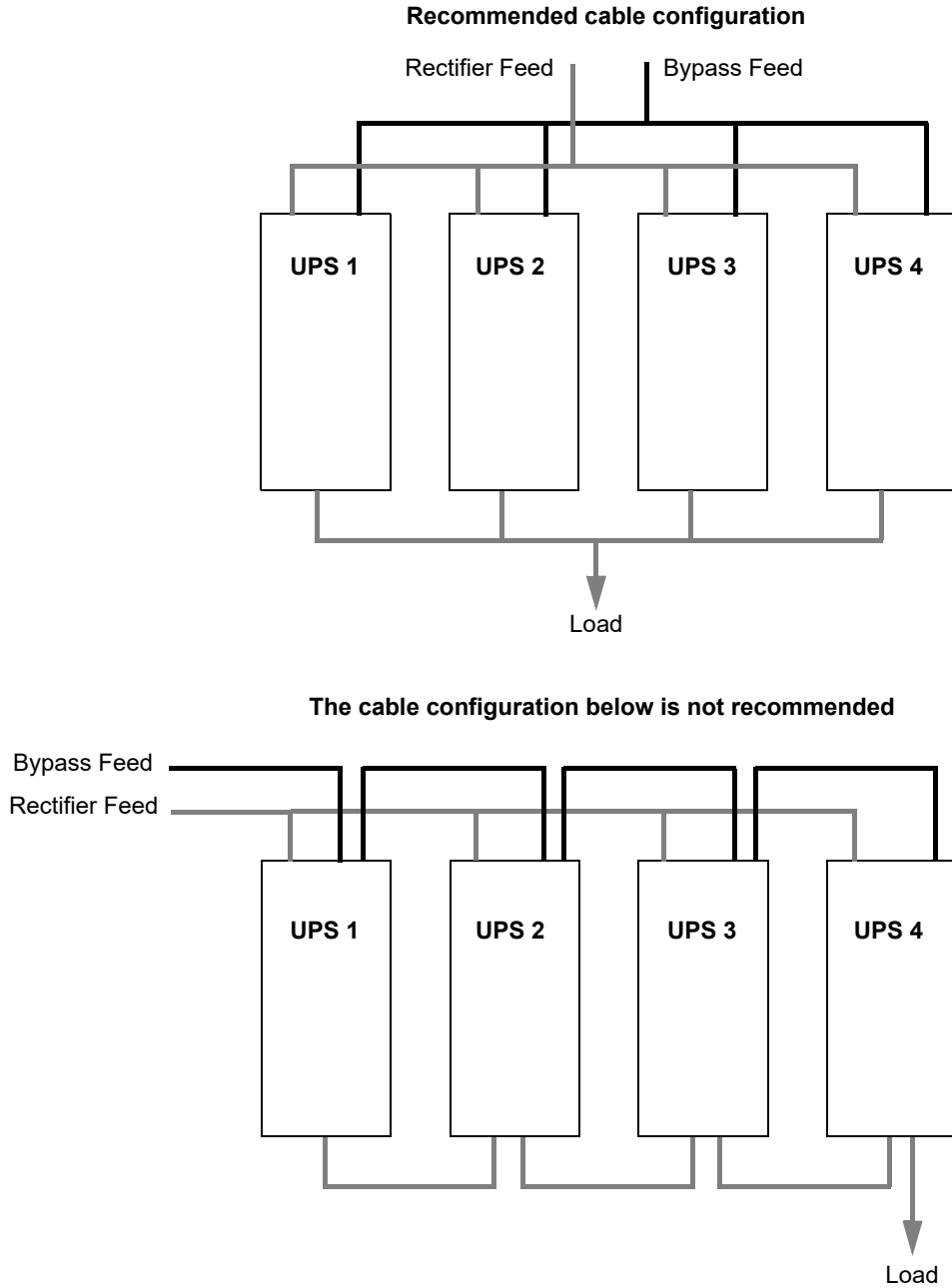
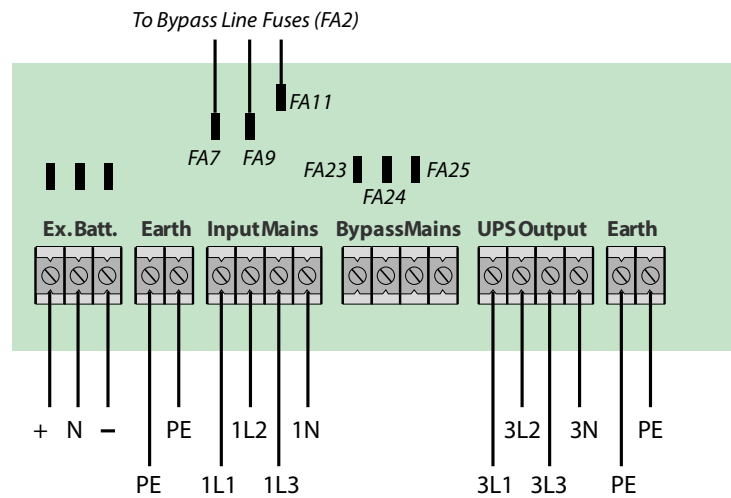

**Figure 3.5** Cable lengths for multi cabinet configurations (assuming a dual input supply)

**10kVA – 25kVA (Cabinets A & B)  
Power Connections (Single input feed)**

For models in this power range the external power connections are made to a row of terminals located on the UPS Filter Board which is accessible from the rear of the UPS module.

Note that the Single Input configuration requires the bypass line fuses to be connected to FA7/FA9/FA11 on the Filter Board. This is the standard configuration set when leaving the factory unless a dual input configuration is specified.



**10kVA – 25kVA (Cabinets A & B)  
Power Connections (Dual input feed)**

This illustration shows the connections for a Dual input configurations, with a separate mains supply connected to the Bypass Mains terminals.

Note that the Dual Input configuration requires the bypass line fuses to be connected to FA23/FA24/FA25 on the Filter Board. If necessary these cables will be reconfigured by the Commissioning Engineer as part of the commissioning procedure.

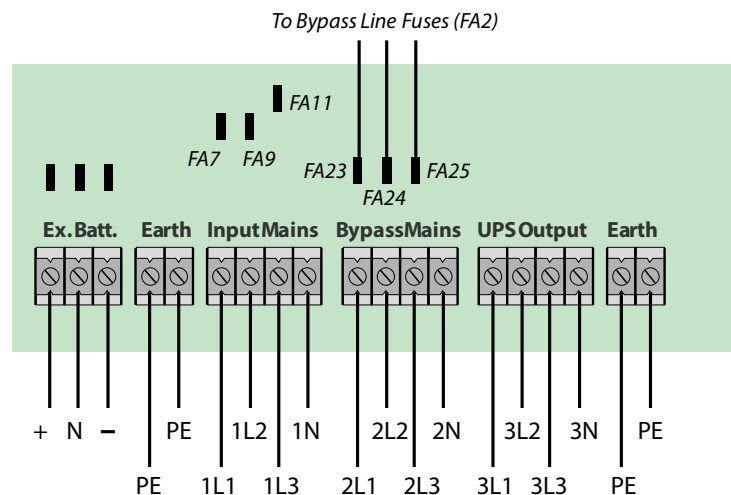

| UPS Range | Battery (+ / N / -) +PE | Input Bypass 3+N (N,2L1,2L2,2L3) | Input Rectifier 3+N+PE (N,1L1,1L2,1L3) | Output load 3+N+PE (N,3L1,3L2,3L3) | Max. cable section admissible | Tightening Torque (Nm) |
|-----------|-------------------------|----------------------------------|--|------------------------------------|-------------------------------|------------------------|
| 10-25kVA  | 4 x 16 mm <sup>2</sup>  | 4 x 16 mm <sup>2</sup>           | 5 x 16 mm <sup>2</sup>                 | 5 x 16 mm <sup>2</sup>             | 16 mm <sup>2</sup>            | 1.5                    |

Notes:

1. Fuse and Cable recommendations to IEC 60950-1:2001
2. The fuse and cable rating details in the above tables are a recommendation only.
3. The UPS must be installed to prescribed IEC or local regulations (e.g. BS7671)

Figure 3.6 10-25kVA Connection details

**30kVA – 50kVA  
(Cabinet C)  
Power Connections  
(Single input feed)**

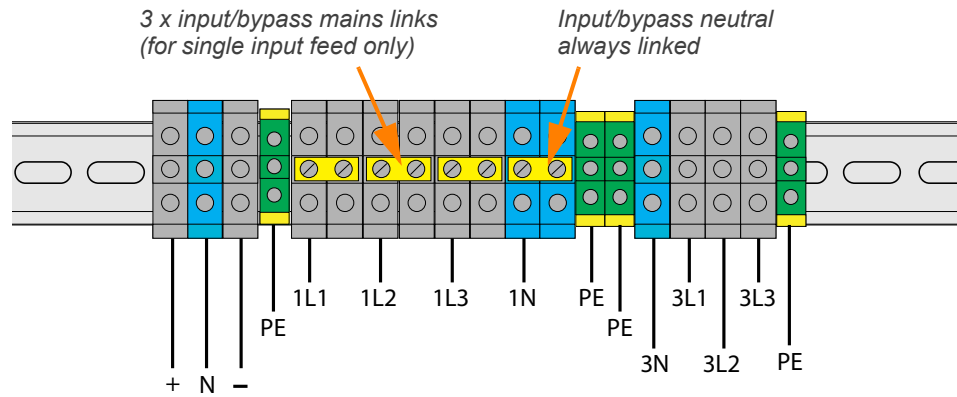

For models in this power range the external power connections are made to a row of terminals blocks mounted on a rail on the front of the UPS module.

Note that the Single Input configuration requires three links to be fitted between the input and bypass supply connections, as shown in the above illustration. This is the standard configuration set when leaving the factory unless a dual input configuration is specified.

**30kVA – 50kVA  
(Cabinet C)  
Power Connections  
(Dual input feed)**

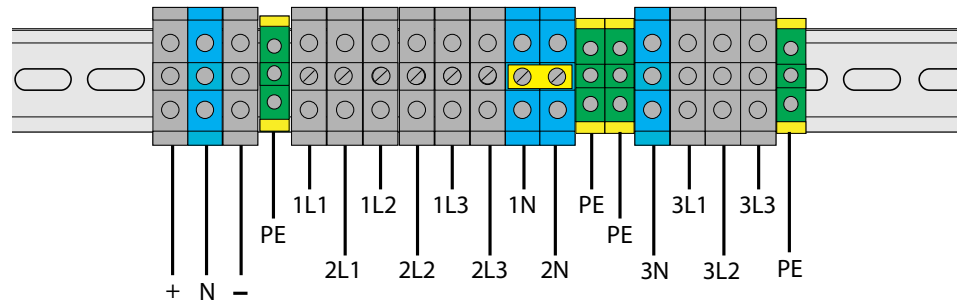

The above illustration shows the connections for a Dual input configurations, with a separate mains supply connected to the Bypass Mains terminals.

Note that the Dual Input configuration requires the links to be removed between in input and bypass terminals. If necessary these cables will be reconfigured by the Commissioning Engineer as part of the commissioning procedure.

| UPS Range | Battery (+ / N / -) +PE | Input Bypass 3+N (N,2L1,2L2,2L3) | Input Rectifier 3+N+PE (N,1L1,1L2,1L3) | Output load 3+N+PE (N,3L1,3L2,3L3) | Max. cable section admissible | Tightening Torque (Nm) |
|-----------|-------------------------|----------------------------------|--|------------------------------------|-------------------------------|------------------------|
| 30-50kVA  | 4 x 35 mm <sup>2</sup>  | 4 x 35 mm <sup>2</sup>           | 5 x 35 mm <sup>2</sup>                 | 5 x 35 mm <sup>2</sup>             | 35 mm <sup>2</sup>            | 3.5                    |

Notes:

1. Fuse and Cable recommendations to IEC 60950-1:2001
2. The fuse and cable rating details in the above tables are a recommendation only.
3. The UPS must be installed to prescribed IEC or local regulations (e.g. BS7671)

**Figure 3.7 30-50kVA Connection details**

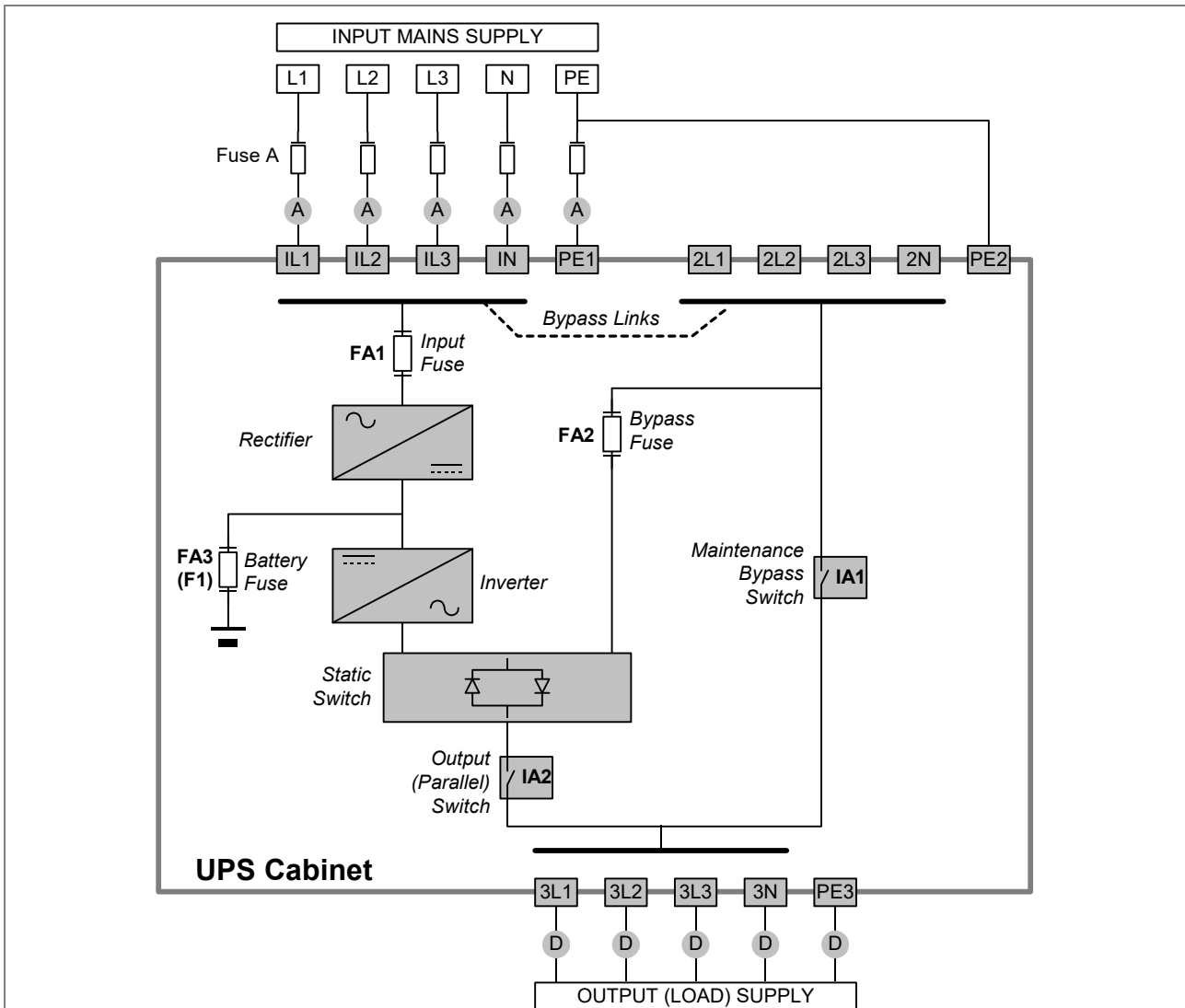

**SINGLE**

| Power (kVA) | Fuse A (Agl/CB) (A) | Cable A (mm <sup>2</sup> ) | Cable D (mm <sup>2</sup> ) |
|-------------|---------------------|----------------------------|----------------------------|
| 10          | 3 x 20              | 5 x 2.5                    | 5 x 2.5                    |
| 15          | 3 x 32              | 5 x 4.0                    | 5 x 4.0                    |
| 20          | 3 x 40              | 5 x 6.0                    | 5 x 6.0                    |
| 25          | 3 x 40              | 5 x 6.0                    | 5 x 6.0                    |
| 30          | 3 x 63              | 5 x 10                     | 5 x 10                     |
| 40          | 3 x 80              | 5 x 25                     | 5 x 25                     |
| 50          | 3 x 80              | 5 x 25                     | 5 x 25                     |

**INPUT FEED**

Notes:

1. Fuse and Cable recommendations to IEC 60950-1:2001
2. The fuse and cable rating details in the above tables are a recommendation only.
3. The UPS must be installed to prescribed IEC or local regulations (e.g. BS7671).

**Figure 3.8 Single input feed - power connection diagram**

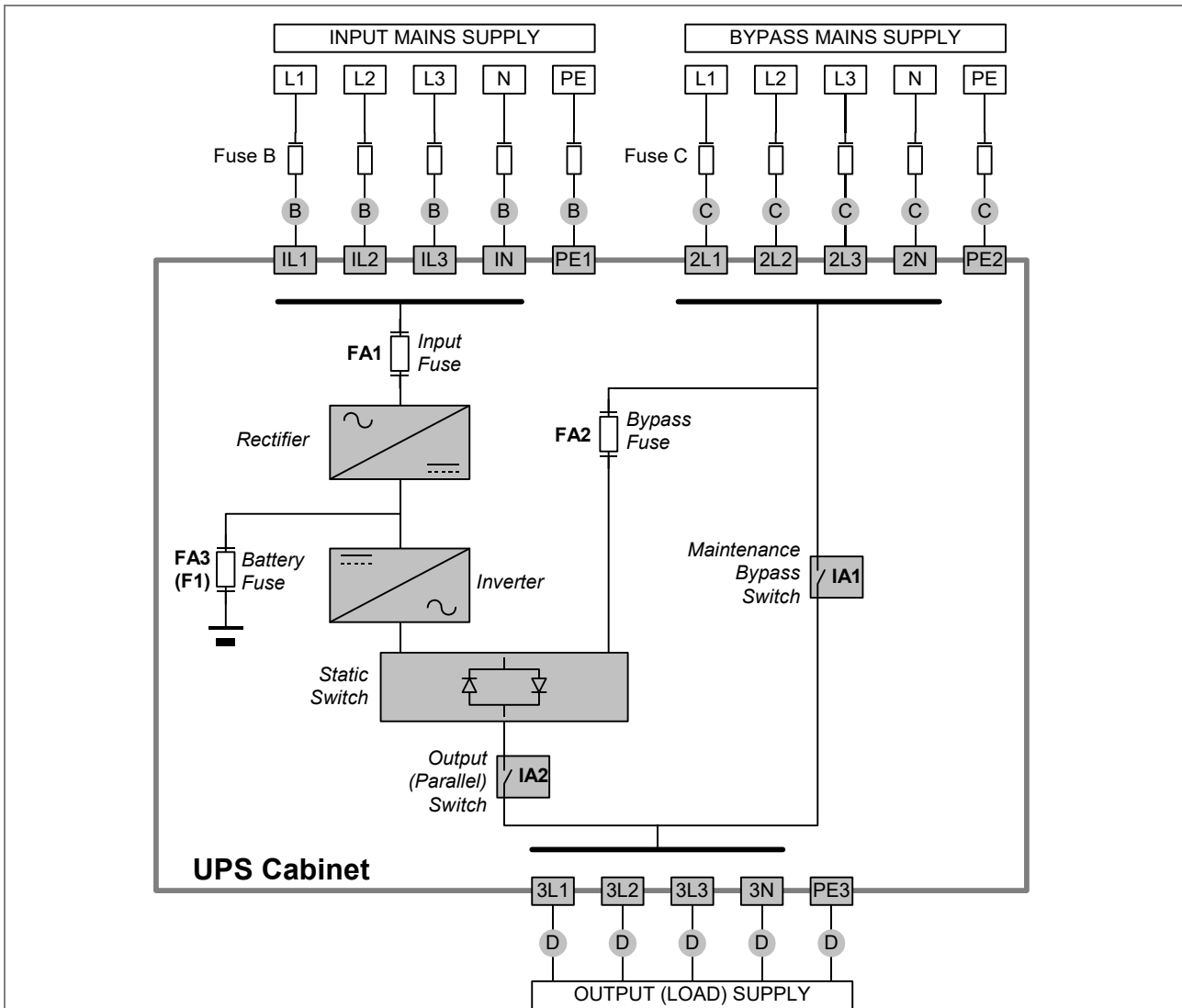

**DUAL**

| Power (kVA) | Fuse B (Agl/CB)(A) | Cable B (mm <sup>2</sup> ) | Fuse C (Agl/CB) (A) | Cable C (mm <sup>2</sup> ) | Cable D (mm <sup>2</sup> ) |
|-------------|--------------------|----------------------------|---------------------|----------------------------|----------------------------|
| 10          | 3 x 20             | 5 x 2.5                    | 3 x 20              | 5 x 2.5                    | 5 x 2.5                    |
| 15          | 3 x 32             | 5 x 4.0                    | 3 x 32              | 5 x 4.0                    | 5 x 4.0                    |
| 20          | 3 x 40             | 5 x 6.0                    | 3 x 40              | 5 x 6.0                    | 5 x 6.0                    |
| 25          | 3 x 40             | 5 x 6.0                    | 3 x 40              | 5 x 6.0                    | 5 x 6.0                    |
| 30          | 3 x 63             | 5 x 10                     | 3 x 63              | 5 x 10                     | 5 x 10                     |
| 40          | 3 x 80             | 5 x 25                     | 3 x 80              | 5 x 25                     | 5 x 25                     |
| 50          | 3 x 80             | 5 x 25                     | 3 x 80              | 5 x 25                     | 5 x 25                     |

**INPUT FEED**

Notes:

1. Fuse and Cable recommendations to IEC 60950-1:2001
2. The fuse and cable rating details in the above tables are a recommendation only.
3. The UPS must be installed to prescribed IEC or local regulations (e.g. BS7671).

**Figure 3.9 Dual input feed - power connection diagram**

### 3.6 Connecting the UPS input supply



**WARNING:** Opening or removing the UPS-covers will create the risk of exposure to dangerous voltages if power is connected to the UPS.

#### 3.6.1 Safety notes

Please ensure you read and understand the following safety notes before you begin the UPS electrical installation.

1. All operations detailed in this section must be performed by an authorised electrician or qualified personnel.
2. Once the electrical installation is completed the initial UPS start-up must be performed by qualified personnel authorised by the manufacturer.
3. Do not operate the UPS if there is water or moisture present.
4. When carrying out any work on the UPS input power cables you must ensure that the UPS supplies are isolated at the supply distribution panel and, where possible, locked out. Warning notices should be posted where applicable to prevent inadvertent operation of the input supply isolators.

#### 3.6.2 Preparation for the input cabling

Before you start connecting the UPS input cables:

- Ensure that the provided fuses and cables satisfy the ratings shown in Figures 3.4, 3.6 and 3.7, and are in accordance with the prescribed IEC Standards or local regulations (e.g. BS7671).
- Do not commence this procedure until the UPS is properly installed at its intended location.

#### 3.6.3 Connecting the UPS input power cables

1. To protect personnel during the UPS installation ensure that the connections are performed under the following conditions:
  - a) No mains voltage is present.
  - b) Loads are shut down and disconnected.
  - c) The UPS is shut down and voltage-free.
  - d) The UPS Maintenance Bypass Isolator IA1 is OFF.
  - e) The UPS Output/Parallel Isolator IA2 is OFF.
2. Gain access to the UPS power terminals.
3. Connect the earth cable from the LV-Distribution Board to the protective earth (PE) busbar in the UPS, located adjacent to the power terminals, as shown in Figures 3.10, 3.11 and 3.12.
4. The Kohler PW 5000/TP input supply can be wired for 'single feed' (standard) or 'dual feed' operation. Connect the input power cable coming from the LV-Distribution Board to the UPS input terminals following the 'single input feed' or 'dual input feed' given below.

#### Single Input Feed

1. Refer to the schematic drawing and connection table in Figure 3.8. Connect the UPS input supply cables to terminals 1L1, 1L2, 1L3 and 1N on the UPS main terminal block (see Figures 3.6 and 3.7). Ensure correct (clockwise) phase rotation.



**CAUTION:** The input Neutral cable must ALWAYS be connected.

2. Secure the cables to the fixing rail under the connection terminals.
3. 10kVA – 25kVA Models only: Ensure the bypass cables are connected to the correct terminals on the Filter Board (see Figure 3.6). These will be reconfigured by the commissioning engineer if necessary.
4. 25kVA – 50kVA 'C' cabinet models only: Ensure the single input feed links are fitted between the input and bypass supply terminal (see Figure 3.7).



### 3.7.3 Connecting the UPS output cables

1. To protect personnel during the UPS installation ensure that the connections are performed under the following conditions:
  - a) No input mains voltage is present.
  - b) All loads are shut down and isolated.
  - c) The UPS is shut down and voltage-free.
  - d) The UPS Maintenance Bypass Isolator IA1 is OFF (OPEN).
  - e) The UPS Parallel Isolator IA2 is OFF (OPEN).
2. Gain internal access to the UPS and remove the UPS terminal cover.
3. Connect the protective earth cable from the Load Distribution Board to the protective earth (PE) busbar in the UPS – located adjacent to the power terminals, as shown in Figures 3.10, 3.11 and 3.12.
4. Connect the UPS output supply cables to terminals 3L1, 3L2, 3L3 and 3N on the UPS main terminal block (see Figures 3.6 and 3.7). Ensure correct (clockwise) phase rotation.



**CAUTION:** The output Neutral cable must ALWAYS be connected.

5. Secure the cables to the fixing rail located below the UPS connection terminals.
6. Ensure the output cables are connected to the correct power terminals on the load distribution panel.

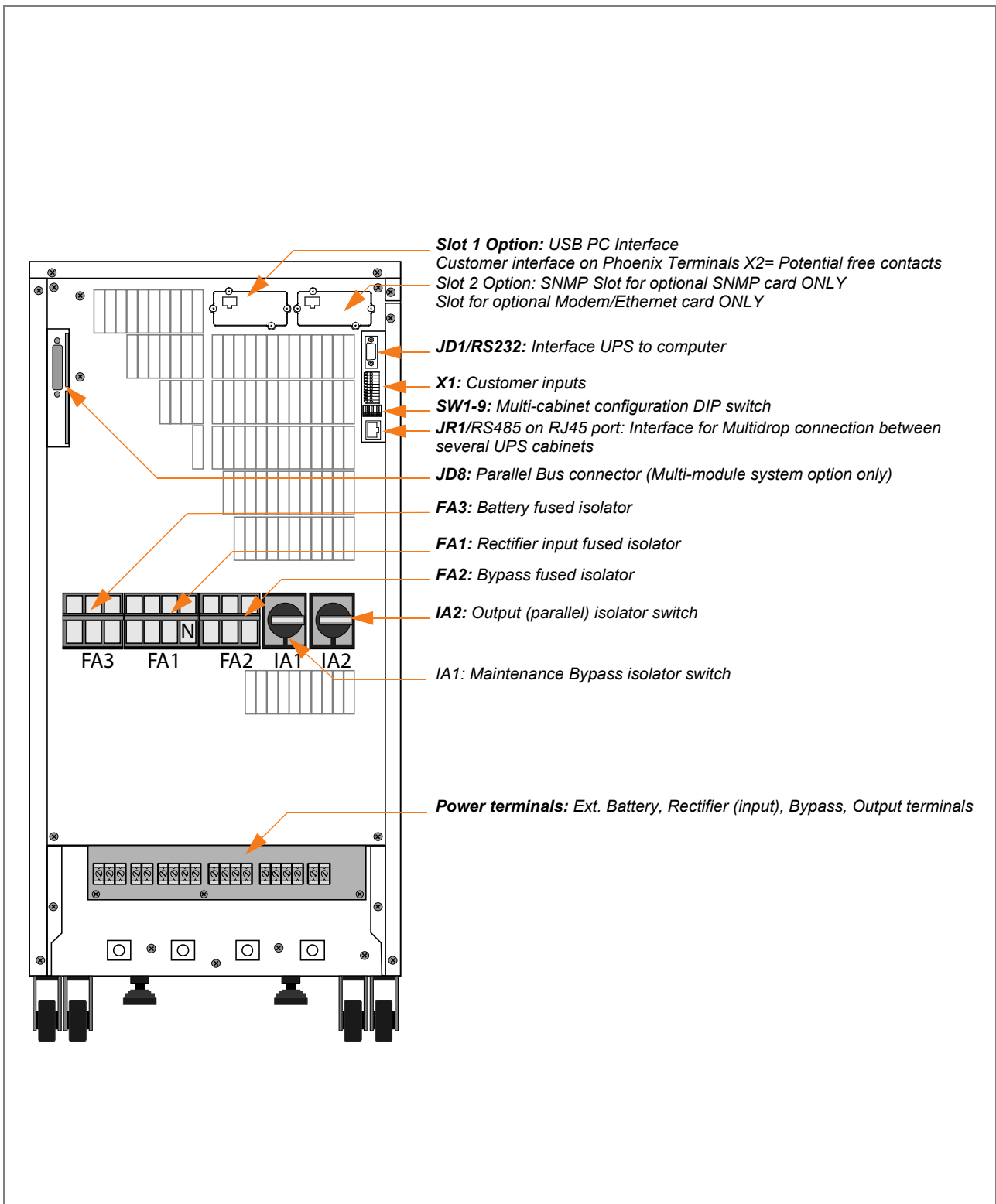

Figure 3.10 10 kVA–15 kVA Cabinet A connector details (rear view)

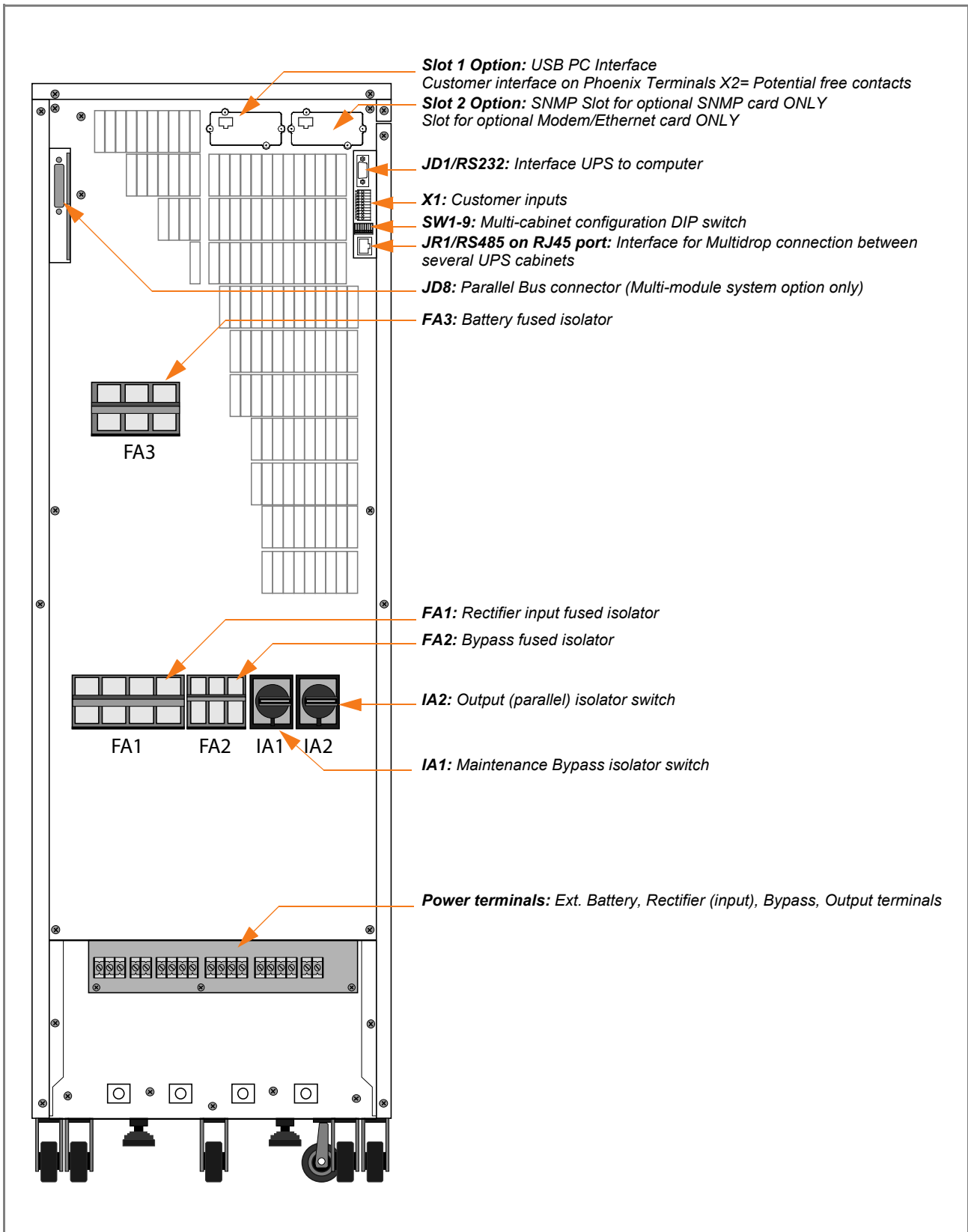

Figure 3.11 10 kVA - 25 kVA Cabinet B connector details (rear view)

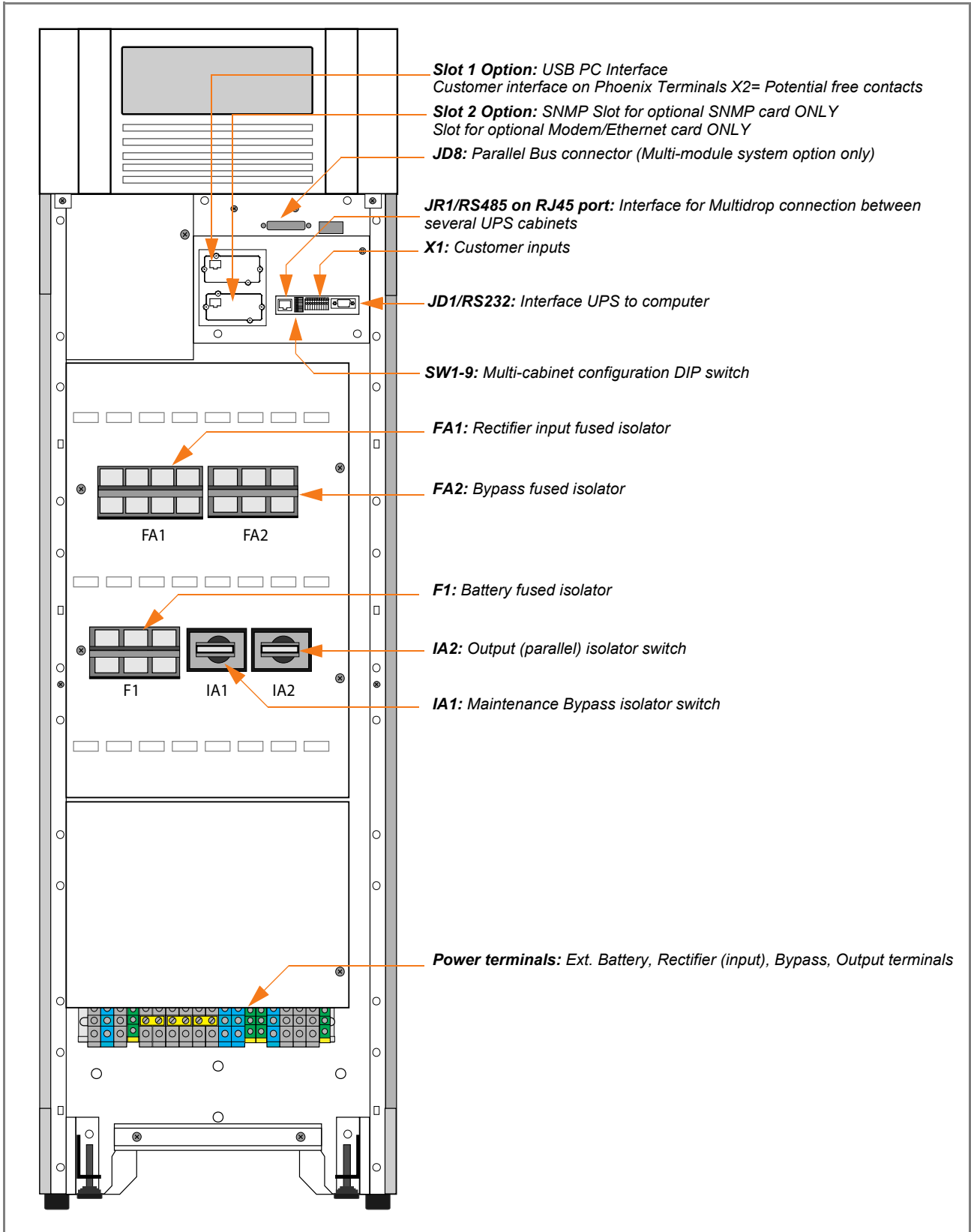

Figure 3.12 25 kVA - 50 kVA Cabinet C connector details (front view)

### 3.8 Battery connections



**WARNING:** The final assembly and connection of the battery units must be carried out by the commissioning engineer. Do not attempt to complete the battery wiring or close the battery isolators before this system has been commissioned

The cabinets are designed to house a number of 12V batteries of various capacities to provide a flexible, self-contained UPS system. Cabinets A & B can accept 7Ah or 9Ah batteries, while cabinet C can accept batteries of up to 28Ah. The batteries are connected in up to 48x12V strings and it is possible to connect 2 or 3 strings in parallel in Cabinets B & C, as shown in Figure 3.13, to enable a range of autonomy times to be achieved.

The final assembly and connection of the battery units will be carried out by the commissioning engineer.

#### 3.8.1 Remote battery enclosures

If the UPS internal batteries are unable to provide the required autonomy times they can be replaced by a larger battery system mounted in a separate, external battery cabinet.



**Key Point:** If an external battery system is used, the UPS internal batteries must be disconnected from the system. It is NOT possible to operate the internal and external batteries in parallel.

A range of matching battery enclosures are available, designed to suit individual site requirements. In each case the battery enclosure is fitted with a suitably rated fused isolator which is connected to the battery connection terminals inside the Kohler PW 5000/TP as shown in Figures 3.6 and 3.7.

*Note: DC fuses and cables are bespoke to the installation.*

#### 3.8.2 Connecting the external battery enclosure



**WARNING:** This procedure must be carried out by (or under the supervision of) the system commissioning engineer.

To protect personnel during battery installation the connections must be made under the following conditions:

- Mains voltage must be disconnected from the UPS
  - All loads must be disconnected
  - The UPS and the external battery terminals must be voltage-free
1. The UPS must be totally shut-down and power-free.  
Ensure the mains (and bypass) supply is isolated at the UPS input distribution board.
  2. Ensure that the MAINTENANCE BYPASS isolator (IA1) is open (OFF).
  3. Ensure that the battery isolator/fuses in the external battery cabinet (or racks) are open.
  4. Connect the protective earth cable (PE) between the UPS and external battery cabinet.
  5. Connect the corresponding +, N, - terminals between the UPS and external battery cabinet.
  6. The UPS battery isolator (FA3/F1) connections will require reconfiguring. This must be carried out by the commissioning engineer.

*Note: The DC and Battery fuses and cabling are bespoke to the installation.*

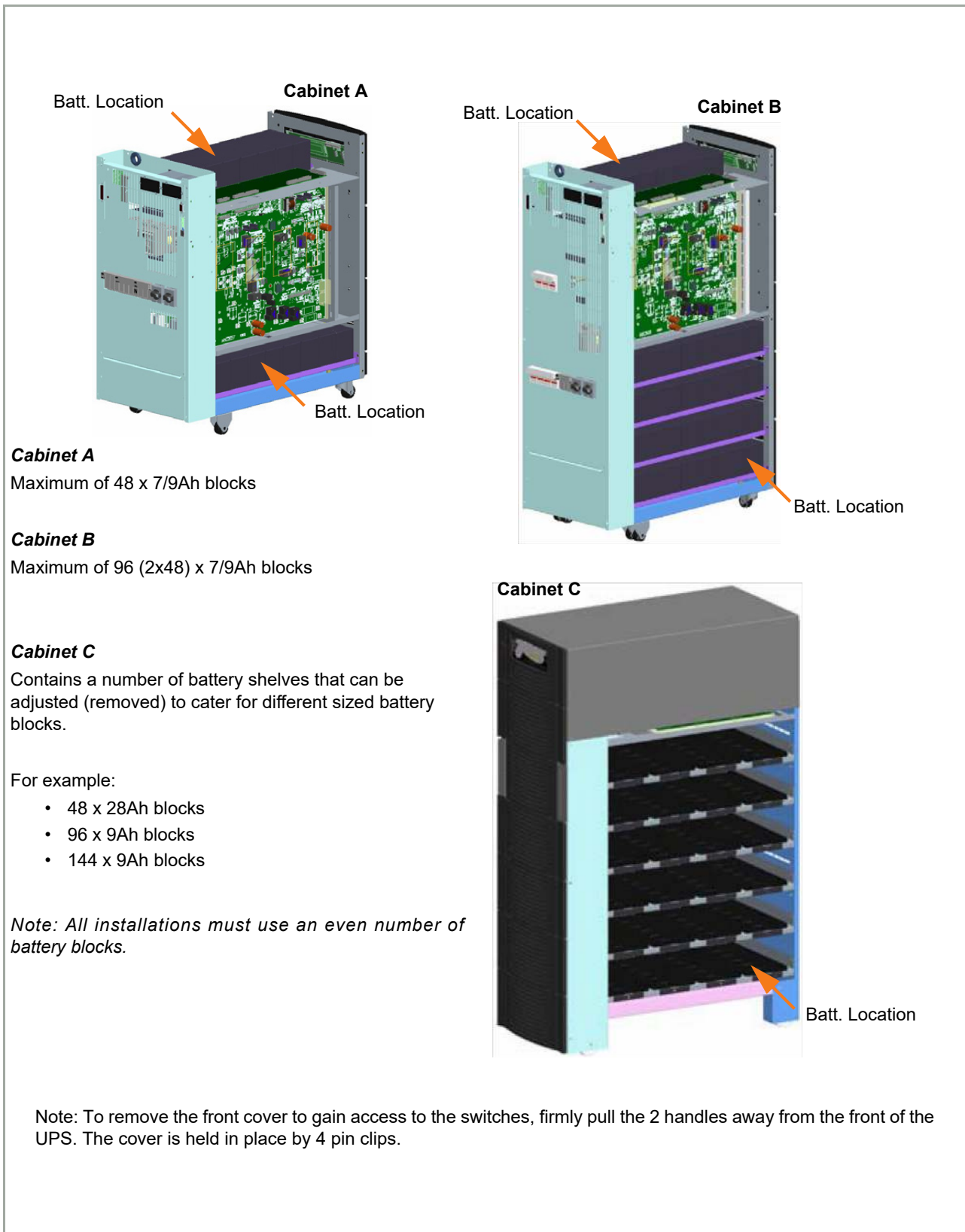

Figure 3.13 Internal battery locations

### 3.9 Multi-module control cabling and configuration



**WARNING:** When cabling the UPS cabinets, check with a voltmeter to confirm that each module power terminals are completely voltage free.

Check that the Maintenance Bypasses isolator (IA1), Parallel Isolator (IA2) and Bypass Line isolator (FA2) are open (OFF) on all cabinets.

#### 3.9.1 Connecting the parallel communication cables (Bus-lines)

In order to facilitate various parallel UPS control functions and operations (such as load sharing, frequency synchronisation, and load transfer) the paralleled UPS modules communicate with each other continuously by means of a communication Bus-line which takes the form of a signal cable connected between the modules.

The communication bus cables are daisy-chained between each module, as shown below in Figure 3.14. Once the cables are fitted, each module must be configured according to its position in the parallel system.

*Note: This will be carried out by the commissioning engineer.*

1. Connect the parallel control Bus-lines as follows:
2. Fit the Parallel Adaptor PCB (NW4019) to connector JD8 on all UPS-Cabinets (see Figures 3.10 and 3.12).
3. Set DIP Switch SW2-2 on each Parallel Adaptor according to the UPS cabinet's position in the parallel configuration (see Figure 3.14).
4. Connect a Bus-cable between PORT JD6 of UPS-Cabinet 1 Parallel Adaptor and PORT JD5 of UPS-Cabinet 2 Parallel Adaptor.
5. Connect a Bus-cable between PORT JD6 of UPS-Cabinet 2 Parallel Adaptor and PORT JD5 of UPS-Cabinet 3 Parallel Adaptor.
6. Continue with the above until a Bus-cable is connected to all modules.

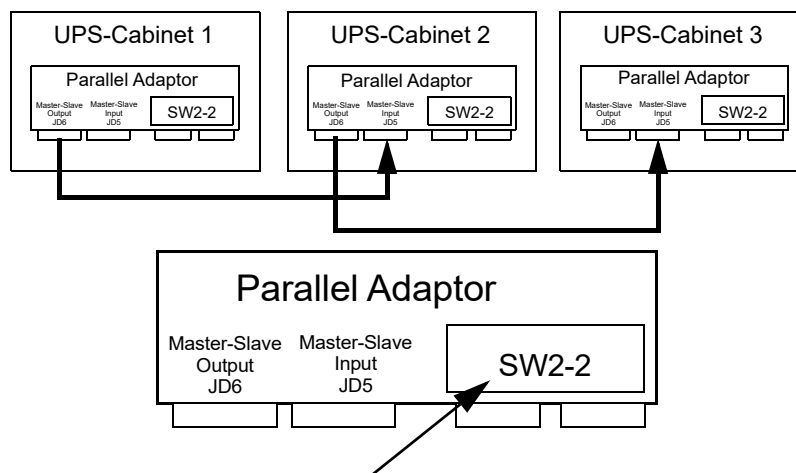

#### SW2-2 Configuration

|      | First Unit | Middle Unit | Last Unit | Single Unit |
|------|------------|-------------|-----------|-------------|
| SW 1 | OFF        | OFF         | ON        | ON          |
| SW 2 | ON         | OFF         | OFF       | ON          |

**Figure 3.14 Bus-lines connections (3 Modules shown)**

### 3.10 Module interfacing facilities

Each UPS is provided with communication port and a communication card, which provides system information:

| Standard Interface Facilities |  |
|-------------------------------|--|
| JD1                           | Smart Port – RS232 Sub D9/female interface (UPS system to computer).                   |
| X1                            | Customer input interface (Phoenix terminals).  |
| JR1                           | RS485 on RJ 45 port – Interface for Multidrop connection between several UPS cabinets. |

| Optional Facilities |  |
|---------------------|--|
| USB                 | PC Interface for remote signalling and automatic computer shutdown.  |
| X2                  | Customer output interface on Phoenix terminals (Potential free contacts): <ul style="list-style-type: none"> <li>• Common Alarm</li> <li>• Load On Bypass</li> <li>• Battery Low</li> <li>• Load on Inverter</li> <li>• Mains Failure</li> </ul> |
| SNMP                | Slot for optional SNMP card ONLY<br>For monitoring and integration in network management.  |

#### 3.10.1 JD1 Smart Port – Serial RS 232 and USB Port

The SMART PORT is an intelligent RS 232 serial port that allows the UPS to be connected to a computer. The connector is a standard D-Type, 9-pin, female, and the USB is a standard USB port.

When installed, the optional SMART PORT software, WAVEMON, allows the computer to monitor the mains voltage and the UPS-status continuously and display a message in the event of any UPS system changes.

Figure 3.15 and show the connection to a PC from the UPS for PC's with a 9 pin serial port and 25 pin serial port respectively.

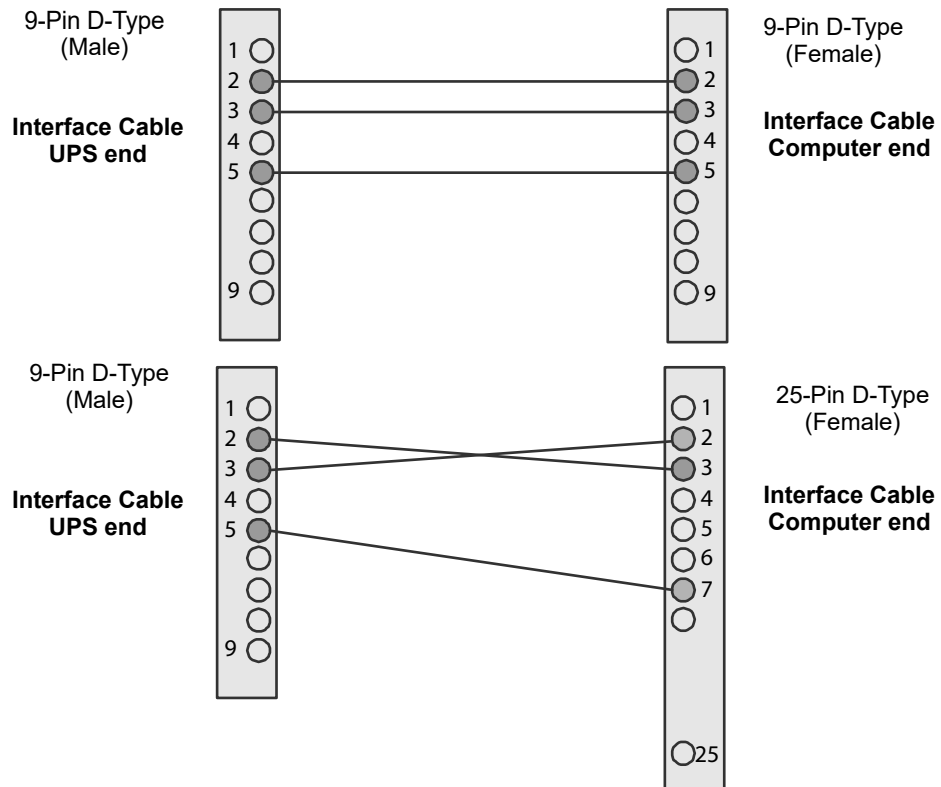

Figure 3.15 Connector Cable - PC Serial Port

### 3.10.2 X1 Dry Port (volt-free contacts)

All the Input and Output interfaces to X1 are connected to Phoenix terminals (cable 0.5mm<sup>2</sup>)

Connection of Remote Shut down facilities, Generator Operation, Customers specials (see also OPTIONS section).

| Terminal | Contact | Signal  | Function   |
|----------|---------|---------|--|
| X1/1     | In      | +12Vdc  | Customer IN 1 (default as Generator Operation)   |
| X1/2     | Gnd     | Gnd     | (NC = Generator ON)  |
| X1/3     | In      | +12Vdc  | Customer IN 2  |
| X1/4     | Gnd     | Gnd     | (Function on request, to be defined)   |
| X1/5     | In      | +3.3Vdc | Battery Temperature  |
| X1/6     | Gnd     | Gnd     | If connected, the battery charger current is temperature dependent                       |
| X1/7     | In      | +12Vdc  | Remote shutdown  |
| X1/8     | Gnd     | Gnd     | Do not remove the factory mounted bridge until an external remote shut down is connected |
| X1/9     | In      | +12Vdc  | 12Vdc source   |
| X1/10    | Gnd     | Gnd     | Max 200mA load   |

### 3.10.3 JR1 / RS485 INTERFACE FOR MULTIDROP

The Computer Interface JR1 located on the distribution part is an intelligent RS485 serial port that allows system information to be gained from all modules which are connected in parallel using the Multidrop connection kit. (For details see user manual Multidrop kit). The connector JR1 is a standard RJ45 port.

**3.10.4 X2 Dry Port – Optional Output Interfaces Terminal Block (X2)**

Provision of signals for the automatic and orderly shutdown of servers, AS400 or Automation building systems. All voltage free contacts are rated 60 VAC max. and 500 mA max.:

| Pin | Contact | Signal  | Function      |                             |
|-----|---------|---------|---------------|-----------------------------|
| 1   |         | Alarm   | MAINS_OK      | Mains Present               |
| 2   |         |         |               | Mains Failure               |
| 3   |         |         |               | Common                      |
| 4   |         | Message | LOAD_ON_INV   | Load On Inverter            |
| 5   |         |         |               | Load on Mains (BYPASS MODE) |
| 6   |         |         |               | Common                      |
| 7   |         | Alarm   | BATT_LOW      | Battery Low                 |
| 8   |         |         |               | Battery OK                  |
| 9   |         |         |               | Common                      |
| 10  |         | Message | LOAD_ON_MAINS | Load On Mains (BYPASS-MODE) |
| 11  |         |         |               | Load on Inverter            |
| 12  |         |         |               | Common                      |
| 13  |         | Alarm   | COMMON_ALARM  | Common Alarm                |
| 14  |         |         |               | No Alarm Condition          |
| 15  |         |         |               | Common                      |

**Figure 3.16 Dry Port (X2) Connections**

# 4 Operation

## 4.1 Commissioning

The Kohler PW 5000/TP UPS is a high quality electronic machine that must be commissioned by a fully trained and authorised Kohler Uninterruptible Power field service engineer before being put into use.

Commissioning the UPS involves connecting the UPS battery, checking the electrical installation and operating environment of the UPS, performing a controlled start-up and testing of the UPS system, and customer training.



**WARNING:** Any Kohler PW 5000/TP UPS system not commissioned by an Kohler Uninterruptible Power field service engineer must be considered an electrical hazard, and Kohler Uninterruptible Power accepts no responsibility for its safe operation or the safety of any personnel. Additionally, the manufacturer's warranty is immediately invalidated if the UPS is put into use before it has been correctly commissioned.

## 4.2 Control Panel

The user-friendly control panel is composed of three parts:

- Power Management Display (PMD)
- Mimic LED Indicators
- Operating keys

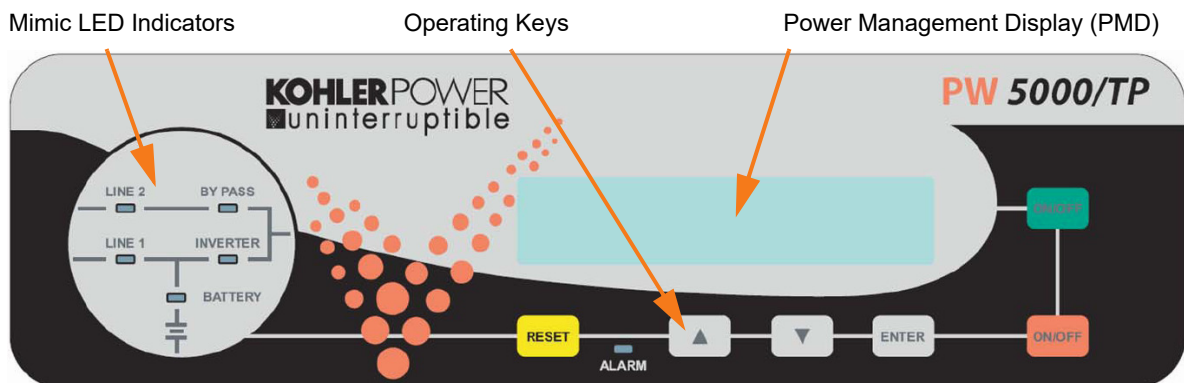

Figure 4.1 Control Panel

### 4.2.1 Power Management Display (PMD)

The 2 x 20 character LCD Power Management Display simplifies communication with the UPS and also provides UPS monitoring information (see paragraph 4.3).

The menu driven LCD enables the access to:

- The 'Event register'
- Monitoring the input and output voltage, current, frequency & power
- Monitoring battery run time
- Perform commands such as UPS start-up and shut-down, Load transfer from INVERTER to BYPASS and vice-versa
- Diagnostic (service mode only)
- Adjustments and testing (service mode only)



UPS module will shutdown and the module will effectively be disconnected from the parallel load bus; however, the load may or may-not transfer to the bypass supply in the remaining modules depending on the available module redundancy. To shut down all the modules in a parallel system you must press both ON/OFF buttons on every UPS cabinet!



**CAUTION:** If the ON/OFF buttons are operated (with no redundancy) while the UPS is not in Maintenance Bypass it will interrupt the load power supply.

## 4.3 Description of the LCD display

### 4.3.1 Status screens

| DESCRIPTION   | LCD-DISPLAY                                   |
|---|---|
| 1. Load is protected by UPS power supplied by inverter (normal operation).      | LOAD PROTECTED P01                            |
| 2. Load is not protected by UPS power –supplied by mains power (load on bypass) | LOAD NOT PROTECTED P01                        |
| 3. Load supply interrupted. UPS has been switched off by “ON/OFF” buttons.      | LOAD OFF SUPPLY FAILURE P01                   |
| 4. The UPS/module is not supplying load.<br>The output switch is open.          | LOAD DISCONNECTED P01<br>PARALLEL SWITCH OPEN |

On the right hand side of the LCD there is a 3 digit indicator which shows a module’s position in a multi-module system. The maximum number of modules that can be used in a parallel system is 20.

- S Stands for **Single** Module. The system consists only of one module.
- P01 Stands for **Parallel** Cabinet in a multi-module system and 01 stands for the first cabinet (**MASTER**) in the multi-module system.
- P02 Stands for **Parallel** Cabinet in a multi-module system and 02 stands for the second Cabinet (**SLAVE**) in the multi-module system (the number can range from 02 to 20 depending on the module’s position in the parallel system).

*Note: The definition of the cabinet position is set by the commissioning engineer.*

#### **Definition of the module position in a Single/Multi-module chain**

The position of a module in a multi-module configuration is set by DIP Switch SW1-9 (see paragraph 3.10 on page 26):

- **First** – First UPS module in the parallel configuration chain
- **Middle** – UPS module in the middle of the parallel configuration chain (there may be more than one ‘middle’ UPS)
- **Last** – UPS module is last in the parallel configuration chain.

If a UPS is operating as a Single module then it is seen as the First and Last in an imaginary chain.

### 4.3.2 Main menu screen

| DESCRIPTION   | LCD-DISPLAY                     |
|---|---------------------------------|
| 1. A log of the last 99 events is stored in the Power Management Display (see paragraph 4.3.3).                     | → EVENT LOG<br>MEASUREMENTS     |
| 2. Allows monitoring of voltages, power, frequencies, currents, autonomy etc (see paragraph 4.3.4)                  | → MEASUREMENTS<br>COMMANDS      |
| 3. Enables the commands "Load to inverter", "Load to bypass" and battery test to be executed (see paragraph 4.3.5). | → COMMANDS<br>SET-UP DATA       |
| 4. Allows the UPS personalized information (such as serial number) to be entered (see paragraph 4.3.6).             | → SET-UP DATA<br>SET-UP USER    |
| 5. Allows user to set up Date/Time, automatic battery test, etc. (see paragraph 4.3.7)                              | → SET-UP USER<br>SET-UP SERVICE |
| 6. Password-protected area for service engineer use only (see paragraph 4.3.8).                                     | → SET-UP SERVICE                |

### 4.3.3 Event log menu screen

| DESCRIPTION  | LCD-DISPLAY                          |
|--|--------------------------------------|
| 1. Logging Control; a log of the last 99 events is stored in the Power Management Display. | 01 05-10-08 14-38-56<br>LOAD TO INV. |
| 2. Every stored event is identified with a sequential number and time stamp.               | 02 05-10-08 14-38-59<br>LOAD TO BYP. |
| 3. By pressing ENTER the code of the event will be displayed.                              | 03 05-10-08 14-39-14<br>LOAD OFF     |

### 4.3.4 Measurements menu screen

| DESCRIPTION                                   | LCD-DISPLAY                          |
|---|--------------------------------------|
| 1. Battery Runtime                            | BATT. RUN TIME (MIN)<br>00h 00mm     |
| 2. UPS-Output Frequency                       | OUTPUT FREQUENCY (HZ)<br>50.00       |
| 3. Bypass Frequency.                          | BYPASS FREQUENCY (HZ)<br>50.00       |
| 4. Battery Voltage                            | BATTERY VOLTAGE (V)<br>+0.0 - 0.0    |
| 5. Battery Charger Current                    | BATT. CHARGE CUR. (A)<br>+ 0.0 - 0.0 |
| 6. Battery Discharge Current.                 | DISCHARGE CURRENT (A)<br>00.00       |
| 7. Rectifier Input Voltage (all three phases) | RECTIFIER VOLTAGE (V)<br>230 230 230 |
| 8. Bypass Input Voltage (all three phases)    | BYPASS VOLTAGE (V)<br>230 230 230    |

| DESCRIPTION                                  | LCD-DISPLAY                                |
|--|--|
| 9. Output Voltage (all three phases)         | OUTPUT VOLTAGE (V)<br>230 230 230          |
| 10. Output Current (all three phases)        | OUTPUT CURRENT (A)<br>00.00 00.00 00.00    |
| 11. Active Output Power (all three phases)   | ACTIVE POWER (KW)<br>00.00 00.00 00.00     |
| 12. Reactive Output Power (all three phases) | REACTIVE POWER (kVAR)<br>00.00 00.00 00.00 |
| 13. Apparent Output Power (all three phases) | APPARENT POWER (KVA)<br>00.00 00.00 00.00  |
| 14. Output Power (all three phases)          | OUTPUT POWER (%)<br>00.00 00.00 00.00      |
| 15. Battery capacity                         | BATT. CAPACITY (%)<br>00                   |

#### 4.3.5 Commands menu screen

| DESCRIPTION                  | LCD-DISPLAY                            |
|------------------------------|--|
| 1. Transfer Load to inverter | → LOAD TO INVERTER<br>LOAD TO BYPASS   |
| 2. Transfer Load to bypass.  | → LOAD TO BYPASS<br>PERFORM BATT. TEST |
| 3. Battery Test              | → PERFORM BATT. TEST                   |

#### 4.3.6 UPS Data menu screen

| DESCRIPTION   | LCD-DISPLAY  |
|---|--|
| 1. These general UPS Data are installed at the manufacturing plant. | UPS SERIAL NUMBER<br>nn-nnnnnn                                     |
| 2. Manufacturing date   | DATE OF MANUFACTURE<br>15-03-11                                    |
| 3. EPROM Version  | EPROM VERSION<br>V-000   |
| 4. Actual Date and Time   | DATE                      TIME<br>dd-mm-yyyy              hh:mm:ss |

### 4.3.7 Set-up User menu screen

| DESCRIPTION                      | LCD-DISPLAY  |
|----------------------------------|--|
| 1. Set-up language               | → SET LANGUAGE<br>SET DATE AND TIME<br>ENGLISH<br>FRANCAIS<br>DEUTCH<br>DUTCH<br>SPANISH<br>POLISH<br>PORTOGUESE             |
| 2. Set-up Date and Time          | → SET-UP DATE/TIME<br>SET-UP BATT. TEST<br>DD-MM-YY HH-MM-SS   |
| 3. Set-up battery test           | → SET-UP BATT. TEST<br>SET-UP GEN-SET OPER.<br>DAY OF MONTH<br>(1-31)<br>HOUR OF DAY<br>(0-23)<br>REPETITIVE (Y/N)<br>YES/NO |
| 4. Set-up operation with Gen-Set | → SET GENERATOR OP.<br>BATT. CHARGE LOCK<br>YES/NO<br>BYPASS LOCK<br>YES/NO  |

### 4.3.8 Set-Up Service menu screen

| DESCRIPTION  | LCD-DISPLAY                  |
|--|------------------------------|
| 1. This password-protected Menu is reserved for authorized service engineers. It is not to be used by End-Users. | → SET-UP SERVICE<br>PASSWORD |
| 2. Type in password  | → PASSWORD*                  |



**Key Point:** It is essential to enter the password.

From within the Set-up Service menu a service engineer can adjust the UPS voltages, frequencies, currents, power and autonomies, together with setting up:

- UPS Rated Power
- Module configuration S, P01, P02...
- Single (standard) or Dual input feed
- Frequency-converter, 50/60Hz and 60/50Hz
- Synchronisation window (2-4%)

## 4.4 Operating Modes

### 4.4.1 On-Line (Inverter) mode

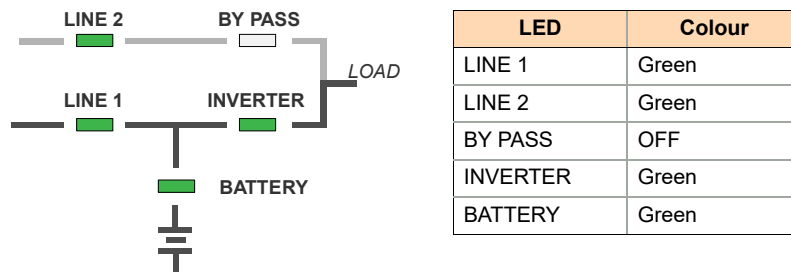
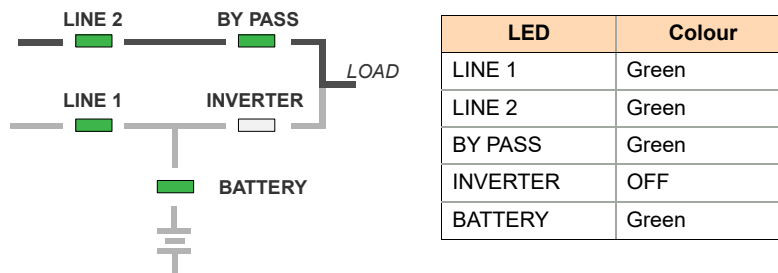

**Figure 4.2 On-Line Mode**

When the UPS is operating in the On-Line mode the load is supplied through the LINE 1 (RECTIFIER) and INVERTER. This mode provides the highest degree of protection, especially in the event of a mains disturbance or failure, and is always recommended if the critical loads (computer systems) will not tolerate any (even very brief) interruption of the supply.

In the unlikely event of an inverter fault or overload condition the UPS will transfer the load automatically, and without interruption, to the static bypass supply (transfer time = 0).

### 4.4.2 Bypass (Line-Interactive) mode



**Figure 4.3 Line-Interactive (Bypass Mode)**

In the Bypass (Line-Interactive) mode the load is supplied from the bypass mains (LINE 2) and the static BYPASS. In the event of a mains failure the load is automatically transferred to the inverter within 3 to 5 msec – this is valid for single and parallel module systems. The battery charger remains active in this mode.

Although this mode of operation offers greater efficiency than the On-Line mode, it is recommended only if the loads can tolerate interruptions of 3 to 5 ms – which is the transfer time taken to change from Bypass mode to On-Line mode.



**WARNING:** The On-Line mode must always be used to provide maximum load protection.

**4.4.3 Maintenance Bypass Mode**

**Maintenance bypass operation in a ‘single module’ and ‘1+1 redundant’ system**

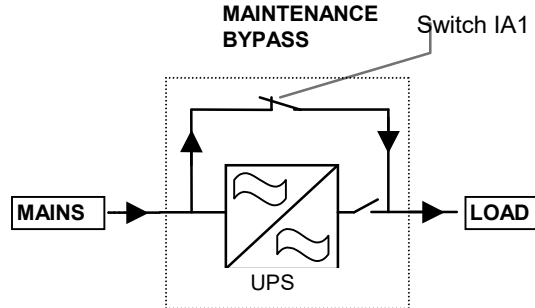

**Figure 4.4 Maintenance Bypass Mode**

Each module is fitted with a Maintenance Bypass switch (IA1) which, when closed, connects the UPS module output terminals directly to the UPS bypass mains supply. In a ‘single module’ or ‘1+1 redundant’ installation, this facility enables a UPS module to be shut down for maintenance or repair whilst maintaining the load on the raw (unprotected) maintenance bypass supply.

*Note: When switching to this mode BOTH the UPS modules in a ‘1+1 redundant’ system must first be selected to the Bypass mode.*

The Maintenance Bypass mode is effected by means of the IA1 BYPASS SWITCH:

| Switch IA1 | Effect   |
|------------|--|
| ON         | Maintenance Bypass-Switch Closed (Load on bypass mains)<br>LCD-indication: MAINTENANCE BYP CLOSED<br>LED Indicators will indicate as shown in table below          |
| OFF        | Bypass-Switch Open – Normal operating condition (Load on inverter)<br>LCD-indication MAINTENANCE BYP OPEN<br>LED Indicators will indicate as shown in table below. |

| LED Indicator | ON    | OFF   |
|---------------|-------|-------|
| LINE 1        | Green | Green |
| LINE 2        | Green | Green |
| BYPASS        | Green | OFF   |
| INVERTER      | RED   | ON    |
| BATTERY       | Green | Green |



**CAUTION:** *If the UPS is operating in the Maintenance Bypass mode the load will not be protected in the event of a mains failure. It is therefore strongly recommended to switch over to the on-line mode or bypass mode as soon as possible.*

**Maintenance bypass in a multi-module parallel system**

In a ‘multi-module’ parallel UPS system the maintenance bypass switch (IA1) in an individual UPS module is not rated to carry the full system load and should never be closed. In this type of system the maintenance bypass circuit is provided by a single external circuit breaker that wraps around the entire UPS system. For reasons of safety, and sustaining the load

during switch-over, the external maintenance bypass circuit breaker is normally interlocked with the UPS input mains supply circuit breaker at the mains distribution panel.



**WARNING: DO NOT CLOSE THE MAINTENANCE BYPASS SWITCH (IA1) ON A UPS MODULE IN A MULTI-MODULE PARALLEL SYSTEM. DOING SO COULD CAUSE PERSONAL INJURY, EQUIPMENT DAMAGE OR INTERRUPT THE LOAD SUPPLY.**

#### 4.4.4 Multi-module configuration concept

Up to 20 Kohler PW 5000/TP UPS modules can be connected in parallel to provide increased power capacity or redundancy operation.

*Note: Although the UPS single/multi configuration can be modified in the field it is generally specified on ordering so that the module can be configured and fully tested in the factory prior to despatch.*

When operating in a parallel system, the Kohler PW 5000/TP configuration presents a decentralised bypass architecture – i.e. each UPS module is provided with its own static bypass. Ribbon cables are connected between adjacent modules to enable ‘system level’ control of load transfer, frequency synchronisation, load sharing etc.

Within the parallel control system there is always one ‘master’ module with the remaining modules acting as ‘slaves’, and if at any time the master goes faulty the next module in the chain (a former slave module) will immediately take over the role of master, and the former master will switch off. Master/slave configuration is achieved through selector switches located in each cabinet and is set-up during commissioning (see paragraph 3.10).

#### Parallel Isolator (IA2)

Every UPS-module is provided with an output parallel isolator (IA2) which can be used to take the UPS off-line if required. When IA2 is open it isolates the module’s output from the parallel bus (and therefore from the load) and there is no power being provided by the inverter.

| IA2 Switch  | EFFECT   |
|-------------|--|
| CLOSED (ON) | Normal operation (Load power is being supplied by the UPS)   |
| OPEN (OFF)  | UPS module is isolated from the Parallel Load Bus for maintenance or module replacement (UPS-Module is not supplying load power) |

*Note: In a redundant module system one (or more) module(s) is permitted to be taken off-line without affecting the remaining, on-line modules. If the number of off-line modules exceeds the system redundancy the load is transferred to bypass.*

#### ON/OFF Start-up and shutdown buttons

The ON/OFF buttons on the Operator Control Panel are used to Start and Stop the UPS module. Once again, when the module is part of a redundant module system, stopping one module using these buttons will shut down the affected module only, and will not cause the remaining modules to shutdown or necessarily transfer the load to bypass unless the number of shut down modules exceeds the system redundancy.

#### Load transfer commands

The load is normally transferred between the inverter and bypass supply via the control panel commands menu. In a parallel system, if you activate the LOAD TO BYPASS command on any module then all the modules will simultaneously transfer the load to their bypass supply. Conversely, when operating ON BYPASS if you perform the command LOAD TO INVERTER on any module *all the UPS modules* will simultaneously transfer the load to their inverters (provided a sufficient number of modules are operating to satisfy the system redundancy requirements).

## 4.5 Operating Instructions

Under normal operating conditions all the UPS modules in a multi-module system are running, and operating in the 'On Line' (On Inverter) mode.

The following procedures are provided in this section:

How to transfer the load to the Maintenance Bypass and shut down the UPS system for maintenance purposes – (see paragraph 4.5.1).

How to start up the UPS system and transfer the load from the Maintenance Bypass to the inverters ('On Line' mode) – (see paragraph 4.5.2).

How to shut down the entire UPS system – (see paragraph 4.5.3).

How to stop and start one module in a redundant multi-module system – (see paragraph 4.5.4).

### 4.5.1 Transfer to Maintenance Bypass Mode

If needed, to perform service or maintenance, it is possible to transfer the load to Maintenance Bypass Mode and power down the UPS module(s) whilst leaving the load connected to the raw bypass mains supply.



**WARNING:** Before you close the Maintenance Bypass isolator ensure that the UPS is operating in the Bypass Mode.

All the operations in this section must be performed by authorised and trained personnel.

This procedure describes the sequence of operations to transfer the load to the Maintenance Bypass supply and then shut down, and isolate, the UPS Module(s).

Prior to commencing this procedure, check and confirm the following UPS system status (on all cabinets in a multi-module system):

- The mimic panel LED indications should be as per the following table (on all cabinets in a multi-module system):

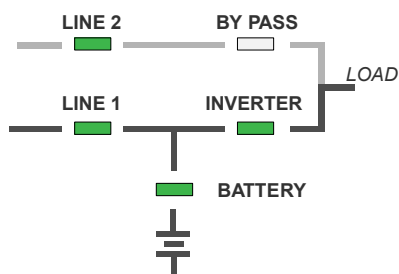

| LED      | Colour |
|----------|--------|
| LINE 1   | Green  |
| LINE 2   | Green  |
| BY PASS  | OFF    |
| INVERTER | Green  |
| BATTERY  | Green  |

- The LCD panel should display LOAD PROTECTED. If anything other than LOAD PROTECTED is displayed then press the RESET button, and if LOAD PROTECTED is still not displayed there is a problem with the UPS – seek assistance!

#### Transferring the UPS to 'Bypass' mode:

- On any one of the UPS module's mimic panel press the ENTER key once to access the menu system.
- Using the UP/DOWN keys, move the cursor so that it is adjacent to COMMANDS and then press the ENTER key.
- Using the UP/DOWN keys, move the cursor so that it is adjacent to LOAD TO BYPASS and then press the ENTER key.
  - The UPS system will transfer the load to static bypass.
- On all modules in a multi module system check and confirm that:
  - The INVERTER LED has extinguished.
  - The BYPASS LED is green.
  - The LCD displays LOAD NOT PROTECTED.

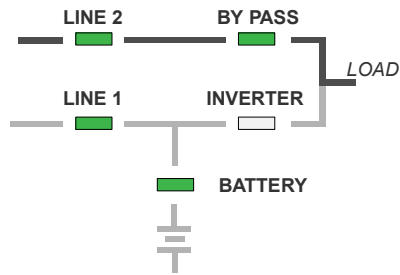

| LED      | Colour |
|----------|--------|
| LINE 1   | Green  |
| LINE 2   | Green  |
| BY PASS  | Green  |
| INVERTER | OFF    |
| BATTERY  | Green  |

**Closing the Maintenance Bypass switch:**

*Note: The following instructions are for a 'single module' or '1+1 redundant' system only. In a 'multi-module parallel' system, close the external maintenance bypass circuit breaker in accordance with local instructions (see paragraph 4.4.3 on page 36).*

5. Close the Maintenance Bypass switch IA1.
6. On all modules check and confirm that:
  - a) The INVERTER LED has turned to red.
  - b) The BYPASS LED is green.
  - c) The LCD displays MANUAL BYP IS CLOSED.

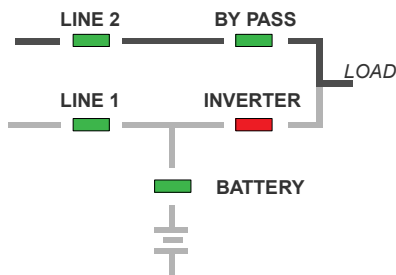

| LED      | Colour |
|----------|--------|
| LINE 1   | Green  |
| LINE 2   | Green  |
| BY PASS  | Green  |
| INVERTER | RED    |
| BATTERY  | Green  |

**Powering down a UPS module:**

When the load is connected to the Maintenance Bypass supply, as described above, the UPS module(s) can be powered down (for example, if required for maintenance/testing) using the following procedure:

*Note: Carry out the following procedure on each module in a parallel system.*

7. On the UPS control panel simultaneously press both ON/OFF buttons.
  - a) The LCD panel will indicate: LOAD OFF , SUPPLY FAILURE.
8. Open the battery fuse/isolator.
  - a) Open FA3/F1 if using internal batteries.
  - b) If using external batteries open the battery fuses/isolator on the associated battery cabinet/rack.
9. On the UPS module open the module's Parallel Isolator (IA2).

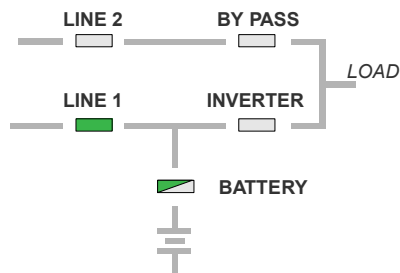

| LED      | Colour         |
|----------|----------------|
| LINE 1   | Green          |
| LINE 2   | Off            |
| BY PASS  | Off            |
| INVERTER | Off            |
| BATTERY  | Green Flashing |

10. Open the Bypass Line fuse holder FA2 and the Rectifier Line fuse holder FA1.



**WARNING:** The UPS module is still live at its input and output power terminals due to the activation of Maintenance Bypass circuit.

**WARNING:** Allow 10 minutes for the internal DC capacitors to discharge before touching any UPS internal components.

**WARNING:** The load is now supplied from the bypass mains and is not protected against power failure.

#### 4.5.2 Starting the UPS system from the Maintenance Bypass

This procedure describes the sequence of operations necessary to power up the UPS module(s) whilst the load is connected to the Maintenance Bypass supply, and then transfer the load to the UPS Inverter(s) ('On-Line' mode).



**WARNING:** All the operations in this section must be performed by authorised and trained personnel.

Prior to powering-up the system, check and confirm the UPS system status:

- The load is supplied via the Maintenance Bypass switch (in all modules)
- The UPS module(s) are powered down

#### Powering up the UPS Module(s):

In a multi-module system perform each of the steps in turn on every module.

1. On the UPS module close the Bypass Line fuse holder FA2 and the Rectifier Line fuse holder FA1 if they are open.
2. Close the battery fuse FA3/F1 (if using internal batteries), or the battery fuse/isolator on the external battery cabinet/rack (where used).
  - a) The UPS mimic panel LINE 1 LED will be permanent green.
  - b) The BATTERY LED will be flashing green.
  - c) The LCD display will indicate LOAD OFF, SUPPLY FAILURE.

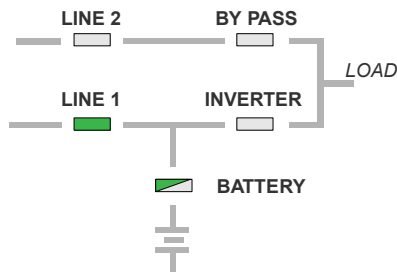

| LED      | Colour         |
|----------|----------------|
| LINE 1   | Green          |
| LINE 2   | Off            |
| BY PASS  | Off            |
| INVERTER | Off            |
| BATTERY  | Green Flashing |

3. Close the Parallel Isolator switch (IA2) and check that the PARALLEL SW CLOSED message is shown on the LCD display.
4. On the UPS mimic panel press and release both ON/OFF buttons simultaneously and wait approximately 60 seconds.
  - a) The UPS module will begin to power up.
  - a) Initially LINE 2 LED will be red, then change to green.
  - a) At this stage the LCD display will indicate LOAD NOT PROTECTED and the module mimic LED indications should be as follows:

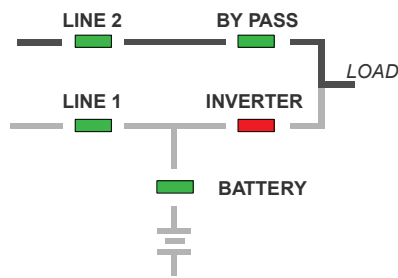

| LED      | Colour |
|----------|--------|
| LINE 1   | Green  |
| LINE 2   | Green  |
| BY PASS  | Green  |
| INVERTER | RED    |
| BATTERY  | Green  |

5. When powering up a multi-module system ensure that ALL the modules are in the state shown above before continuing with this procedure.

**Transferring to the UPS from the Maintenance Bypass:**

*Note: The following instructions are for a 'single module' or '1+1 redundant' system only. In a 'multi-module parallel' system, open the external maintenance bypass circuit breaker in accordance with local instructions (see paragraph 4.4.3 on page 36).*

6. Ensure that the BYPASS LED is green (on all modules).
7. Open the Maintenance Bypass switch (IA1) (on all modules).
  - a) The LCD panels will display MANUAL BYPASS OPEN.
  - b) The INVERTER LED will be extinguished.
  - c) An audible alarm will sound.

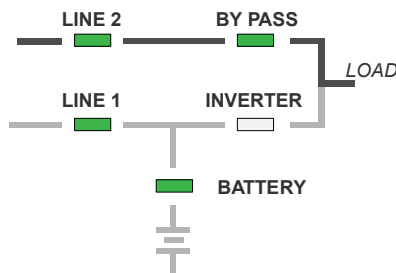

| LED      | Colour |
|----------|--------|
| LINE 1   | Green  |
| LINE 2   | Green  |
| BY PASS  | Green  |
| INVERTER | Off    |
| BATTERY  | Green  |

8. Press the RESET button to cancel the audible alarm (on all modules).
  - a) The LCD display(s) will now indicate LOAD NOT PROTECTED.

**Transferring the load to the inverter:**

9. On the Control Panel (of any one module in a multi-module system):
  - a) Press the UP key once to access the menu system.
  - b) Use the UP/DOWN keys to move the cursor so that it is adjacent to COMMANDS and then press the ENTER key.
  - c) Use the UP/DOWN keys move the cursor so that it is adjacent to LOAD TO INVERTER and then press the ENTER key.
10. The UPS system will transfer the load to Inverter (on all modules in a multi-module system).
  - a) The LCD display(s) will now indicate LOAD PROTECTED.
  - b) Check and confirm that the LED display(s) are as shown below:

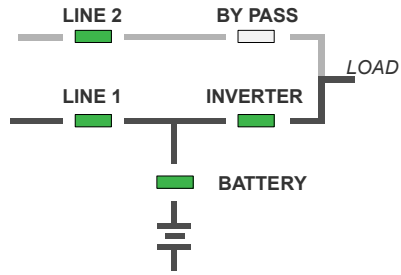

| LED      | Colour |
|----------|--------|
| LINE 1   | Green  |
| LINE 2   | Green  |
| BY PASS  | Off    |
| INVERTER | Green  |
| BATTERY  | Green  |

11. The UPS is now operating in 'On-Line' mode. The load is protected and supplied by inverter power.

### 4.5.3 Complete system shutdown

The UPS system may be shutdown completely if the load does not need input power for an extended period of time. Use this procedure to turn off the load power and shutdown the entire UPS system.



**WARNING:** All the operations in this section must be performed by authorised and trained personnel.



**CAUTION:** This procedure will totally disconnect load power. Ensure that it is safe to lose power to all the loads connected to the UPS system before you begin this process.

1. Isolate all load equipment connected to the output of the UPS system by opening the fused isolators or circuit breakers in the UPS output load distribution board.



**WARNING:** Perform the following steps only after the load has been fully isolated.

2. Verify that the loads are powered down. Then carry out the following actions on every module in a multi-module system.
3. On the UPS control panel simultaneously press both ON/OFF buttons.
  - a) The LCD panel will indicate: LOAD OFF , SUPPLY FAILURE.
4. Open the battery fuse/isolator.
  - a) Open FA3/F1 if using internal batteries.
  - b) If using external batteries open the battery fuses/isolator on the associated battery cabinet/rack.
5. Open the module's Parallel Isolator switch (IA2).

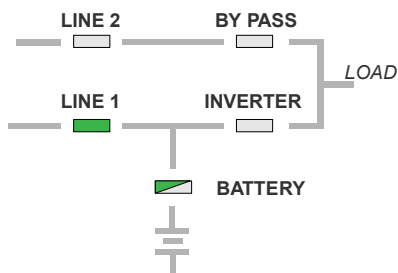

| LED      | Colour         |
|----------|----------------|
| LINE 1   | Green          |
| LINE 2   | Off            |
| BY PASS  | Off            |
| INVERTER | Off            |
| BATTERY  | Green Flashing |

6. Open the Bypass Line fuse holder FA2 and the Rectifier Line fuse holder FA1.
7. Open the UPS Input and Bypass supply fused isolators (or breakers) in the building power distribution panel.
8. The UPS is now voltage free.



**WARNING:** Allow 10 minutes for the internal DC capacitors to discharge before touching the UPS internal components.

#### 4.5.4 Individual module start/stop procedure

If a multi-module system is designed with built-in redundancy it is possible to stop and start one module without affecting the operational status of the overall system – e.g. one module can be taken off-line for servicing whilst the remaining modules maintain the protected load supply.



**WARNING:** All the operations in this section must be performed by authorised and trained personnel.

##### Module start-up:

Use this procedure to start a module and connect it to a multi-module system.

This procedure assumes the following initial conditions:

- UPS input isolators are open on the building's LV supply switchboard
  - The fused battery isolator(s) are open
  - In the UPS cabinet, the fused isolators FA1, FA2 and the parallel isolator (IA2) are open
1. In the UPS cabinet, close the Input supply and Bypass supply fused isolators FA1, FA2 and the Parallel Isolator IA2.
  2. Close the UPS input supply isolator at the LV switchboard.
    - a) The LINE 1 indicator will illuminate green.
    - b) The LCD display will indicate LOAD OFF SUPPLY FAILURE.

*Note: If necessary press the RESET button to obtain this display indication.*

3. Close the battery fuse/isolator.
  - a) Close FA3/F1 if using internal batteries.
  - b) If using external batteries close the battery fuses/isolator on the associated battery cabinet/rack.
4. Simultaneously press the two ON/OFF push buttons on the UPS control panel.
  - a) The UPS will run through an automated start-up sequence accompanied by the following indications:
    - LINE 2 LED lights red then changes to green.
    - INVERTER LED lights green.
    - BATTERY LED lights green (constant).
  - b) LCD displays the LOAD PROTECTED message.

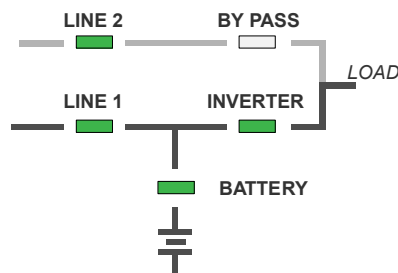

| LED      | Colour |
|----------|--------|
| LINE 1   | Green  |
| LINE 2   | Green  |
| BY PASS  | Off    |
| INVERTER | Green  |
| BATTERY  | Green  |

5. The UPS module is now On Line and connected to the parallel system.



# 5 Maintenance

## 5.1 Introduction



**WARNING:** All the operations described in this chapter must be performed by authorised electricians or otherwise qualified personnel.

## 5.2 System calibration

To ensure optimum UPS operation and continuous, efficient protection of the connected load, it is recommended that the system's operating parameters are checked every six months and recalibrated where necessary.

The batteries should also be checked every six months, depending on the ambient temperature.

## 5.3 User responsibilities

There are no user-serviceable parts contained within the UPS so the maintenance requirements of the user are minimal. To maximise the useful working life and reliability of the UPS and its batteries, the environment in which the UPS operates should be kept cool and dust free.

## 5.4 Routine maintenance

It is essential that the UPS system and batteries receive regular preventative maintenance inspection to maximise both the useful working life and the reliability of the UPS system. When the UPS is commissioned, the commissioning field service engineer will attach a service record book to the front of the UPS which will be used to log the full service history of the UPS.

Preventative maintenance inspections involve working inside the UPS which contains hazardous AC and DC voltages.



**WARNING:** Only Kohler Uninterruptible Power trained and authorised field service engineers are fully aware of all of the hazardous areas within the UPS.

During a preventative maintenance inspection the field service engineer will carry out the following checks:

- Site/environment conditions
- Integrity of electrical installation
- Cooling airflow
- Rectifier operation and calibration
- Inverter operation and calibration
- Static switch operation
- Battery status
- Load characteristics
- Integrity of alarm and monitoring systems
- Operation of all installed options

Preventative maintenance inspections form an integral part of all Extended Warranty Agreements (maintenance contracts) offered by Kohler Uninterruptible Power

For further details on Extended Warranty Agreements see Section 2 of this manual.

## 5.5 Battery Testing

The battery test takes approximately 3 minutes and should be performed only if:

- There are no alarm conditions
- The battery is fully charged

The battery test procedure can be performed from the UPS front panel and can be carried out independently of the operating mode (Off-line or On-line) and whether or not the load is connected.

# 6 Troubleshooting

## 6.1 Alarms

In the event of an alarm condition the red ALARM LED-indicator will illuminate on the operator control panel and the audible alarm will sound.

In this case proceed as follows:

1. Silence the audible alarm by pressing the RESET button.
2. Identify the cause of the alarm condition by viewing the events register in the main menu (*See paragraph 4.3.3*).
3. In case of doubt please contact Kohler Uninterruptible Power

Fault identification and rectification information is given on the following pages.

### IMPORTANT NOTE

Certain alarm conditions may 'latch-on' even after the cause of the alarm is no longer present. For example, if there is a brief mains failure during unattended operation the MAINS RECT FAULT alarm will activate and it may still indicate a fault condition even after the mains supply has returned to normal.

If any of the following alarms appear, the first action to take is to attempt to RESET it.

- MAINS RECT FAULT
- MAINS BYP FAULT
- BYPASS IS OK
- BYPASS IS NOT OK

If the alarm resets then it was probably caused by a transient condition and is no longer present; the UPS responded correctly and no further action is required. However, if it is not possible to reset the alarm, investigative action is necessary which may require assistance from the UPS Service department.

## 6.2 Menu, Commands, Event Log, Measurements,

A detailed description of the Menu, Commands, Event Log and Measurements that can be operated and displayed on the LCD can be found in Section 4.



### 6.3 Contacting Service

Kohler Uninterruptible Power has a service department dedicated to providing routine maintenance and emergency service cover for your UPS.

We recommend that your UPS is protected by an Extended Warranty Agreement. These agreements assist us in caring for your UPS correctly, ensuring that it is well maintained and attended to promptly should any problems occur.

If you have any queries regarding your UPS please contact us.

Kohler Uninterruptible Power  
7 Jurong Pier Road  
Singapore  
619159

---

Tel: +65 6302 0702

---

Email: [serviceups.sg@kohler.com](mailto:serviceups.sg@kohler.com)

# 7 Options

## 7.1 Introduction

The Kohler PW 5000/TP UPS has the following available options:

- Remote Emergency Stop facilities
- Generator On facilities
- Temperature sensor for temperature-dependant battery charging
- Software for automatic shutdown and monitoring
- SNMP Card for network management and remote monitoring
- Modem/Ethernet interface for PowerREPORTER™ management software

## 7.2 Remote Emergency Stop facilities

The remote emergency stop facility comprises a normally-closed contact, connected to terminal port X1/7 and X1/8 on the communications board, which opens to operate the emergency stop sequence.

*Note: Usually the remote emergency stop function is disabled, and it should be activated by a hardware code on the SETUP SERVICE menu. Please contact your distributor to enable this operation.*

To allow removal, maintenance or testing of any remote emergency stop facility without disturbing the normal operation of the UPS, it is recommended that a terminal block, with linking facilities, is installed between the UPS and the remote emergency stop button.

1. Use a screened cable with 1 pair (section of wires 0.6 mm<sup>2</sup>) and maximum length of 100 m.
2. Connect the cable as shown in Figure 7.1.

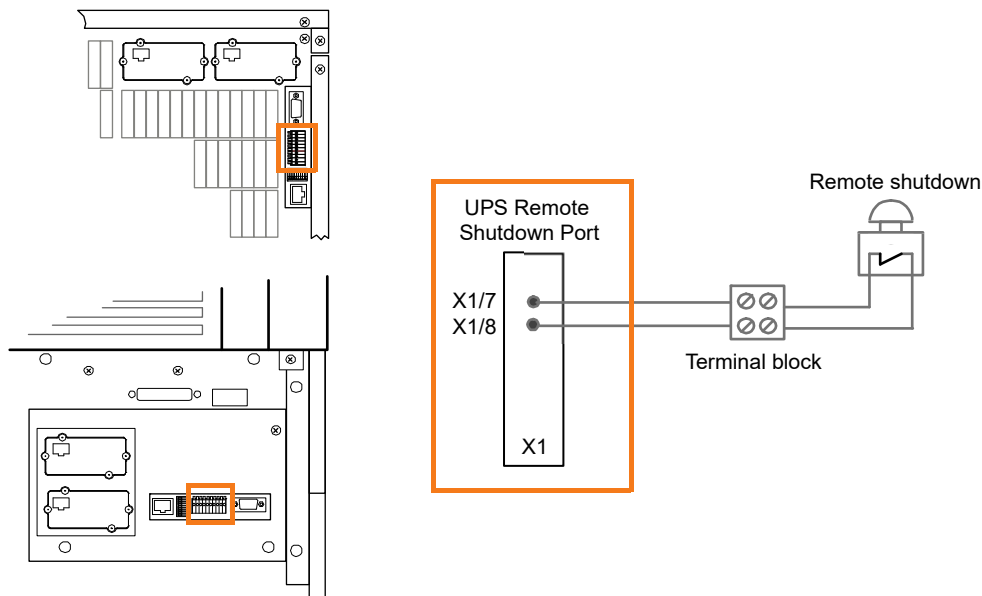

Figure 7.1 Remote Emergency Stop cabling

### 7.3 Generator ON facilities

The generator ON facility must use a normally-open contact which closes to indicate that a generator is running and supplying the UPS input power.

When used, this facility inhibits the operation of the battery charger and/or static bypass while the UPS is being supplied from a standby generator. See “Set-up User menu screen” in section 4.3.7.

1. Use a screened cable with 1 pair (section of wires 0.6 mm<sup>2</sup>) and maximum length of 100 m.
2. Connect the cable as shown in Figure 7.2.

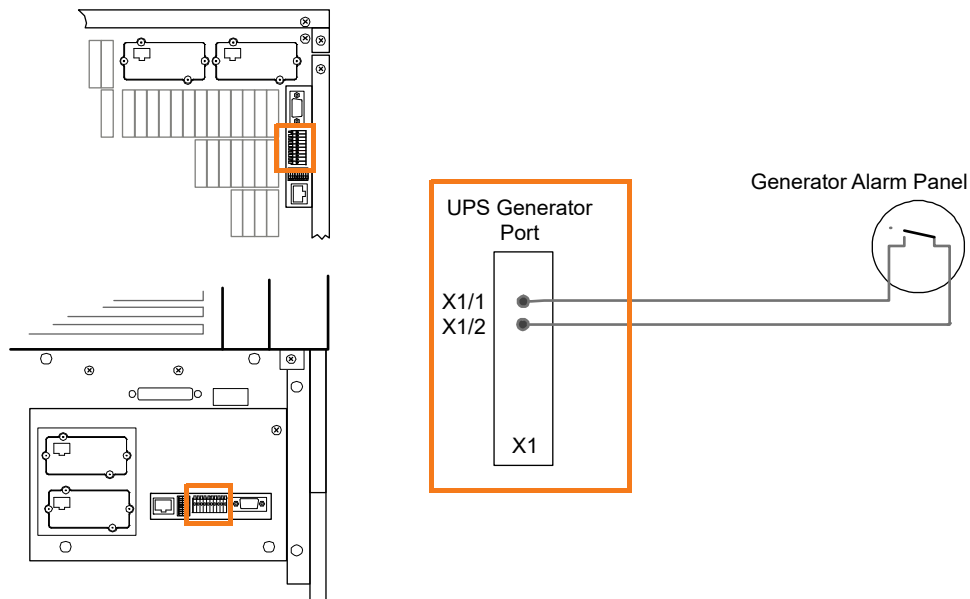

**Figure 7.2 Generator ON Connection**

## 7.4 Temperature sensor for temperature-dependant battery charging

A temperature sensor can be used to vary the battery charging voltage depending upon the battery temperature.

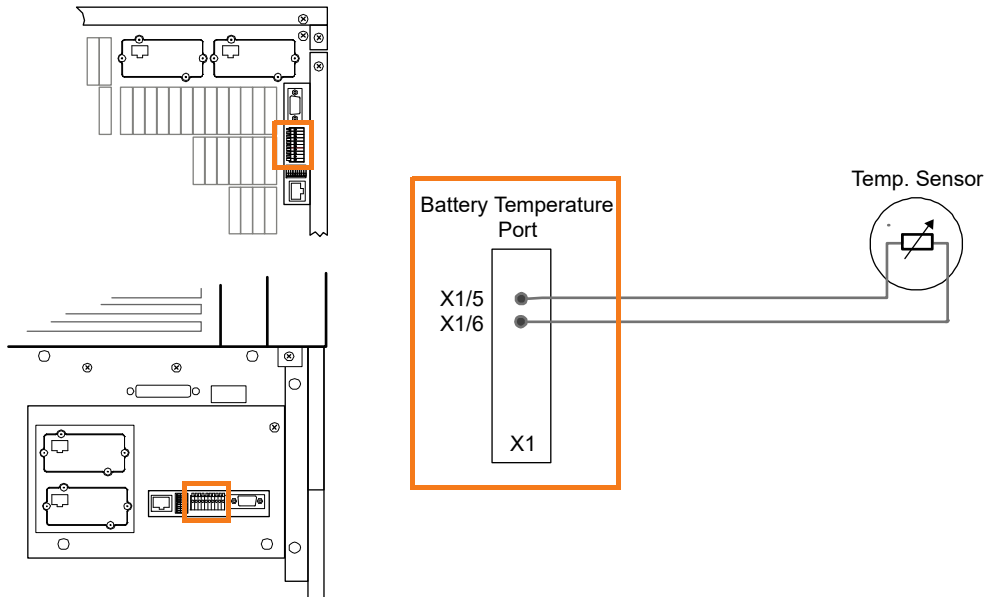

## 7.5 WAVEMON Shutdown and Management Software

### 7.5.1 Why is UPS Management important?

By combining a UPS with a variety of network management products, such as orderly shutdown software and SNMP adaptors, system-administrators can be assured that their electricity supplies are monitored for power disruptions and depleted battery conditions. Such conditions pose the greatest threat through power disturbance to valuable computer data by causing possible corruption or loss. By installing UPS/Mains monitoring software, administrators are able to monitor the utility power from a central location, allowing early warning of problems even across more complex systems like Wide Area Networks (WAN) and Enterprise Wide Networks of multinational companies.

A prolonged mains failure may outlast the battery autonomy of the UPS system. If this situation occurs the UPS management software will initiate an automatic, 'controlled' shutdown of the operating system, and so protect valuable data. Kohler Uninterruptible Power offer a wide range of local and remote monitoring and control systems, affording maximum protection for computer systems.

### 7.5.2 WAVEMON Shutdown and Monitoring Software

WAVEMON is an external monitoring and shutdown software application that is designed to operate with many of Kohler Uninterruptible Power UPS products. The package comprises a software installation CD suitable for most server operating systems, a standard cable set and a user manual

The WAVEMON system can monitor the dry port relay contacts available on terminal block X2, together with an RS232 port (JD11) – both located on the communications card.

When the WAVEMON system is used to monitor the X2 dry port contacts it is necessary to connect the X2 terminals of the UPS to the serial port of the server using a 0.5 mm<sup>2</sup> cable.

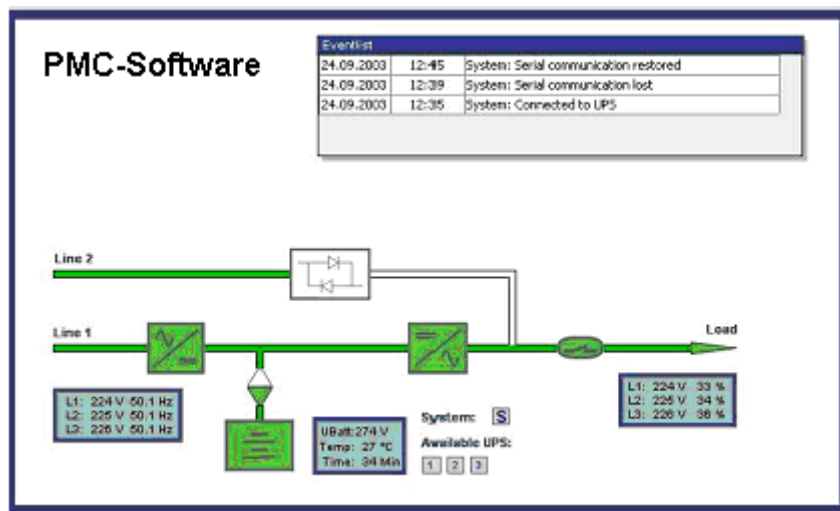

**Figure 7.3 Monitoring screen image.**

The main characteristics of WAVEMON software are (assuming RS232 port used):

- Automatic unattended master/slave shutdown in heterogeneous networks
- On-screen autonomy time/battery time countdown
- On-screen server log off and shutdown procedure
- Time and date stamp event log, extensive logging of all UPS activity and power quality data
- Scheduled UPS economy mode, service mode, other systems status
- Graphical user interface for Windows compatible platforms
- Automatic unattended local shutdown
- Special modules for the MS-Office software to close and save open documents
- Compatible with all optional modules like UPSDIALER, SNMP adaptors, temperature sensors, etc.

The UPS-Management software is a client-/server-application for networks and local workstations. Basically, the WAVEMON application consists of two parts: the server-module of the UPS-Management Software is *UPSServ*, which communicates via RS-232 cable with the UPS.

Working as a background process the *UPSServ* collects messages, received from the UPS, interprets the messages and then makes them available to the client-module *UPSCli* and to any SNMP-based management station.

When *UPSServ* detects voltage variations or a power failure it can execute various so called system 'event routines', which for example may shutdown the server or send a warning to connected users. These system event routines are a part of the UPS-Management Software can be adjusted to suit the customer's demands demands.

The UPS management software includes the licence for using the UPS service on one server with one UPS and an unlimited numbers of connected Windows workstations. When operating with two or more servers, a licence is required for every additional server, irrespective of whether the UPS service runs at that location, or if the server is halted by a UPS service via remote command.

The same regulations apply to the use of remote send/receive modules (RCCMD) and multi-server shutdown under NT, UNIX and other operating systems. The service programs are generally delivered as a single-licence. To use a single CD ROM to shutdown multiple servers you have to purchase additional CD license keys.

Parallel/redundant UPS systems are also manageable by the software. The main principle is to introduce a shutdown of a server only when strictly necessary. Correct parallel handling has therefore to manage a parallel system as a whole and always consider the system redundancy. The following statements apply:

- Every alarm on any unit is immediately notified, but a reaction to a serious fault is introduced only when the minimum number of UPS Modules necessary to supply the load exhibits an alarm situation.
- The real battery autonomy time of the (whole) parallel system is computed continuously.
- Maintenance on a redundant unit may be executed without affecting the management system (supervisor).

The Kohler PW 5000/TP can be integrated in a network in two ways:

1. By means of the server which is being powered by the UPS and is integrated in the network. In most of the cases the server is used as sub-agent and you only need the PMC-Software without any SNMP Adapter. You need a standard serial connection between the RS232 JD1 port of the UPS and the RS232 port of the computer/server.
2. In some situations it is preferable to interface the network via an SNMP adapter. By this way up to 50 computers can be shut down in a RCCMD environment. RCCMD (Remote Console Command) is an additional software module, which can be triggered by the SNMP device to executes a command (typically a shutdown command) on a remote system.

## 7.6 SNMP CARD/ADAPTOR For Network Management/Remote Monitoring

The Simple Network Management Protocol (SNMP) is a world-wide standardised communication-protocol. It is used to monitor any device in the network via simple control language. The UPS-Management Software also provides its data in this SNMP format with its internal software agent. The operating system you are using must be SNMP compatible. We offer our software with SNMP functionality together with NetWare, OS/2, all Windows NT systems on INTEL and ALPHA.

There are two types of SNMP-Adaptors available: External SNMP-Adaptor and Internal SNMP-Card (both have the same functions). Both can manage a parallel system (N modules) and return either global values – which are consistent for the whole parallel system – or specific values from the individual modules.

The SNMP adaptor requires a PC with terminal connections. For normal operation at least one network connection (Ethernet) is also required.

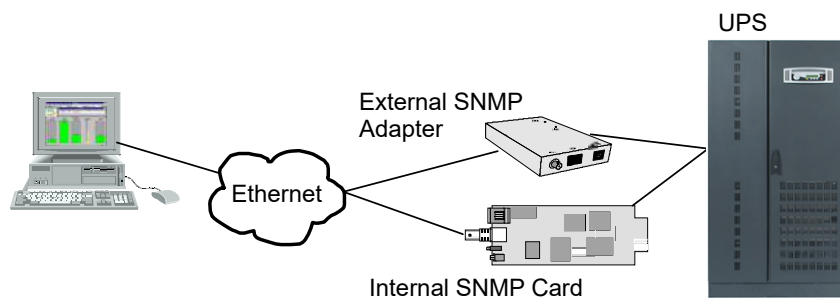

Figure 7.4 SNMP Adapter

### External SNMP Adapter

1. The small (125x70 mm) External SNMP adapter comes with following interfaces:
  - RJ-45 connector for 10/100 Base-T (auto switchable).
  - Serial Port for configuration (COM2) or optional ModBus interface.
  - Error/Link LED for UPS status.
  - Aux. Port.
  - DIP Switch.
  - Serial Port to the UPS (COM1)
  - DC Supply (9 VDC or 9-36 VDC supply, depending on model), from a UPS-backed socket.



**Internal SNMP Adapter**

The Internal SNMP-Card can be inserted into an appropriate extension slot of the PMC. This adapter communicates via the serial port of the UPS and makes a direct multiple server shut down possible without additional SNMP management software.

The SNMP adaptor is used to monitor any device in the network and can be used, utilising the RCCMD send function, for an automatic network wide shut down or informing connected users. The shut down procedure can be initiated from the remaining time (downtime) or as countdown timer from the beginning of the alarm. A shut down is therefore possible without extra input from the operator, but fully software controlled.

For detailed information please refer to the Software Manual provided with the WAVEMON CD ROM. This adaptor communicates via the serial port of the UPS and makes a direct multiple server shut down possible without additional SNMP management software.

**RCCMD - Remote Console Command module** for a multi-server shutdown. The RCCMD modules are independent programs that may be activated on the computer that is running UPSMAN. This makes a shutdown call possible in any LAN and WAN, regardless of the network type or operating system.



# 8

# Specifications

## 8.1 Mechanical

### Cabinet A

|   |    | Module Rating (kVA) |     |     |
|---|----|---------------------|-----|-----|
|   |    | 10                  | 15  | 20  |
| WITHOUT BATTERY ENCLOSURE<br>Dimensions (WxHxD) | mm | 345 x 720 x 710     |     |     |
| Weight (without battery)                        | kg | 60                  | 62  | 64  |
| Weight (with 48x7Ah battery)                    | kg | 180                 | 182 | 184 |
| Weight (with standard packaging)                | kg | +4                  |     |     |
| Colour  |    | Black (RAL 9005)    |     |     |

### Cabinet B

|   |    | Module Rating (kVA) |     |     |     |
|---|----|---------------------|-----|-----|-----|
|   |    | 10                  | 15  | 20  | 25  |
| WITHOUT BATTERY ENCLOSURE<br>Dimensions (WxHxD) | mm | 345 x 1045 x 710    |     |     |     |
| Weight (without battery)                        | kg | 88                  | 90  | 92  | 94  |
| Weight (with 96x7Ah battery)                    | kg | 328                 | 330 | 332 | 334 |
| Weight (with standard packaging)                | kg | +5                  |     |     |     |
| Colour  |    | Black (RAL 9005)    |     |     |     |

### Cabinet C

|   |    | Module Rating (kVA)   |                       |                       |                       |
|---|----|-----------------------|-----------------------|-----------------------|-----------------------|
|   |    | 25                    | 30                    | 40                    | 50                    |
| WITHOUT BATTERY ENCLOSURE<br>Dimensions (WxHxD) | mm | 440 x 1420 x 910      |                       |                       |                       |
| Weight (without battery)                        | kg | (9Ah/28Ah)<br>151/135 | (9Ah/28Ah)<br>160/145 | (9Ah/28Ah)<br>165/150 | (9Ah/28Ah)<br>170/155 |
| Weight (with 144x7/9Ah battery)                 | kg | 540                   | 550                   | 555                   | 560                   |
| Weight (with 48x28Ah battery)                   | kg | 605                   | 615                   | 620                   | 625                   |
| Weight (with standard packaging)                | kg | +5                    |                       |                       |                       |
| Colour  |    | Black (RAL 9005)      |                       |                       |                       |

## 8.2 Input Characteristics

|   |    | Module Rating (kVA)   |      |      |      |      |      |      |
|---|----|---|------|------|------|------|------|------|
|   |    | 10  | 15   | 20   | 25   | 30   | 40   | 50   |
| Nominal Input Voltage   | V  | 3x380/220V+N, 3x400V/230V+N, 3x415/240V+N   |      |      |      |      |      |      |
| Input Voltage Tolerance<br>(ref to 3x400/230V) for Loads in %:                      | V  | (-23%/+15%) 3x308/177 V to 3x460/264 V for <100% load<br>(-30%/+15%) 3x280/161 V to 3x460/264 V for < 80% load<br>(-40%/+15%) 3x240/138 V to 3x460/264 V for < 60% load |      |      |      |      |      |      |
| Input Frequency   | Hz | 35 - 70   |      |      |      |      |      |      |
| Input Power Factor  |    | PF=0.99 @ 100% load   |      |      |      |      |      |      |
| Inrush Current  | A  | max. In   |      |      |      |      |      |      |
| Input Distortion THDi   |    | Sine-wave THDi = 3.0% @ 100% load   |      |      |      |      |      |      |
| Max. Input Power with rated output power and charged battery (output pf = 0.9)      | kW | 9.6   | 14.4 | 19.1 | 23.9 | 28.7 | 38.3 | 47.9 |
| Max. Input Current with rated output power and charged battery (output pf = 0.9)    | A  | 13.9  | 20.8 | 27.8 | 34.7 | 41.6 | 55.5 | 69.4 |
| Max. Input Power with rated output power and discharged battery (output pf = 0.9)   | kW | 10.5  | 15.7 | 21   | 26.2 | 31.4 | 41.9 | 52.4 |
| Max. Input Current with rated output power and discharged battery (output pf = 0.9) | A  | 15.2  | 22.8 | 30.4 | 37.9 | 45.5 | 60.7 | 75.9 |

## 8.3 Output Characteristics

|   |      | Module Rating (kVA)  |      |      |      |      |      |      |
|---|------|--|------|------|------|------|------|------|
|   |      | 10   | 15   | 20   | 25   | 30   | 40   | 50   |
| Output Rated Power  | KW   | 9  | 13.5 | 18   | 22.5 | 27   | 36   | 45   |
| Output Current In @ p.f. 0.9 (400 V)                                  | A    | 14.4   | 21.7 | 28.9 | 36.1 | 43.3 | 57.7 | 72.2 |
| Output Current In @ p.f. 1.0 (400 V)                                  | A    | 13.0   | 19.5 | 26.0 | 32.5 | 39.0 | 52.0 | 65.0 |
| Output Rated Voltage  | V    | 3x380/220V or 3x400/230V or 3x415/240V   |      |      |      |      |      |      |
| Output Voltage Stability  | %    | Static: < ±1%<br>Dynamic (Step load 0%-100% or 100%-0%) < ±4%  |      |      |      |      |      |      |
| Output Voltage Distortion   | %    | With Linear Load < 2%<br>With Non-linear Load (EN62040-3:2001) < 4%  |      |      |      |      |      |      |
| Output Frequency  | Hz   | 50 Hz or 60 Hz   |      |      |      |      |      |      |
| Output Frequency Tolerance  | Deg. | Synchronized with mains < ±2%<br>(selectable for bypass operation) or < ±4% Free running ±0.1%                                 |      |      |      |      |      |      |
| Bypass operation  |      | At Nominal Input voltage of 3x400 V ±15%, or 196 V to 264 V ph-N   |      |      |      |      |      |      |
| Permissible Unbalanced Load<br>(All 3 phases regulated independently) | %    | 100%   |      |      |      |      |      |      |
| Phase Angle Tolerance<br>(With 100% Unbalanced load)                  | Deg. | ±0 deg.  |      |      |      |      |      |      |
| Overload Capability on Inverter                                       | %    | At p.f. 0.9 110% load 10 min.<br>At p.f. 0.9 130% load 1 min.<br>At p.f. 0.8 125% load 10 min.<br>At p.f. 0.8 150% load 1 min. |      |      |      |      |      |      |
| Output short capability (RMS)   | A    | Inverter: up to 3 x In during 40 ms<br>Bypass: 10 x In during 10 ms  |      |      |      |      |      |      |
| Crest - Factor  |      | 3: 1   |      |      |      |      |      |      |

### 8.4 Battery Characteristics

|  | Module Rating (kVA)                     |   |        |   |        |   |        |   |        |        |        |
|--|---|---|--------|---|--------|---|--------|---|--------|--------|--------|
|  | 10                                      |   | 15     |   | 20     |   | 25     |   | 30     | 40     | 50     |
| Cabinet Type   | A                                       | B | A      | B | A      | B | B      | C | C      | C      | C      |
| Min/Max Number of 12V Battery Blocks per string  | 22-50*                                  |   | 32-50* |   | 32-50* |   | 40-50* |   | 24-50* | 32-50* | 40-50* |
| Maximum Battery Charger Current (Amps)   | 4A                                      |   |        |   |        |   | 6A     |   |        |        |        |
| Battery Charging Curve   | Ripple free; IU (DIN 41773)             |   |        |   |        |   |        |   |        |        |        |
| Temperature compensation ready   | Standard (temp. sensor optional)        |   |        |   |        |   |        |   |        |        |        |
| Battery Test   | Automatic and periodically (adjustable) |   |        |   |        |   |        |   |        |        |        |
| Battery Type   | Maintenance free VRLA or NiCd           |   |        |   |        |   |        |   |        |        |        |
| * Depending on the effective load in kW used by the system (numbers shown are for 0.8 - 0.9 pf only) |   |   |        |   |        |   |        |   |        |        |        |

### 8.5 Environmental

|   |                                 | Module Rating (kVA)   |       |       |       |                            |       |       |  |  |
|---|---------------------------------|---|-------|-------|-------|----------------------------|-------|-------|--|--|
|   |                                 | 10  | 15    | 20    | 25    | 30                         | 40    | 50    |  |  |
| Audible Noise with 100% / 50% Load  | dBA                             | 55/49   | 55/49 | 57/49 | 57/49 | 58/50                      | 59/50 | 59/50 |  |  |
| Operation temperature   | °C                              | 0 - 40  |       |       |       |                            |       |       |  |  |
| Temperature for Batteries (recommended)   | °C                              | 20  |       |       |       |                            |       |       |  |  |
| Storage Temperature   | °C                              | Between -25 and +70   |       |       |       |                            |       |       |  |  |
| Battery Storage Time  |                                 | Max. 6 months   |       |       |       |                            |       |       |  |  |
| Max. altitude (above sea level)   | m                               | 1000m (3300ft) without de-rating  |       |       |       |                            |       |       |  |  |
| De-rating factor for use at altitudes above 1000m sea level according (IEC 62040-3) | ALL MODULES                     |   |       |       |       |                            |       |       |  |  |
|   | Metres above sea level (m / ft) |   |       |       |       | De-Rating Factor for Power |       |       |  |  |
|   | 1500 / 4850                     |   |       |       |       | 0.95                       |       |       |  |  |
|   | 2000 / 6600                     |   |       |       |       | 0.91                       |       |       |  |  |
|   | 2500 / 8250                     |   |       |       |       | 0.86                       |       |       |  |  |
| 3000 / 9900   |                                 |   |       |       | 0.82  |                            |       |       |  |  |
| Relative Air-humidity   |                                 | Max. 95% (non-condensing)   |       |       |       |                            |       |       |  |  |
| Positional Clearances   |                                 | <b>Front:</b> A minimum of 900mm should be allowed for free passage.<br><b>Side:</b> 600mm left and right side access is required for service.<br><b>Rear:</b> A minimum of 200mm is required for cooling air circulation and the unit should be cabled such that it can be pulled forward to allow 600mm rear clearance for service/maintenance. |       |       |       |                            |       |       |  |  |
| Accessibility (Operator)  |                                 | 10kVA – 25kVA in type A or B cabinets require front/rear access<br>25kVA – 40kVA in type C cabinets require front access only   |       |       |       |                            |       |       |  |  |
| Input and Output Power Cabling  |                                 | 10kVA – 25kVA in type A or B cabinets are cabled at the rear<br>25kVA – 40kVA in type C cabinets are cabled at the rear   |       |       |       |                            |       |       |  |  |
| Efficiency AC-AC up to (at pf=1.0) (depending on UPS power)                         | Load:                           | 100%  | 75%   | 50%   | 25%   |                            |       |       |  |  |
|   | Efficiency:                     | 95.5%   | 95.5% | 95%   | 94.5% |                            |       |       |  |  |
| Eco-Mode efficiency at 100% load  | %                               | 98%   |       |       |       |                            |       |       |  |  |

## 8.6 Heat Dissipation With Non-Linear Loads

|  |       | 10kVA | 15kVA | 20kVA | 25kVA | 30kVA | 40kVA | 50kVA |
|--|-------|-------|-------|-------|-------|-------|-------|-------|
| Heat Dissipation with 100% Non-linear Load per range (EN 62040-3)      | W     | 600   | 900   | 1100  | 1400  | 1700  | 2300  | 2900  |
| Heat Dissipation with 100% Non-linear Load per range (EN 62040-3)      | BTU/h | 2048  | 3072  | 3754  | 4778  | 5802  | 7850  | 9898  |
| Airflow (25°C - 30°C) with 100% Non-linear Load per range (EN 62040-3) | m³/h  | 150   | 150   | 150   | 150   | 570   | 570   | 570   |
| Heat Dissipation without load  | W     | 120   | 150   | 150   | 170   | 250   | 300   | 350   |

## 8.7 Standards

|  | Module Rating (kVA)  |    |    |    |    |    |    |
|--|--|----|----|----|----|----|----|
|  | 10   | 15 | 20 | 25 | 30 | 40 | 50 |
| Safety   | IEC/EN 62040-1-1:2003, IEC/EN 60950-1:2001/A11:2004              |    |    |    |    |    |    |
| Electromagnetic Compatibility  | IEC/EN 62040-2:2005, IEC/EN61000-3-2:2000, IEC/EN61000-6-2:2001, |    |    |    |    |    |    |
| EMC Classes<br>C2 domestic or industrial In < 16A<br>C3 industrial In >16A | C2   | C3 |    |    |    |    |    |
| Performance  | IEC/EN62040-3:2001   |    |    |    |    |    |    |
| Product certification  | CE   |    |    |    |    |    |    |
| Degree of protection   | IP 20  |    |    |    |    |    |    |

## 8.8 Communication Options

|  | All Modules   |
|--|---|
| Power Management Display (PMD)   | LCD display   |
| RS232 on Sub-D9 port   | For monitoring and integration in network management  |
| Customer Interfaces: Inputs (DRY PORTS)                                | 1 Remote Shut down [EMERGENCY OFF (Normally closed)]<br>1 GEN-ON (Normally open)<br>1 Programmable Customer's Inputs (Normally open)<br>1 Temp. Sensor for Battery Control<br>1 12Vdc source (max. 250mA) |
| RJ45 port  | For multidrop purpose (optional)  |
| Relay card +USB Including:<br>Customer Interfaces: Outputs (DRY PORTS) | Common Alarm<br>Load on Bypass<br>Battery Low<br>Load on Inverter<br>Mains Failure  |
| RS232 on USB Port  | For remote signalling and automatic computer shutdown   |
| SNMP Card (slot already included)                                      | For monitoring and integration in network management  |

### 8.9 Fuses & Cables Quick Reference

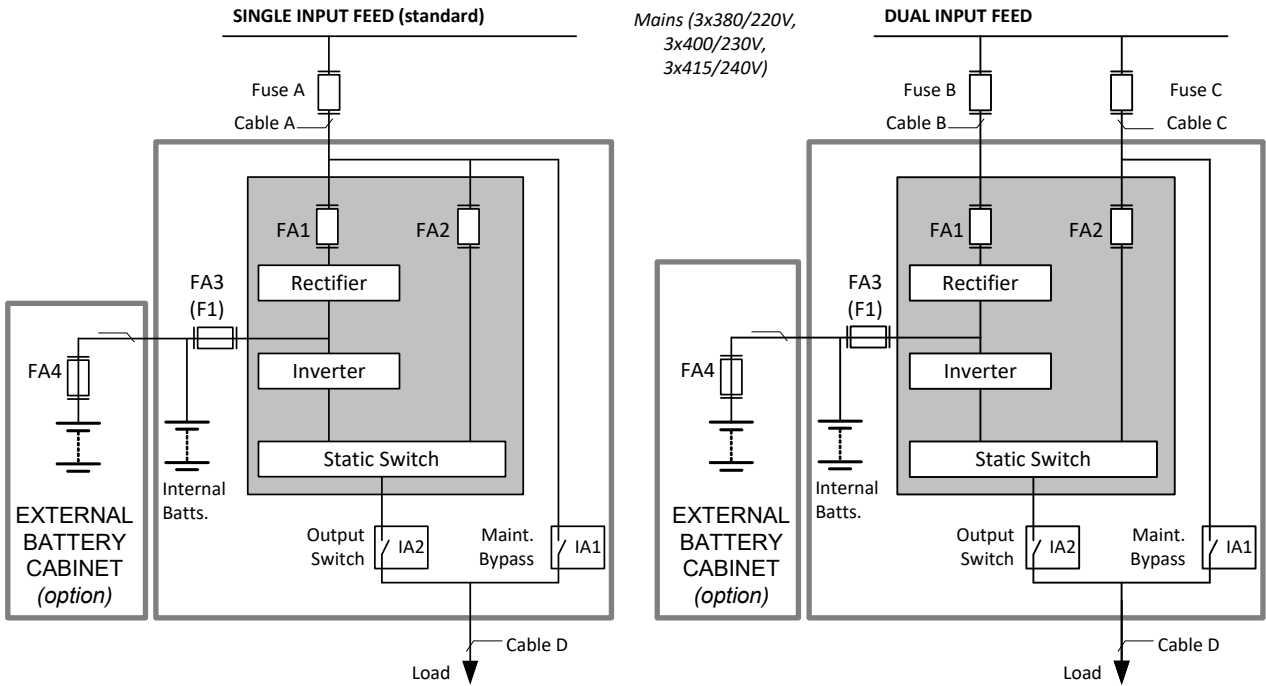

Mains (3x380/220V,  
3x400/230V,  
3x415/240V)

**SINGLE INPUT FEED**

| Power (kVA) | Fuse A (Agl/CB) (A) | Cable A (mm <sup>2</sup> ) | Cable D (mm <sup>2</sup> ) |
|-------------|---------------------|----------------------------|----------------------------|
| 10          | 3 x 20              | 5 x 2.5                    | 5 x 2.5                    |
| 15          | 3 x 32              | 5 x 4.0                    | 5 x 4.0                    |
| 20          | 3 x 40              | 5 x 6.0                    | 5 x 6.0                    |
| 25          | 3 x 40              | 5 x 6.0                    | 5 x 6.0                    |
| 30          | 3 x 63              | 5 x 10                     | 5 x 10                     |
| 40          | 3 x 80              | 5 x 25                     | 5 x 25                     |
| 50          | 3 x 80              | 5 x 25                     | 5 x 25                     |

**DUAL INPUT FEED**

| Power (kVA) | Fuse B (Agl/CB)(A) | Cable B (mm <sup>2</sup> ) | Fuse C (Agl/CB)(A) | Cable C (mm <sup>2</sup> ) | Cable D (mm <sup>2</sup> ) |
|-------------|--------------------|----------------------------|--------------------|----------------------------|----------------------------|
| 10          | 3 x 20             | 5 x 2.5                    | 3 x 20             | 5 x 2.5                    | 5 x 2.5                    |
| 15          | 3 x 32             | 5 x 4.0                    | 3 x 32             | 5 x 4.0                    | 5 x 4.0                    |
| 20          | 3 x 40             | 5 x 6.0                    | 3 x 40             | 5 x 6.0                    | 5 x 6.0                    |
| 25          | 3 x 40             | 5 x 6.0                    | 3 x 40             | 5 x 6.0                    | 5 x 6.0                    |
| 30          | 3 x 63             | 5 x 10                     | 3 x 63             | 5 x 10                     | 5 x 10                     |
| 40          | 3 x 80             | 5 x 25                     | 3 x 80             | 5 x 25                     | 5 x 25                     |
| 50          | 3 x 80             | 5 x 25                     | 3 x 80             | 5 x 25                     | 5 x 25                     |

1. Fuse and Cable recommendations to IEC 60950-1:2001
2. The fuse and cable rating details in the above tables are a recommendation only.
3. The UPS must be installed to prescribed IEC or local regulations (e.g. BS7671).
4. External DC Cables and Battery fuses are bespoke to the installation.